

Water Pressure Reducing Valves

Series LF25AUB-Z3

Water Pressure Reducing Valves**

Sizes: 1/2" – 2" (15 – 50mm)

LEAD FREE Series LF25AUB-Z3 Water Pressure Reducing Valves are designed to reduce incoming water pressure to a sensible level to protect plumbing system components and reduce water consumption. This series is suitable for water supply pressures up to 300psi (20.7 bar) and may be adjusted from 25 – 75psi (172 – 517 kPa). The LF25AUB-Z3 features Lead Free* construction to comply with Lead Free* installation requirements. The standard setting is 50psi (345 kPa). All parts are quickly and easily serviceable without removing the valve from the line. The standard bypass feature*** permits the flow of water back through the valve into the main when pressures, due to thermal expansion on the outlet side of the valve, exceed the pressure in the main supply.



LF25AUBZ3

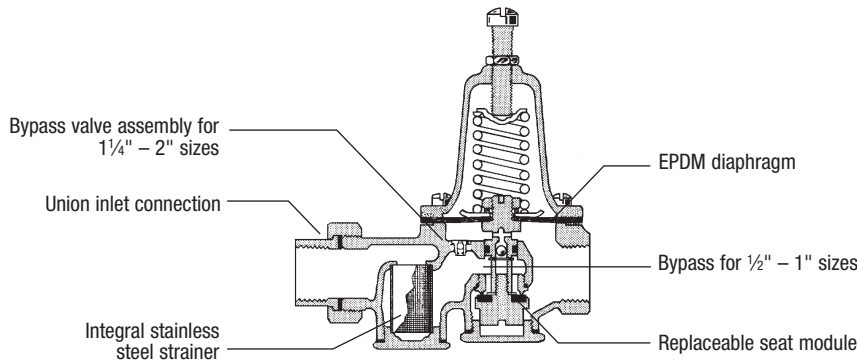

Features

- Standard construction includes Z3 sealed spring cage and stainless steel corrosion resistant adjusting & cage screws for accessible outdoor or pit installations
- Union inlet connection
- Integral stainless steel strainer
- Replaceable seat module
- Lead Free* cast copper silicon alloy construction
- Serviceable in line
- Bypass feature controls thermal expansion pressure***
- High temperature resistant reinforced diaphragm for hot water

Models

- LF25AUB-Z3** NPT threaded female union inlet x NPT female outlet
- LF25AUB-S-Z3** Solder union inlet x NPT female outlet
- LF25AUB-DU-Z3** Double Union – NPT threaded union female inlet and outlet
- LF25AUB-S-DU-Z3** Double Union – Solder union inlet and outlet
- LF25AUB-DU-THDxPEX-Z3** Double Union – NPT threaded female inlet and PEX union outlet
- LF25AUB-DU-LF-Z3** Double union body less fittings (3/4", 1", 1 1/4")
- LF25AUB-QC-Z3** Single Union – Quick-Connect union inlet (1/2", 3/4", 1")
- LF25AUB-DU-QC-Z3** Double Union – Quick-Connect inlet and outlet (1/2", 3/4", 1")

Options

add Suffix:

- GG** - Gauge tapping, 1/8" (3mm)
- GG** - Gauge tapping and 160psi (11 bar) gauge
- HP†** - High pressure range 75–125psi (5.2 – 8.6 bar)
- LP†** - Low pressure range 10–35psi (69 – 241 kPa)
- Z7** - 400psi (27.6 bar) initial pressure, 1/2" (20mm) models only

Pressure – Temperature

Temperature Range: 33°F – 160°F
(0.5°C – 71°C)

Maximum Working Pressure: 300psi
(20.7 bar)

Adjustable Reduced Pressure Range:
25–75psi (172 – 517 kPa)

Standard Reduced Pressure Setting:
50psi (345 kPa)

Standards



Meets requirements of ASSE Standard 1003; ANSI A112.26.2; CSA Standard B356; Southern Standard Plumbing Code and listed by IAPMO.
Military Standard MIL-V-18146B Type I.

*The wetted surface of this product contacted by consumable water contains less than 0.25% of lead by weight.

**A water saving test program concluded that reducing the supply pressure from 80-50psi (551-345 kPa) resulted in a water savings of 30%.

***The bypass feature will not prevent the pressure relief valve from opening on the hot water supply system with pressure above 150psi (10.3 bar).

†Currently not available with G or GG options.

Water Pressure Reducing Valves

Capacity

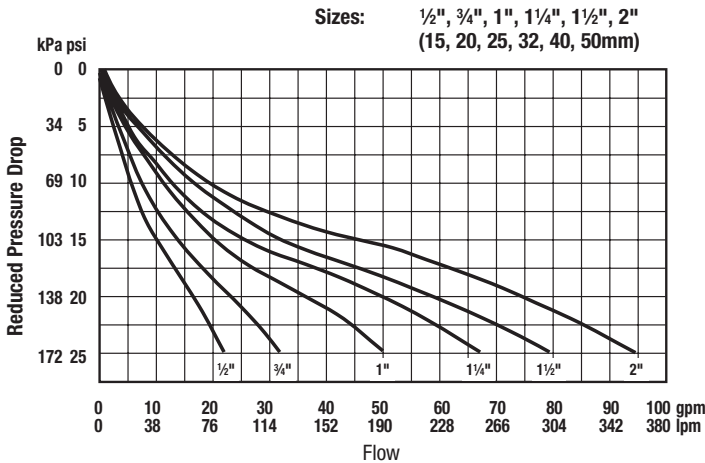

Dimensions — Weights

- A - LF25AUB-Z3
- A1 - LF25AUB-S-Z3
- A2 - LF25AUB-DU-LF-Z3
- B - LF25AUB-DU-Z3
- B1 - LF25AUB-S-DU-Z3
- B2 - LF25AUB-DU-THDxPEX-Z3
- ET - NPT Engagement for tight joint
- ES - Female sweat socket depth
- EP - PEX end connection
- FQC - Quick-Connect union

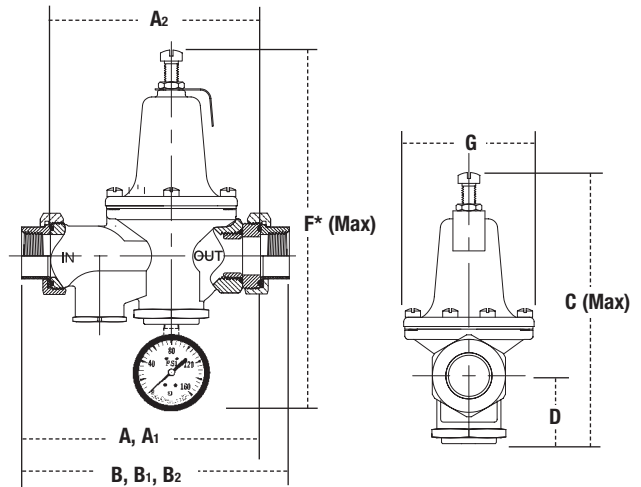
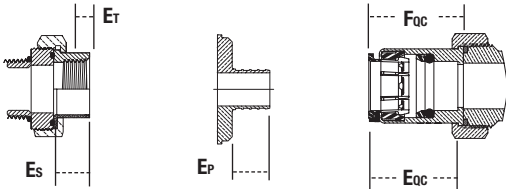

SIZE (DN)		DIMENSIONS													
		A		A ₁		A ₂		B		B ₁		B ₂		C	
in.	mm	in.	mm	in.	mm	in.	mm	in.	mm	in.	mm	in.	mm	in.	mm
1/2	15	5 3/8	137	5 5/16	135	5 3/16	132	6 7/16	164	6 3/8	162	—	—	7	178
3/4	20	5 5/16	135	5 1/2	140	5 1/4	133	6 1/2	165	6 7/8	175	6 3/4	171	7	178
1	25	6	152	6 1/4	159	5 7/8	149	7 3/8	187	7 13/16	198	7 11/16	195	8	203
1 1/4	32	8 3/4	222	8 15/16	227	8 1/4	210	10 3/4	273	11	279	—	—	9	229
1 1/2	40	8 3/4	222	9	229	8 1/4	210	10 3/4	273	11 3/16	284	—	—	9 1/2	241
2	50	9 1/4	235	10	254	8 3/4	222	11 5/16	287	12 11/16	322	—	—	11 1/4	286

SIZE (DN)		DIMENSIONS										WEIGHT			
D		F*		G		E _T		E _S		E _P		F _{OC}		lbs.	kgs.
in.	mm	in.	mm	in.	mm	in.	mm	in.	mm	in.	mm	in.	mm		
1 1/2	38	9 7/16	240	3 3/8	79	1/2	13	1/2	13	—	—	1 1/2	38	3.5	1.6
1 1/2	38	9 7/16	240	3 3/8	79	1/2	13	3/4	19	5/8	16	1 11/16	42	3.5	1.6
1 3/4	44	10 7/16	266	3 3/8	92	5/8	16	15/16	23	13/16	21	1 3/4	45	6.5	3.0
2 1/8	54	11 7/16	291	3 3/8	92	5/8	16	1	25	—	—	—	—	10	4.5
2 3/8	60	11 15/16	304	4 1/16	103	5/8	16	1 1/16	28	—	—	—	—	10	4.5
3 1/4	83	13 11/16	348	4 3/4	121	5/8	16	1 5/16	34	—	—	—	—	15	6.8

* Dimension includes optional gauge

For additional information, reference literature ES-LF25AUB.