

CONTRACTOR	
PROJECT	DATE
PREPARED BY	MODEL : WI UPC

EG – Electro-Galvanized. Electroplating deposits zinc on the surface of the steel by electrolysis from a bath of zinc salts. Recommended for relatively dry indoor use. This is the standard coating for most Phoenix products. Thickness of applied zinc is between 0.2 mils to 0.5 mils [5.1 µm to 12.7 µm]. Coatings on Centaur EG products meet ASTM B633 SC1 Type III.

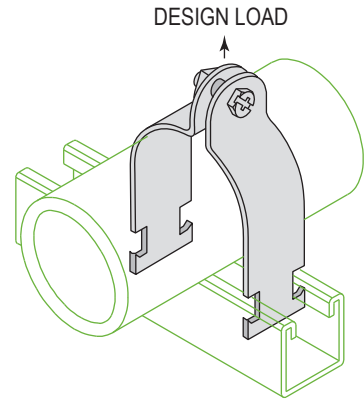

Catalog Number	Clamp Size		O.D.		Design Load		Wt. lbs
	in	mm	in	mm	lbs	kN	
WI UPC1/2	1/2	15	0.773	19.6	400	1.78	0.10
WI UPC3/4	3/4	20	0.986	25.0	600	2.67	0.13
WI UPC1	1	25	1.239	31.5	600	2.67	0.15
WI UPC1 1/2	1 1/2	40	1.820	45.7	800	3.56	0.29
WI UPC2	2	50	2.286	58.1	800	3.56	0.34

* These clamps are designed to fit both pipe (rigid conduit) and thin walled tubing (EMT) in the corresponding sizes.

APPLICATION AND PERFORMANCE SPECIFICATION INFORMATION IS SUBJECT TO CHANGE WITHOUT NOTIFICATION