



3 Inch Duct Series

Super Low Profile. Super Low Energy Consumption.

Weighing less than 5 lbs., the powerful and compact Delta BreezSlim sets the bar for performance in the popular small fan size of 7 1/2" x 7 1/4" x 4". Operating at just 1.0 sone, this quiet fan features Delta's super reliable brushless DC motor, an LED indicator light so you know it's running, and a modern grille design. Perfect for retrofit into an existing space or for ceiling mount or wall mount installation (UL listed for both) into your next multifamily or single-family project. BreezSlim breaks the mold of the everyday bathroom exhaust fan. Available in contractor packs.

Features:

Innovative brushless DC motor design for long life, low noise and low power consumption.

- Energy savings up to 85%¹ and 3" duct (standard)
- 1 sone – The quietest ever in a 7 1/2" x 7 1/4" bath fan
- Exceeds ENERGY STAR requirements by 217% in energy efficiency²
- UL listed for both ceiling-mount and wall-mount installation

1. Based upon SLM50 vs. market AC motor

2. Based upon ENERGY STAR v4.0 criteria for residential ventilating fans

	Delta Breez	Market AC Motor
Energy Use (Watts)	6.4	45.2
Noise Level (Sones)	1.0	4.0
Annual Energy Cost per Fan (24/7) ³	\$6.73	\$47.56

3. Calculations based upon U.S. average retail electricity. Actual results may vary



Available with Project Pack Components



Available with metal duct adapter

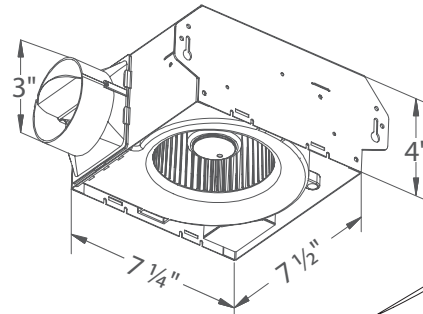

Fan Housing

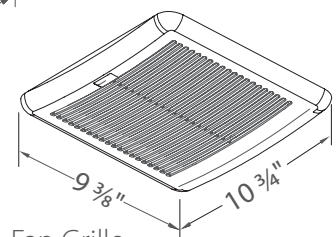

Fan Grille



LED Indicator Light: SLM50, SLM70



LED Indicator Light: SLM70D



LED Indicator Light: SLM70H



breez Slim

3 Inch Duct Series



SLM70ELED

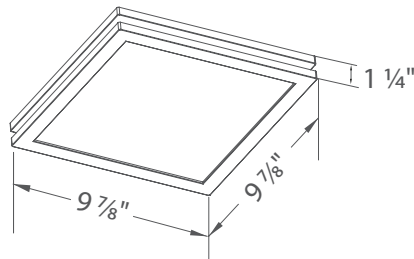

Specifications

SLM50* - 50 CFM Single Speed Exhaust Fan



3" Duct (Standard)		
Static Pressure (Inches w.g.)	0.1	0.25
Air Flow (CFM)	50	36
Sones	1.0	1.2
Power Consumption (Watts)	6.4	6.3
Energy Efficiency (CFM/Watts)	11.6	7.4
Current (Amps)	0.18 Max	
Power Rating (V/Hz)	120/60	
Project Pack Components Available SLM-A (housing) and SLM50-B (motor grille)		

SLM70 - 70 CFM Single Speed Exhaust Fan



3" Duct (Standard)		
Static Pressure (Inches w.g.)	0.1	0.25
Air Flow (CFM)	70	54
Sones	2.0	1.5
Power Consumption (Watts)	13.2	11.6
Energy Efficiency (CFM/Watts)	5.8	5.0
Current (Amps)	0.29 Max	
Power Rating (V/Hz)	120/60	
Project Pack Components Available SLM-A (housing) and SLM70-B (motor grille)		

* Product is ENERGY STAR Most Efficient 2023 distinction and ENERGY STAR qualified

SLM70H - 70 CFM Fan with Humidity sensor



3" Duct (Standard)		
Static Pressure (Inches w.g.)	0.1	0.25
Air Flow (CFM)	70	54
Sones	2.0	1.5
Power Consumption (Watts)	13.2	11.6
Energy Efficiency (CFM/Watts)	5.8	5.0
Current (Amps)	0.29 Max	
Power Rating (V/Hz)	120/60	
Project Pack Components Available SLM-A (housing) and SLM70H-B (motor grille)		

SLM70D - 70 CFM Fan with Dual Speed



	Continuous low speed		Full Speed	
	Static Pressure (Inches w.g.)	0.1	0.25	0.1
Air Flow (CFM)	40	25	70	50
Sones	0.8	1.0	2.0	1.5
Power Consumption (Watts)	5.0	6.0	13.2	11.6
Energy Efficiency (CFM/Watts)	12.9	6.3	7.1	6.2
Current (Amps)	0.29 Max			
Power Rating (V/Hz)	120/60			

SLM70ELED - 70 CFM Fan Edge-Lit Dimmable LED Light



3" Duct (Standard)		
Static Pressure (Inches w.g.)	0.1	0.25
Air Flow (CFM)	70	53
Sones	2.0	1.5
Power Consumption (Watts)	13.2	11.6
Energy Efficiency (CFM/Watts)	6.0	5.4
Current (Amps)	0.29 Max	
Power Rating (V/Hz)	120/60	
LED Light (Watts/Lumens)	13/850	

Delta BreezSignature SLM-DGL Designer Grille

The SLM-DGL designer fan grille is offered as an alternative to the standard grille on Delta Breez SLM50, SLM70, SLM70H, ITG50, ITG80, ITG70BT, ITG80H, and ITG100.

Features:

- Adds modern aesthetic to bathroom
- Made of long-lasting ABS material
- Paintable to coordinate with any style bathroom
- Size: 10 3/4" x 10 3/4"

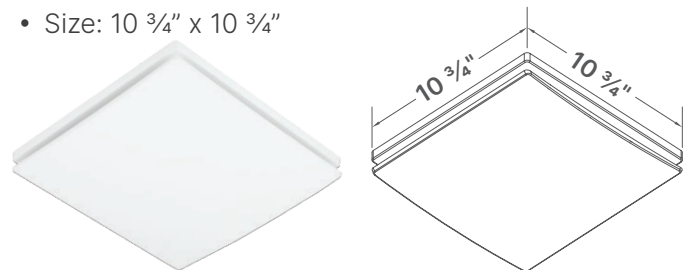

PRODUCT SELECTION GUIDE: FIND THE MOST SUITABLE FAN

	Model #	Air Flow (CFM)	Duct Size	Description	
GreenBuilder	GBR80	80	4 inches	Single Speed	
	GBR80H	80	4 inches	Fan with Humidity Sensor	
	GBR80HLED	80	4 inches	Fan/Dimmable LED Light with Humidity Sensor	
	GBR80LED	80	4 inches	Fan/Dimmable LED Light	
	GBR100	100	4 inches	Single Speed	
	GBR100H	100	4 inches	Fan with Humidity Sensor	
	GBR100LED	100	4 inches	Fan/Dimmable LED Light	
	GBR100LED-DECOR	100	4 inches	Fan/Dimmable LED Light Decor	
Slim	SLM50	50	3 inches	Single Speed	
	SLM70	70	3 inches	Single Speed	
	SLM70ELED	70	3 inches	Fan with Edge-Lit Dimmable LED Light	
	SLM70H	70	3 inches	Fan with Humidity Sensor	
	SLM70D	70	3 inches	Fan with Dual Speed	
	SLM80	80	4 inches Oval	Single Speed	
	SLM100	100	4 inches Oval	Single Speed	
	SLM50-110-C	50-110	4 inches Oval	High Speed Options Fan	
	SLM50-110LED-C	50-110	4 inches Oval	Fan/Dimmable LED Light	
	SLM80-110H-C	80-110	4 inches Oval	Fan with Humidity Sensor	
	SLM80-110-C	80-110	4 inches Oval	High Speed Options Fan	
	SLM80-110D-C	80-110	4 inches Oval	Fan with Dual Speed	
	SLM80-110LED-C	80-110	4 inches Oval	Fan/Dimmable LED Light	
	SLM80-110DLED-C	80-110	4 inches Oval	Fan/Dimmable LED Light with Dual Speed	
	SLM80-110	80-110	4 inches Oval	High Speed Options Fan	
	SLM80-110D	80-110	4 inches Oval	Fan with Dual Speed	
SLM80-110LED	80-110	4 inches Oval	Fan/Dimmable LED Light		
SLM80-110DLED	80-110	4 inches Oval	Fan/Dimmable LED Light with Dual Speed		
Integrity	ITG50	50	4 inches	Single Speed	
	ITG50LED	50	4 inches	Fan/Dimmable LED Light	
	ITG70BT	70	4 inches	Fan with Bluetooth®	
	ITG80	80	4 inches	Single Speed	
	ITG80H	80	4 inches	Fan with humidity Sensor	
	ITG80LED	80	4 inches	Fan/Dimmable LED Light	
	ITG80RLED-ADJ	80	4 inches	Fan/Dimmable LED Light, Round, Adjustable Color Temperature	
	ITG100	100	4 inches	Single Speed	
	ITG100ELED	100	4 inches	Fan/Edge-lit Dimmable LED Light	
	ITG100RLED	100	4 inches	Fan/Edge-Lit Dimmable LED Light, Flat Round Panel	
Radiance	RAD80	80	4 inches	Fan with Heater	
	RAD80L	80	4 inches	Fan/Light Combo with heater	
	RAD80LED	80	4 inches	Fan/Dimmable LED Light with Heater	
	RAD110LED	110	4 inches	Fan/Dimmable LED Light with Heater	
Professional	Pro300	300	6 inches	Single Speed	
Fresh	FRS200	30-200	6 inches	High Speed Inline Fan	

LED Light
 Dimmable LED Light
 Adjustable motion sensor
 Adjustable humidity sensor
 Adjustable dual speed