

REVISIONS				
REV	LTN	DESCRIPTION	DATE	APP'D
A		RLSD; ECO-10-012210	11JUN2010	GG RA
B		REV PER BNS_CD_BRAND	01FEB2017	GG DC

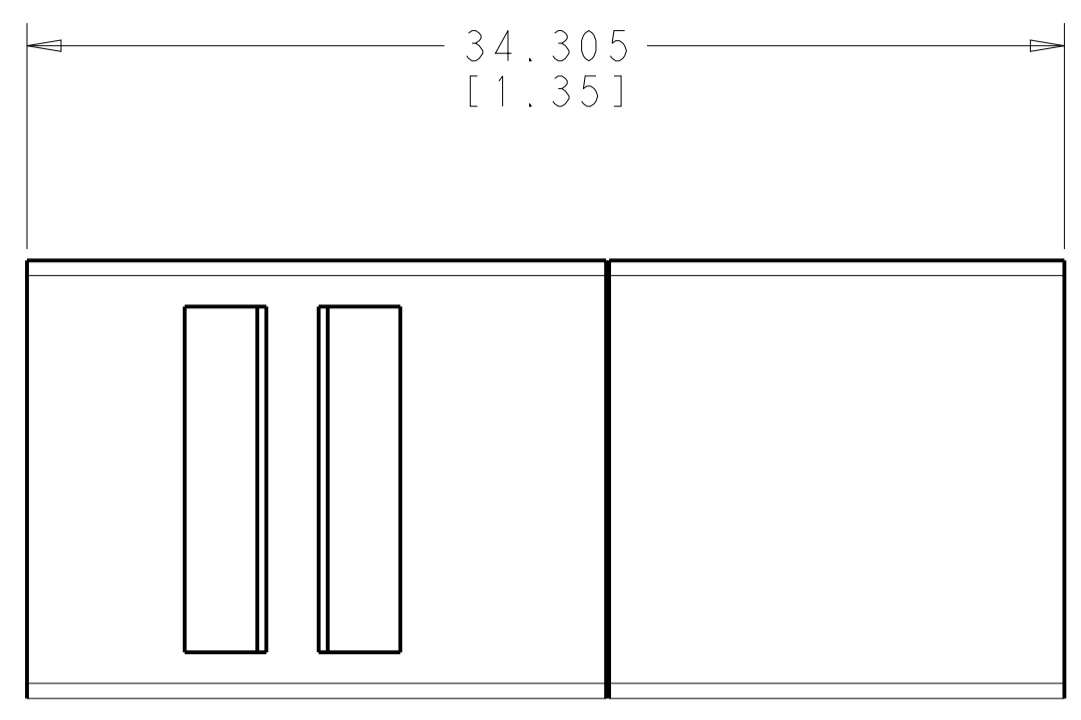

1 MATERIAL: ABS MOLDING COMPOUND.
UL94V-0 THERMOPLASTIC.

2 ALL DIMENSIONS SHOWN ARE NOMINAL.

3. ELECTRICAL:

- CONTACT CURRENT RATING: 0.5A MIN.
- VOLTAGE RATING: 40V AC(rms)
- INSULATION RESISTANCE: 100M OHMS MIN
- CONTACT RESISTANCE: 10M OHMS MAX
- DIELECTRIC WITHSTANDING VOLTAGE: 300V AC
- OPERATION TEMPERATURE: -55°C TO +85°C

4. MECHANICAL:

- INSERTION FORCE: 4.5KGF MAX
- WITHDRAW FORCE: 0.5KGF - 4KGF
- DURABILITY MATING CYCLE: 10,000 CYCLES MIN

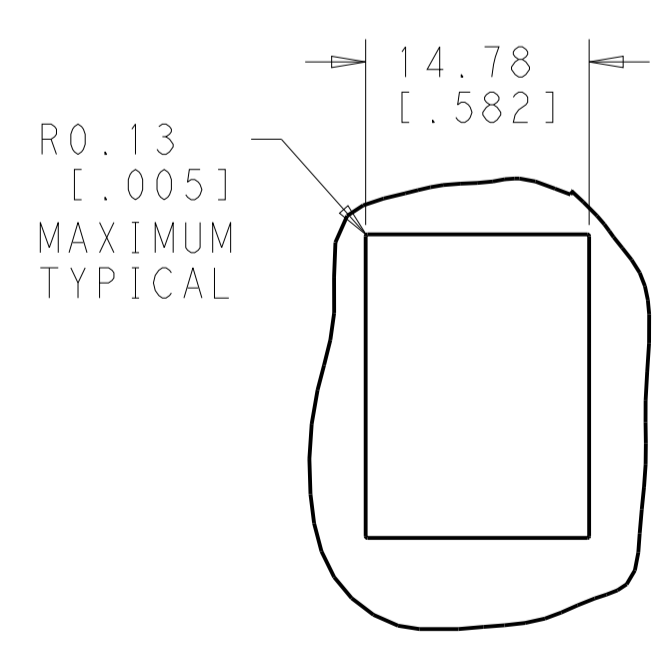
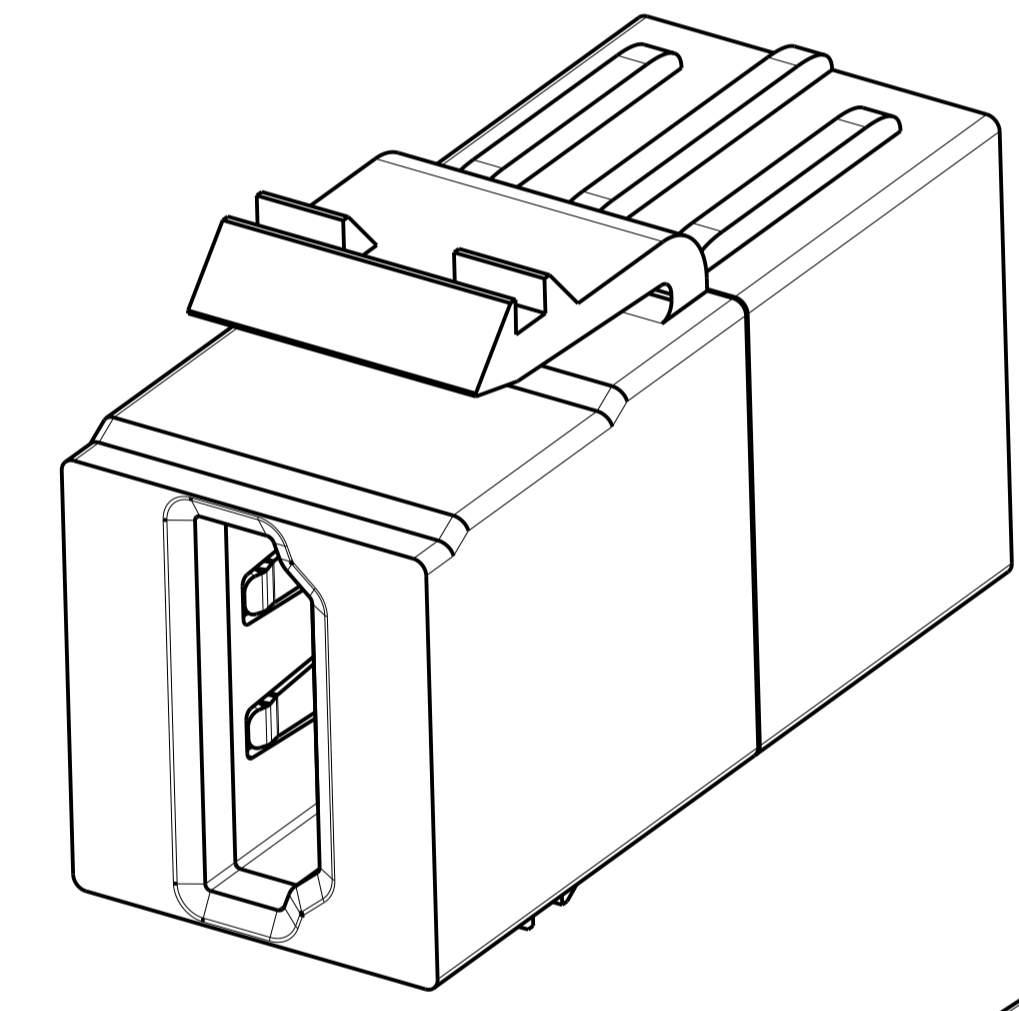
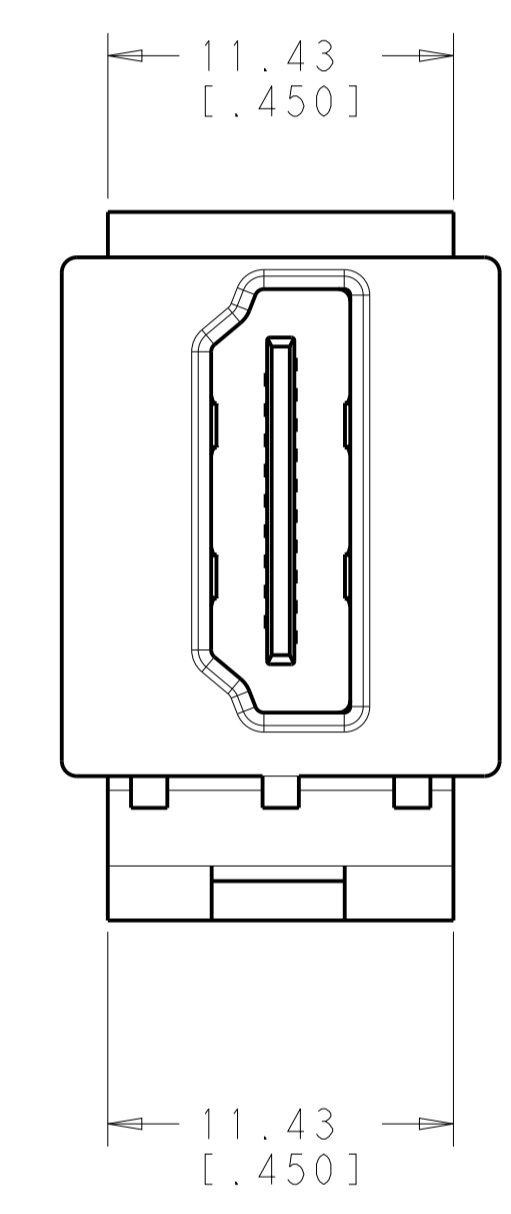
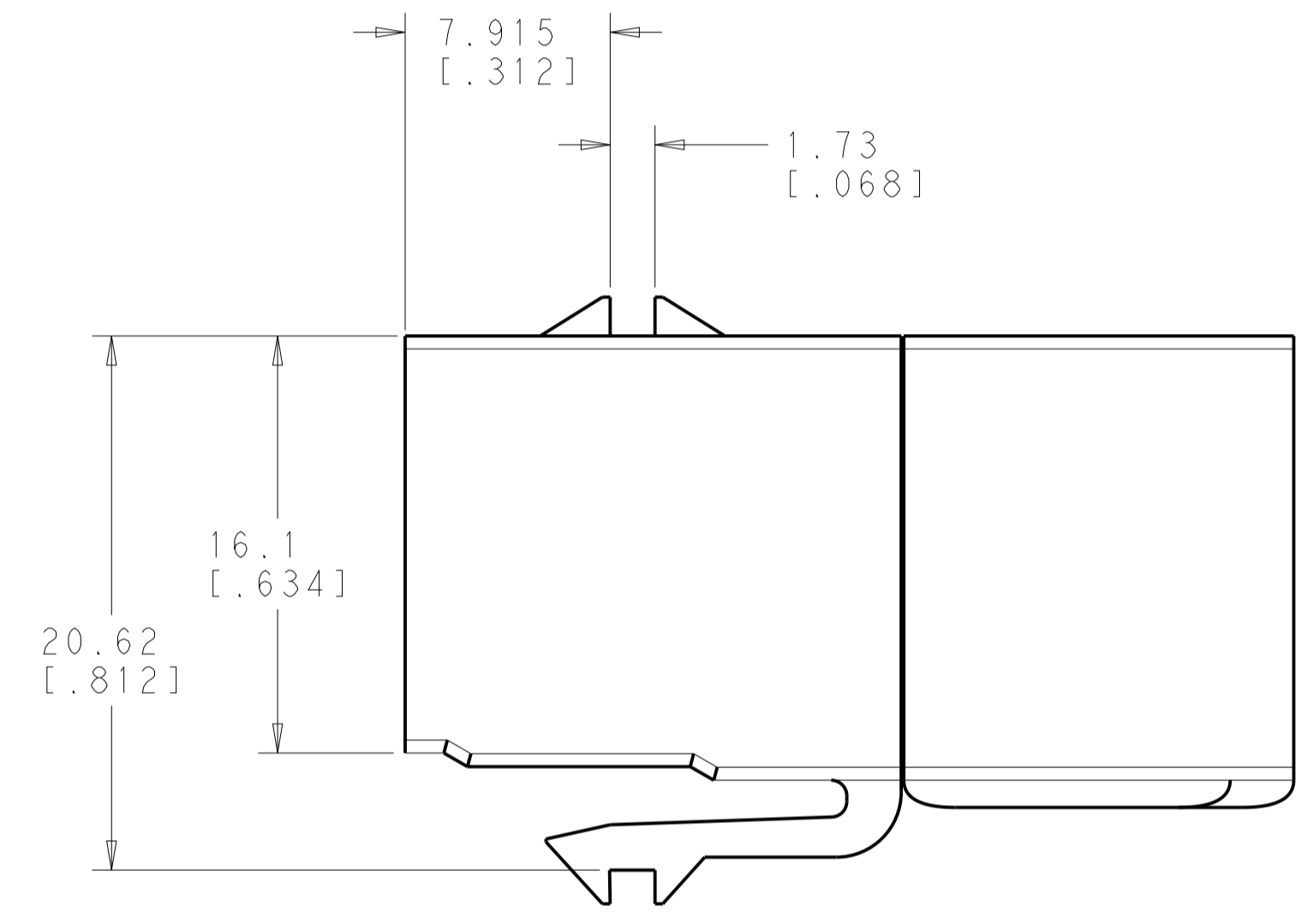
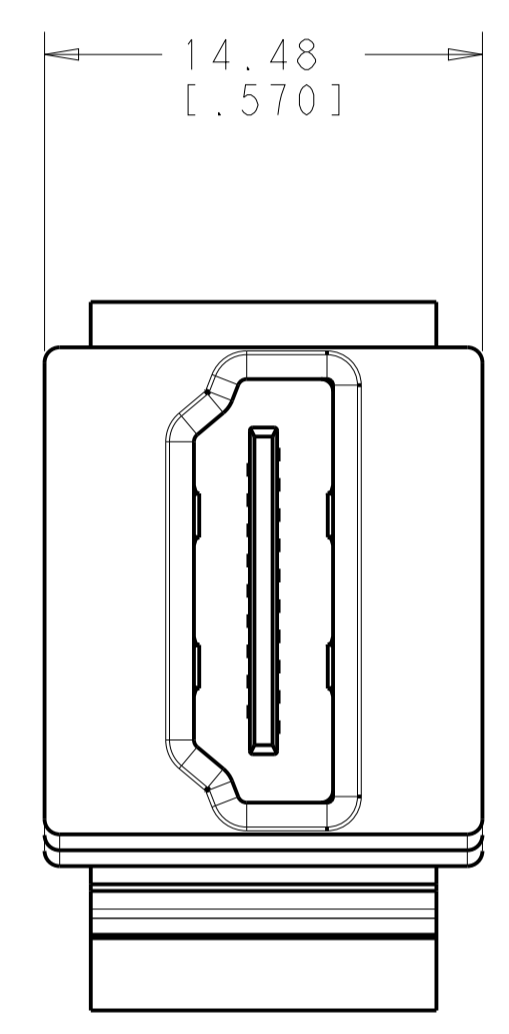

SINGLE PANEL CUTOUT

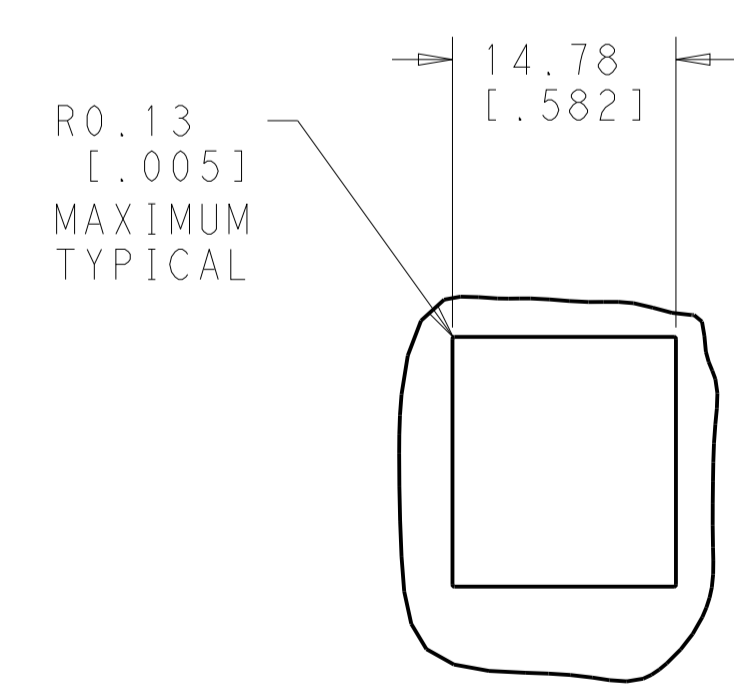
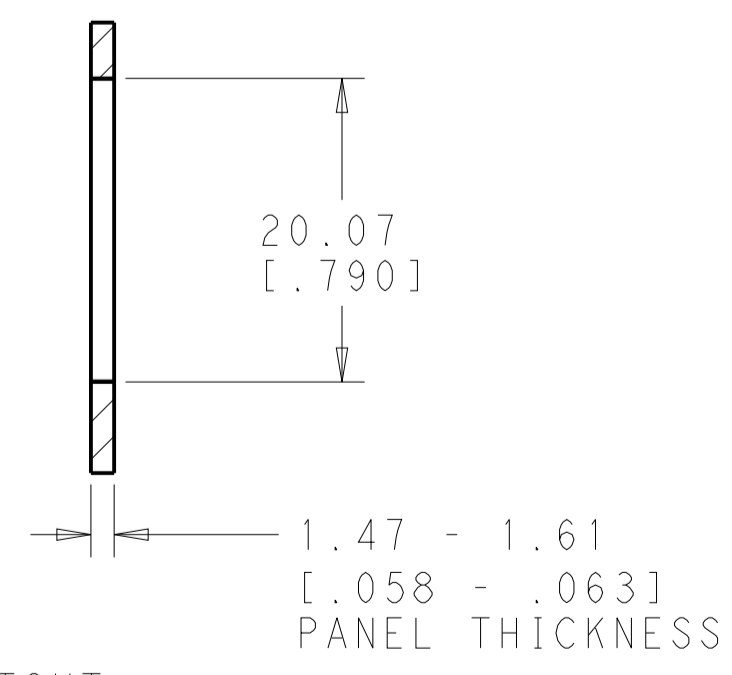

SUGGESTED FLUSH MOUNT
PANEL APPLICATION CUTOUT

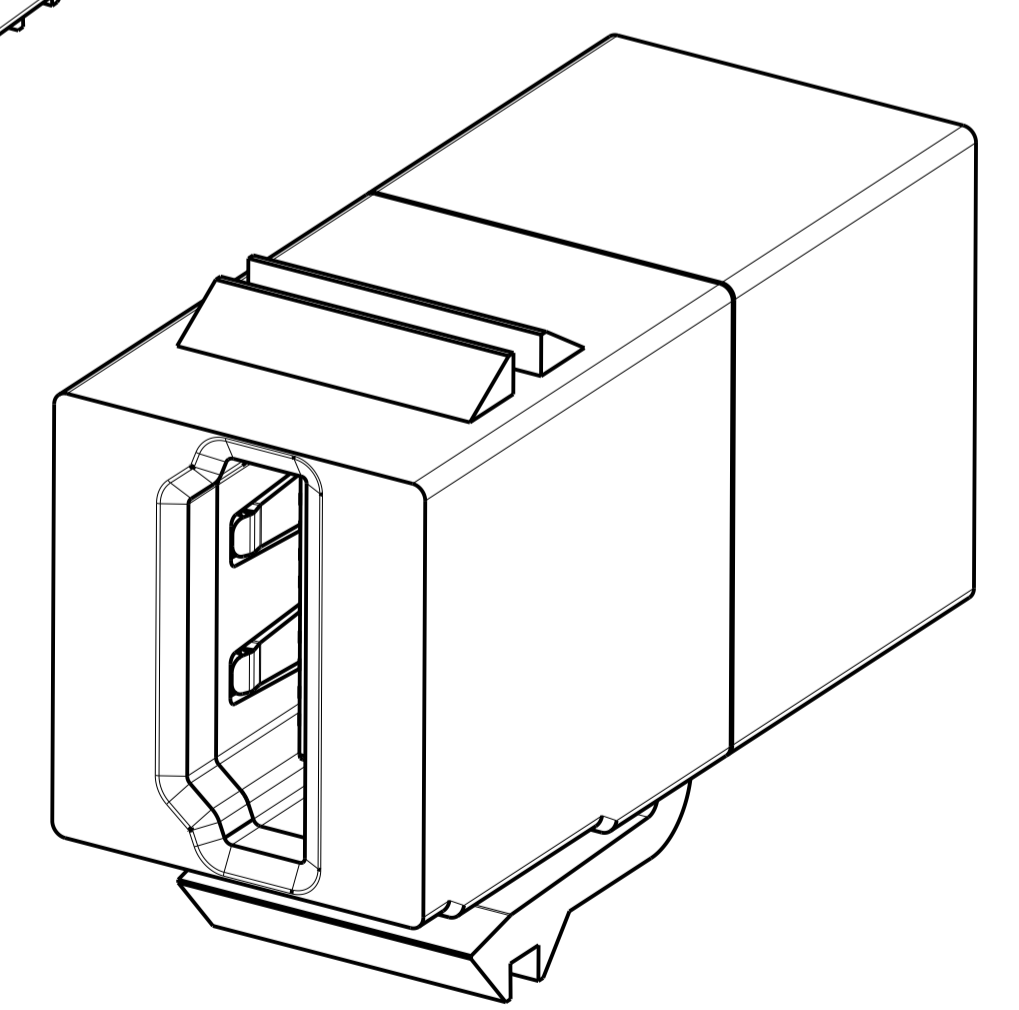
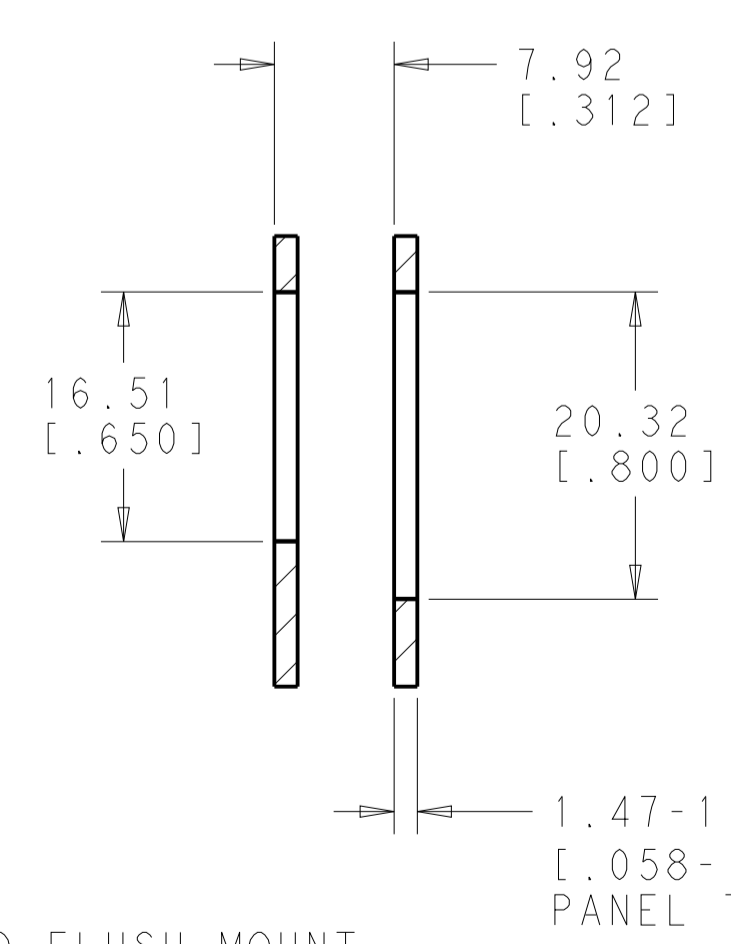

BLACK	2111500-2
COLOR	PART NUMBER

THIS DRAWING IS A CONTROLLED DOCUMENT.		DWN: G. GARRETT 14APR2010	COMMSCOPE, INC.	
DIMENSIONS: mm [INCHES]		CHK: R. ASHBY 14APR2010	HDMI COUPLER, SL	
TOLERANCES UNLESS OTHERWISE SPECIFIED:		APP'D: R. ASHBY 14APR2010	RESTRICTED TO	
0 PLC	±	PRODUCT SPEC	SIZE	CAGE CODE
1 PLC	±	APPLICATION SPEC	A1	2111500
2 PLC	±	WEIGHT	SCALE	4:1
3 PLC	±	CUSTOMER DRAWING	SHEET	1 OF 1
4 PLC	±		REV	B
ANGLES	±			
FINISH	-			