

Section 2: Actuators

Overview - Actuators	14	Non-spring Return N05 Series	
Direct Coupled Actuators		Product Selection	15
Product Selection	15	Submittal Data.....	24
Fire and Smoke Damper Actuators		Wiring Diagrams	37
Product Selection	16	Accessories	40
Spring Return S03 Series		Non-spring Return N10 Series	
Product Selection	15	Product Selection	15
Submittal Data.....	18	Submittal Data.....	25
Wiring Diagrams	32	Wiring Diagrams	37
Accessories	40	Accessories	40
Spring Return S05 Series		Non-spring Return N20 Series	
Product Selection	15	Product Selection	15
Submittal Data.....	19	Submittal Data.....	26
Wiring Diagrams	32	Wiring Diagrams	38
Accessories	40	Accessories	40
Spring Return S10 Series		Non-spring Return N34 Series	
Product Selection	15	Product Selection	15
Submittal Data.....	20	Submittal Data.....	27
Wiring Diagrams	34	Wiring Diagrams	38
Accessories	40	Accessories	40
Spring Return S20 Series		Spring Return MS4104F, MS4604F, MS8104F	
Product Selection	15	Product Selection	16
Submittal Data.....	21	Submittal Data.....	28
Wiring Diagrams	34	Accessories	40
Accessories	40	Spring Return MS4109F, MS4609F, MS8109F	
Non-spring Return ML6161; ML7161		Product Selection	16
Product Selection	15	Submittal Data.....	29
Submittal Data.....	22	Wiring Diagrams	39
Wiring Diagrams	36	Accessories	40
Accessories	40	Spring Return MS4120F; MS4620F; MS8120F	
Non-spring Return ML6174; ML7174		Product Selection	16
Product Selection	15	Submittal Data.....	30
Submittal Data.....	23	Wiring Diagrams	39
Wiring Diagrams	36	Accessories	40
Accessories	40	Cross Reference - Direct Coupled Actuators	48

Overview - Actuators

Direct Coupled Actuators



Spring Return,
Low Torque

Precise, reliable performance. Lasting value. Ease of installation. Everything you look for in direct-coupled actuators hinges on quality. And quality engineering is what makes Honeywell's complete line of actuators the top performers in the industry. Our global engineering team designs and tests our direct-coupled actuators to exceed rigorous global standards — and to meet Honeywell's own demanding life testing.



Spring Return,
Low Torque

But we don't stop there. Thanks to our continuous improvement process, Honeywell actuators are now easier than ever to install. You'll also benefit from consistent wiring regardless of signal type, common accessories and a simplified selection process.



Spring Return,
High Torque

Honeywell's complete line of building control products, including valves and actuators, are already proven in more than three million buildings worldwide. So when you need spring or non-spring return actuators for your damper and valve applications, specify Honeywell. We make precision easy.



Non-Spring Return,
Low Torque

EASY-TO-SELECT MODEL NUMBERS MS, MN, and Diamond Families

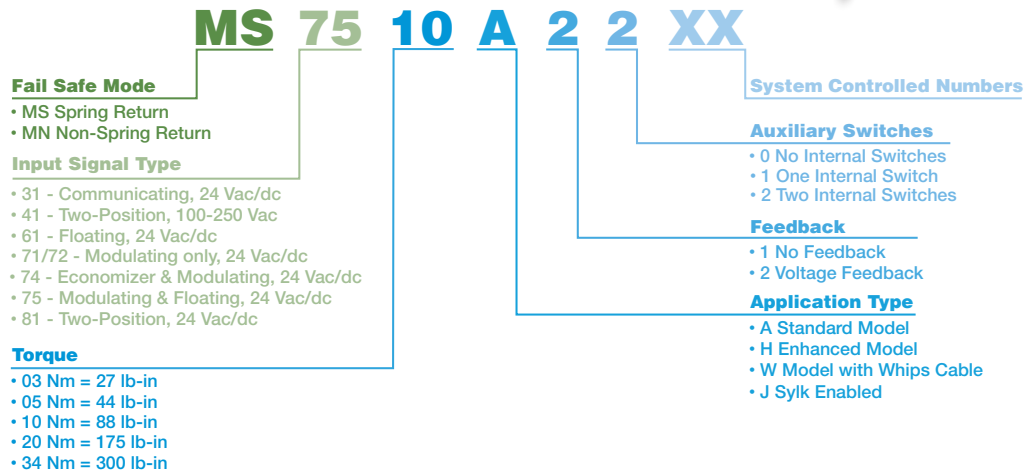

Non-Spring Return,
High Torque



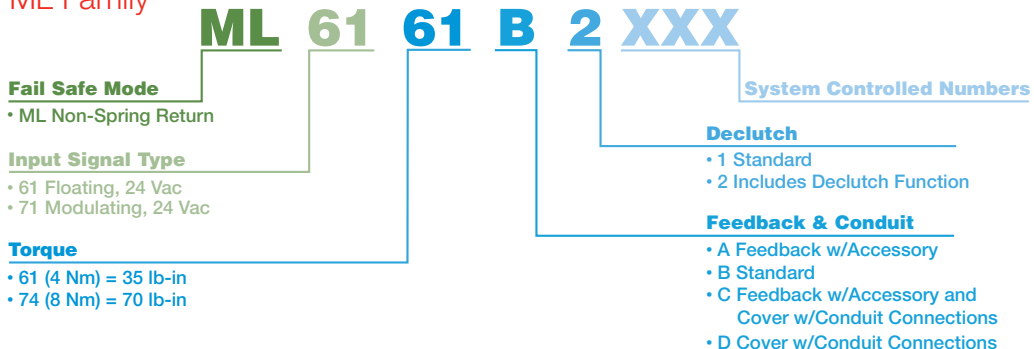

ML Family



Product Selection - Actuators

Direct Coupled Actuators







SPRING RETURN

Order Specification Number (without whips)	Order Specification Number (with whips)	Damper Area (4.5 lb-in/sq. ft.)	Running Time		Power Supply		Control Input/Output							SPDT Auxiliary Switches	
			Drive (sec)	Spring Return (sec)	24 Vac/dc	120-230 Vac	VA Rating (Running)	Sylk-Enabled	On/Off	0/2-10 Vdc	Floating	3 kOhm NTC, 3-Position	Feedback (0/2-10 Vdc)		Adj. Zero and Span
Diamond 3 Nm (3 Nm, 27 lb-in)															
	MS7103A1021	6	90	<25	•	•	4				•**				0
	MS7103A2021	6	90	<25	•	•	4				•**				0
	MS7103A2221	6	90	<25	•	•	4				•**				2 (SPST)
	MS7503A2021	6	90	<25	•	•	4				•	•			0
	MS7503A2221	6	90	<25	•	•	4				•	•			2 (SPST)
S03 Series (3 Nm, 27 lb-in)															
	MS4103A1030	6	45	<25		•	9			•					0
	MS4103A1130	6	45	<25		•	9			•					1
	MS8103A1030	6	45	<25	•	•	6			•					0
	MS8103A1130	6	45	<25	•	•	6			•					1
	MS3103J1030	6	90	<25	•	•	6		•						0
	MS7503A2030	6	90	<25	•	•	6				•	•			0
	MS7503A2130	6	90	<25	•	•	6				•	•			1
	MS7403A2030*	6	90	<25	•	•	6				•	•	•		0
S05 Series (5 Nm, 44 lb-in)															
	MS4105A1030	10	45	<25		•	9			•					0
	MS4105A1130	10	45	<25		•	9			•					1
	MS8105A1030	10	45	<25	•	•	6			•					0
	MS8105A1130	10	45	<25	•	•	6			•					1
	MS3105J3030	10	90	<25	•	•	6		•						0
	MS3105J3130	10	90	<25	•	•	6		•						1
	MS7505A2030	10	90	<25	•	•	6				•	•			0
	MS7505A2130	10	90	<25	•	•	6				•	•			1
	MS7405A2030*	10	90	<25	•	•	6				•	•	•		0
S10 Series (10 Nm, 88 lb-in)															
	MS4110A1002	20	45	<25		•	45			•					0
	MS4110A1200	20	45	<25		•	45			•					2
	MS8110A1008	20	45	<25	•	•	30			•					0
	MS8110A1206	20	45	<25	•	•	30			•					2
	MS3110J1008	20	90	<25	•	•	14		•						0
	MS3110J1206	20	90	<25	•	•	14		•						2
	MS7510A2008	20	90	<25	•	•	14				•	•			0
	MS7510A2206	20	90	<25	•	•	14				•	•			2
	MS7510H2209	20	90	<25	•	•	14				•	•	•		2
S20 Series (20 Nm, 175 lb-in)															
	MS4120A1001	39	45	<25		•	60			•					0
	MS4120A1209	39	45	<25		•	60			•					2
	MS8120A1007	39	45	<25	•	•	40			•					0
	MS8120A1205	39	45	<25	•	•	40			•					2
	MS3120J1007	39	90	<25	•	•	16		•						0
	MS3120J1205	39	90	<25	•	•	16		•						2
	MS7520A2007	39	90	<25	•	•	16				•	•			0
	MS7520A2205	39	90	<25	•	•	16				•	•			2
	MS7520H2208	39	90	<25	•	•	16				•	•	•		2

* Model includes Internal Minimum Position Potentiometer

**2-10 Vdc control only

NON-SPRING RETURN

Order Specification Number (without whips)	Order Specification Number (with whips)	Damper Area (4.5 lb-in/sq. ft.)	Running Time	Power Supply		Control Input/Output							SPDT Auxiliary Switches		
				24 Vac/dc	24 Vac	VA Rating (Running)	On/Off	Floating	0/2-10 Vdc	2-10 Vdc	Feedback (0/2-10 Vdc)				
N05 Series (5 Nm, 44 lb-in)															
	MN6105A1011	MN6105W1011	10	90	•	•	5			•	•				0
	MN6105A1201		10	90	•	•	5			•	•				2
	MN7505A2001	MN7505W2001	10	90	•	•	5			•	•				0
	MN7505A2209		10	90	•	•	5			•	•				2
N10 Series (10 Nm, 88 lb-in)															
	MN6110A1003		20	90	•	•	5			•	•				0
	MN6110A1201		20	90	•	•	5			•	•				2
	MN7510A2001		20	90	•	•	5			•	•				0
	MN7510A2209		20	90	•	•	5			•	•				2
N20 Series (20 Nm, 175 lb-in)															
	MN6120A1002		39	90	•	•	6			•	•				0
	MN6120A1200		39	90	•	•	6			•	•				2
	MN7220A2007		39	90	•	•	6			•	•				0
	MN7220A2205		39	90	•	•	6			•	•				2
N34 Series (34 Nm, 300 lb-in)															
	MN6134A1003		67	90	•	•	9			•	•				0
	MN7234A2008		67	90	•	•	8			•	•				0
ML6161/7161 (4 Nm, 35 lb-in)															
	ML6161A2009		8	90	•	•	1.8			•	•			w/ accessory	0
	ML6161A2017		8	420	•	•	1.8			•	•			w/ accessory	0
	ML6161A2025		8	180	•	•	1.8			•	•			w/ accessory	0
	ML6161B2024		8	90	•	•	1.8			•	•				0
	MS6161B2032		8	420	•	•	1.8			•	•				0
	ML6161B2073		8	180	•	•	1.8			•	•				0
	ML6161C2007		8	90	•	•	1.8			•	•			w/ accessory	0
	ML6161D2006		8	90	•	•	1.8			•	•				0
	ML7161A2008		8	90	•	•	5.4			•	•				0
ML6174/7174 (8 Nm, 70 lb-in)															
	ML6174A2002		16	90	•	•	2.4			•	•			w/ accessory	0
	ML6174A2010		16	180	•	•	2.4			•	•			w/ accessory	0
	ML6174B2019		16	90	•	•	2.4			•	•				0
	ML6174B2035		16	420	•	•	2.4			•	•				0
	ML6174D2009		16	90	•	•	2.4			•	•				0
	ML6174E2008		16	90	•	•	2.4			•	•				0
	ML7174A2001		16	90	•	•	5.4			•	•				0
	ML7174E2007		16	90	•	•	5.4			•	•				0

Product Selection - Actuators

Fire and Smoke Damper Actuators

Honeywell's complete line of two position, fast-acting spring-return actuators meets all of your needs for fire and smoke control applications. All models are designed to meet the UL-555 and UL-555S high temperature requirements for fire dampers and combined fire and smoke dampers.

Safety First

As a life safety system component Honeywell is dedicated to meeting the UL-555 and UL-555S requirements. The elevated temperature test can be performed at the temperature ratings of 250°F or 350°F. Honeywell only offers models at 350°F to meet UL-555 and UL-555S for fire and combined fire and smoke applications to support the highest level of safety for building occupants.

Largest Torque Range in the Industry

Honeywell's fire and smoke actuators are available in 30, 80 and 175 lb-in with the 175 lb-in being the highest torque commercial fire and smoke actuator available on the market today.

Features

- Integral spring return that ensures the proper level of torque
- Patented design that eliminated limit switches, reducing power consumption
- Reliable service in smoke control systems requiring Underwriter's Laboratories Inc. UL-555 and UL-555S
- Robust die-cast aluminum housing ensures the proper level of torque
- Full life of two-position spring return fire and smoke actuators rated up to 350°F for all critical applications
- Fast acting with a maximum spring return timing of 15 seconds
- No audible noise during holding
- Reversible ("flippable") design enables one model to be used for both clockwise and counterclockwise spring return applications

Fire and Smoke Spring Return Actuators



Torque	Model Number	Voltage	SPST Aux Switch	Legacy Honeywell	Belimo Cross	Siemens Cross
30 lb-in (3.4 Nm)	MS4104F1010	120 Vac	0	ML4115A1009 ML4115A1017 ML4115B1008 ML4115B1016 ML4115H1002 ML4115J1009 ML4202F1000 ML4302F1008	FSLF120 US	None
	MS4104F1210	120 Vac	2 Internal	None	FSLF120-S US	None
	MS4604F1010	230 Vac	0	ML4115C1007 ML4115C1015 ML4115D1006 ML4115D1014 ML4702F1009 ML4802F1007	FSLF230 US	None
	MS4604F1210	230 Vac	2 Internal	None	FSLF230-S US	None
	MS8104F1010	24 Vac	0	ML8115A1005 ML8115A1013 ML8115B1004 ML8115B1012 ML8115H1008 ML8115J1005 ML8202F1006 ML8302F1004	FSLF24 US	None
	MS8104F1210	24 Vac	2 Internal	None	FSLF24-S US	None
80 lb-in (9 Nm)	MS4109F1010	120 Vac	0	MS4209F1007 MS4309F1005	FSNF120 US	GND221.1U
	MS4109F1210	120 Vac	2 Internal	None	FSNF120-S US	GND226.1U
	MS4609F1010	230 Vac	0	MS4709F1014 MS4809F1012	FSNF230 US	GND321.1U
	MS4609F1210	230 Vac	2 Internal	None	FSNF230-S US	GND326.1U
	MS8109F1010	24 Vac	0	MS8209F1003 MS8309F1001	FSNF24 US	GND121.1U
	MS8109F1210	24 Vac	2 Internal	None	FSNF24-S US	GND126.1U
175 lb-in (20 Nm)	MS4120F1006	120 Vac	0	None	FSAF120 US	GGD221.1U
	MS4120F1204		2 Internal		FSAF120-S US	None
	MS4620F1005	230 Vac	0		FSAF230 US	GGD321.1U
	MS4620F1203		2 Internal		FSAF230-S US	None
	MS8120F1002	24 Vac	0		FSAF24 US	GGD121.1U
	MS8120F1200		2 Internal		FSAF24-S US	None

Note: Honeywell's spring return fire and smoke actuators are designed to pass UL-555 and UL-555S 350°F requirements. They are not designed for HVAC applications. UL-555 and UL-555S requires that all new construction fire and smoke damper jobs have the actuator assembled and tested at the damper manufacturer. A like for like retrofit replacement or technically equal UL-555 and UL-555S approved device is recommended.



MS7103 and MS7503 Spring Return Direct Coupled Actuators (DCA) are used within heating, ventilating and air-conditioning (HVAC) systems. They can drive a variety of quarter-turn, final control elements requiring spring return fail-safe operation.

FEATURES

- Brushless DC submotor with electronic stall protection
- Self-centering shaft adaptor (shaft coupling) for wide range of shaft sizes
- Fast test mode
- MS7103 models for use with 2-10 Vdc control
- MS7503 universal models for use with floating, 0(2)-10 Vdc or 10-(2)0 Vdc control
- Models available with two internal end switches
- Durable plastic housing with built-in mechanical end limits
- Spring return direction field selectable
- Shaft position indicator and scale
- UL (cUL) listed and CE compliant
- Plenum rated actuator and control/power cable

SPECIFICATIONS

Actuator Type	Damper; Valve
Rotational Stroke	95 ±3 degrees
Fail Safe Mode	Spring Return
Torque	27 lb-in. (3 Nm)
Spring Return Torque	27 lb-in (3 Nm)
Spring Return Direction	By orientation
External Auxiliary Switches Available...	No
Cable Specification	300 V, 75° C, Plenum Rated, 3 ft (0.914 m) length from end of access cover, 18 AWG
Ingress Protection Rating	IP54
Environmental Rating	NEMA2
Frequency	50 Hz; 60 Hz
Mounting	Direct Coupled
Maximum Noise Rating, Driving (dBA @ 1m)	40
Maximum Noise Rating, Spring Return (dBA @ 1m).....	65
Rotation to Open	By switch
Rotational Stroke Adjustment	Mechanically limited 5 degree increments
Compatible Damper Shafts	3/8 to 5/8 in. round or 1/4 to 1/2 in. square (9 to 16 mm round or 6 to 13 mm square)
Shaft Adapter Type	Self-centering clamping
Materials.....	Plenum rated plastic housing
Operating Humidity Range (% RH).....	5 to 95% RH, non-condensing
Ambient Operating Temperature.....	-40 F to +150F (-40 C to +65 C)
Shipping and Storage Temperature.....	-40 F to +150F (-40 C to +65 C)
Weight	1.7 lb (0.78 kg)
Includes.....	Mounting bracket, self- centering shaft adapter

APPROVALS

CE.....	EMC 2004/108/EC; Certification Low Voltage Directive 2006/95/EC; IEC 60730-1 and Part 2-14
C-Tick	N314
Underwriters Laboratories, Inc.....	UL 60730; UL 1097 for Double Insulation

DIMENSIONS DIAGRAM

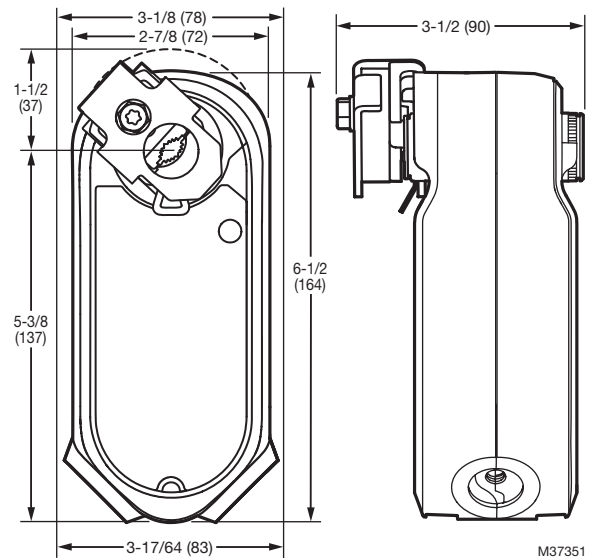

Submittal Data - Actuators

Spring Return S03 Series



MS4103, MS7403, MS7503 and MS8103 Spring Return Direct Coupled Actuators (DCA) are used within heating, ventilating and air-conditioning (HVAC) systems. They can drive a variety of quarter-turn, final control elements requiring spring return fail-safe operation.

FEATURES

- Brushless DC submotor with electronic stall protection on all models
- Self-centering shaft adaptor (shaft coupling) for wide range of shaft sizes
- Models available for use with two-position, SPST, line- (Series 40) or low- (Series 80) voltage controls
- Models available for use with floating or switched SPDT (Series 60) controls
- Models available for use with proportional current or voltage (Series 70) controls
- Models available with combined floating and modulating control in a single device
- Models available with an internal end switch
- Access cover to facilitate connectivity
- Durable plastic housing with built-in mechanical end limits
- Spring return direction field selectable
- Shaft position indicator and scale
- UL (cUL) listed and CE compliant
- All models are plenum rated per UL873

SPECIFICATIONS

Actuator Type	Damper; Valve
Rotational Stroke	95 ±3 degrees
Fail Safe Mode	Spring Return
Torque	27 lb-in. (3 Nm)
Spring Return Torque	27 lb-in (3 Nm)
Spring Return Direction.....	By orientation
External Auxiliary Switches Available...	No
Electrical Connections	Enclosed screw terminal strip (22 to 14 AWG)
Ingress Protection Rating	IP54
Environmental Rating	NEMA2
Frequency	50 Hz; 60 Hz
Mounting	Direct Coupled
Maximum Noise Rating, Holding (dBA @ 1m)	20 (no audible noise)
Maximum Noise Rating, Driving (dBA @ 1m)	50
Rotation to Open	By switch
Rotational Stroke Adjustment	Mechanically limited 5 degree increments
Compatible Damper Shafts.....	3/8 to 5/8 in. round or 1/4 to 1/2 in. square (9 to 16 mm round or 6 to 13 mm square)
Shaft Adapter Type	Self-centering clamping
Materials	Plenum rated plastic housing
Operating Humidity Range (% RH).....	5 to 95% RH, non-condensing
Ambient Temperature Range	-40 F to +149F (-40 C to +65 C) -22 F to +149F (-30 C to +65 C) for two-position actuators only
Temperature Ratings (Shipping)	-40 F to +150F (-40 C to +65 C)
Storage Temperature Range	-40 F to +150F (-40 C to +65 C)
Weight	3.5 lb (1.6 kg)
Includes.....	Mounting bracket, self-centering shaft adapter

APPROVALS

CE.....	EMC 2004/108/EC; Certification Low Voltage Directive 2006/95/EC; IEC 60730-1 and Part 2-14
C-Tick	N314
Underwriters Laboratories, Inc.....	UL 873
Canadian Underwriters Laboratories, Inc.	cUL C22.2 No. 24-93

DIMENSIONS DIAGRAM

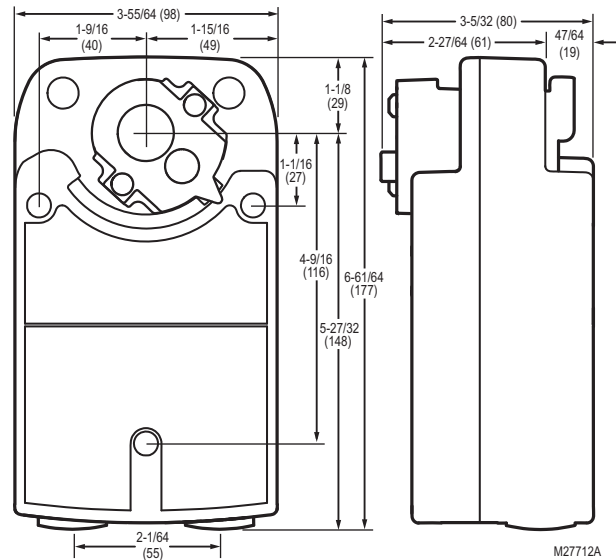



MS4105, MS7405, MS7505, and MS8105 Spring Return Direct Coupled Actuators (DCA) are used within heating, ventilating and air-conditioning (HVAC) systems. They can drive a variety of quarter-turn, final control elements requiring spring return fail-safe operation.

FEATURES

- Brushless DC submotor with electronic stall protection on all models
- Self-centering shaft adaptor (shaft coupling) for wide range of shaft sizes
- Models available for use with two-position, SPST, line- (Series 40) or low- (Series 80) voltage controls
- Models available for use with floating or switched SPDT (Series 60) controls
- Models available for use with proportional current or voltage (Series 70) controls
- Models available with combined floating and modulating control in a single device
- Models available with an internal end switch
- Access cover includes enclosed screw terminal strip (22 to 14 AWG) for electrical connections.
- Models available with 3 foot 18 AWG color-coded cable
- Durable plastic housing with built-in mechanical end limits
- Spring return direction field selectable
- Shaft position indicator and scale
- UL (cUL) listed and CE compliant
- All models are plenum rated per UL873

SPECIFICATIONS

Actuator Type	Damper; Valve
Rotational Stroke	95 ±3 degrees
Fail Safe Mode	Spring Return
Torque	44 lb-in. (5 Nm)
Spring Return Torque	44 lb-in. (5 Nm)
Spring Return Direction	By orientation
External Auxiliary Switches Available	No
Environmental Rating	NEMA2
Ingress Protection Rating	IP54
Frequency	50 Hz; 60 Hz
Mounting	Direct Coupled
Maximum Noise Rating, Holding (dBA @ 1m)	20 (no audible noise)
Maximum Noise Rating, Driving (dBA @ 1m)	50
Rotation to Open	By switch
Rotational Stroke Adjustment	Mechanically limited 5 degree increments
Compatible Damper Shafts	3/8 to 5/8 in. round or 1/4 to 1/2 in. square (9 to 16 mm round or 6 to 13 mm square)
Shaft Adapter Type	Self-centering clamping
Materials	Plenum rated plastic housing
Operating Humidity Range (% RH)	5 to 95% RH, non-condensing
Ambient Temperature Range	-40 F to +149F (-40 C to +65 C) -22 F to +149F (-30 C to +65 C) for two-position actuators only
Temperature Ratings (Shipping)	-40 F to +150F (-40 C to +65 C)
Storage Temperature Range	-40 F to +150F (-40 C to +65 C)
Weight	3.5 lb (1.6 kg)
Includes	Mounting bracket, self-centering shaft adapter

APPROVALS

CE	EMC 2004/108/EC; Certification Low Voltage Directive 2006/95/EC; IEC 60730-1 and Part 2-14
C-Tick	N314
Underwriters Laboratories, Inc.	UL 873
Canadian Underwriters Laboratories, Inc.	cUL C22.2 No. 24-93

DIMENSIONS DIAGRAM

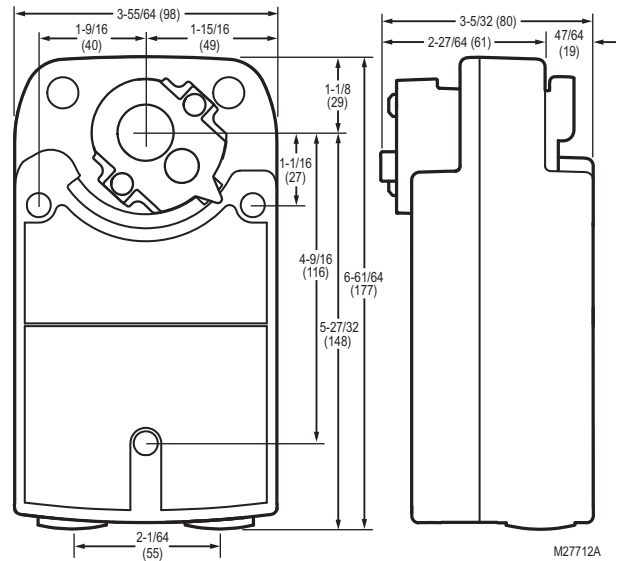

Submittal Data - Actuators

Spring Return S10 Series



MS4110, MS7510 and MS8110 Spring Return Direct Coupled Actuators (DCA) are used within heating, ventilating and air-conditioning (HVAC) systems. They can drive a variety of quarter-turn, final control elements requiring spring return fail-safe operation.

FEATURES

- Brushless DC submotor with electronic stall protection for floating/modulating models.
- Brush DC submotor with electronic stall protection for 2-position models.
- Self-centering shaft adapter (shaft coupling) for wide range of shaft sizes.
- Models available for use with two-position, single pole single throw (spst), line- (Series 40) or low- (Series 80) voltage controls.
- Models available for use with proportional current or voltage (Series 70) controls.
- Models available with combined floating/modulating control in a single device.
- Models available with adjustable zero and span.
- Models available with line-voltage internal end switches.
- Access cover includes enclosed screw terminal strip (22 to 14 AWG) for electrical connections.
- Models available with 3 foot 18 AWG color-coded cable.
- Metal housing with built-in mechanical end limits.
- Spring return direction field-selectable.
- Shaft position indicator and scale.
- Manual winding capability with locking function.
- UL (cUL) listed and CE compliant.
- All Models are plenum-rated per UL873.

SPECIFICATIONS

Actuator Type	Damper; Valve
Rotational Stroke	95 ±3 degrees
Fail Safe Mode	Spring Return
Torque	88 lb-in. (10 Nm)
Spring Return Torque	88 lb-in. (10 Nm)
Spring Return Direction.....	By orientation
External Auxiliary Switches Available...	Yes, SW2-US
Environmental Rating	NEMA2
Frequency	50 Hz; 60 Hz
Manual operation	Manual crank
Mounting	Direct Coupled
Maximum Noise Rating, Holding (dBA @ 1m)	20 (no audible noise)
Maximum Noise Rating, Driving (dBA @ 1m).....	40
Rotational Stroke Adjustment.....	Mechanically limited 5 degree increments
Compatible Damper Shafts.....	3/8 to 1.06 in. round or 3/8 to 11/16 in. square (10 to 27 mm round or 10 to 18 mm square)
Shaft Adapter Type	Self-centering clamping
Materials.....	Aluminum housing, Plenum rated plastic access cover
Operating Humidity Range (% RH).....	5 to 95% RH, non-condensing
Ambient Temperature Range	-40 F to +140 F (-40 C to +60 C)
Storage Temperature Range	-40 F to +158 F (-40 C to +70 C)
Weight	6 lb (2.72 kg)
Includes.....	Mounting bracket, self-centering shaft adapter, 3mm crank
Comments.....	Integral 1/2 in. NPSM conduit connection.

APPROVALS

CE.....	89/336/ECC, 73/23/EEC
C-Tick	N314
Underwriters Laboratories, Inc.....	UL873, Plenum Rated
Canadian Underwriters Laboratories, Inc.	cUL C22.2 No. 24-93

DIMENSIONS DIAGRAM

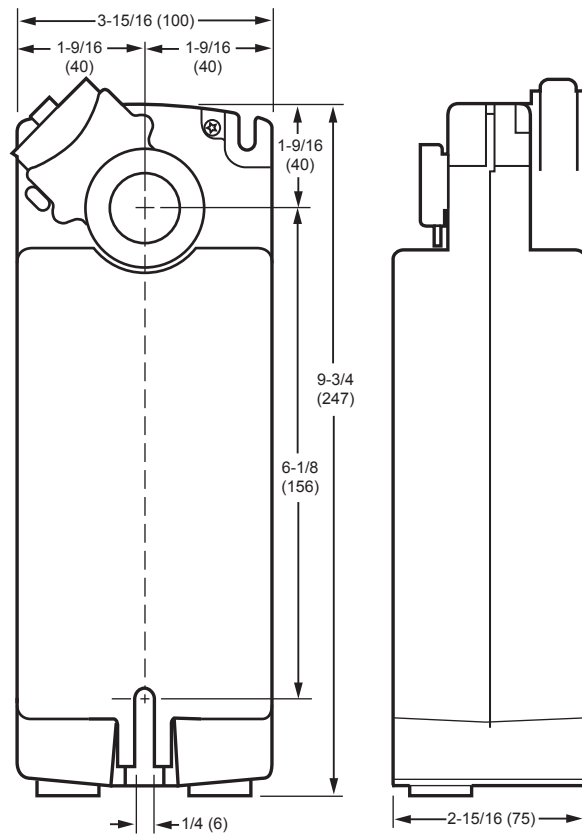

M20952



MS4120, MS7520 and MS8120 Spring Return Direct Coupled Actuators (DCA) are used within heating, ventilating and air-conditioning (HVAC) systems. They can drive a variety of quarter-turn, final control elements requiring spring return fail-safe operation.

SPECIFICATIONS

Actuator Type	Damper; Valve
Rotational Stroke95 ±3 degrees
Fail Safe Mode.....	Spring Return
Torque.....	175 lb-in. (20 Nm)
Spring Return Torque	175 lb-in. (20 Nm)
Spring Return Direction	By orientation
External Auxiliary Switches Available...	Yes, SW2-US
Environmental Rating	NEMA2
Frequency	50 Hz; 60 Hz
Manual operation.....	Manual crank
Mounting.....	Direct Coupled
Maximum Noise Rating, Holding (dBA @ 1m).....	20 (no audible noise)
Maximum Noise Rating, Driving (dBA @ 1m).....	40
Rotational Stroke Adjustment	Mechanically limited 5 degree increments
Compatible Damper Shafts	3/8 to 1.06 in. round or 3/8 to 1 1/16 in. square (10 to 27 mm round or 10 to 18 mm square)
Shaft Adapter Type.....	Self-centering clamping
Materials	Aluminum housing, Plenum rated plastic access cover
Operating Humidity Range (% RH)	5 to 95% RH, non-condensing
Ambient Temperature Range	-40 F to +140 F (-40 C to +60 C)
Storage Temperature Range	-40 F to +158 F (-40 C to +70 C)
Weight	6 lb (2.72 kg)
Includes.....	Mounting bracket, self-centering shaft adapter, 3mm crank
Comments	Integral 1/2 in. NPSM conduit connection.

APPROVALS

CE.....	89/336/ECC, 73/23/EEC
C-Tick	N314
Underwriters Laboratories, Inc.	UL873, Plenum Rated
Canadian Underwriters Laboratories, Inc.	cUL C22.2 No. 24-93

FEATURES

- Brushless DC submotor with electronic stall protection for floating/modulating models.
- Brush DC submotor with electronic stall protection for 2-position models.
- Self-centering shaft adapter (shaft coupling) for wide range of shaft sizes.
- Models available for use with two-position, single pole single throw (spst), line- (Series 40) or low- (Series 80) voltage controls.
- Models available for use with proportional current or voltage (Series 70) controls.
- Models available with combined floating/modulating control in a single device.
- Models available with adjustable zero and span.
- Models available with line-voltage internal end switches.
- Access cover includes enclosed screw terminal strip (22 to 14 AWG) for electrical connections.
- Models available with 3 foot 18 AWG color-coded cable.
- Metal housing with built-in mechanical end limits.
- Spring return direction field-selectable.
- Shaft position indicator and scale.
- Manual winding capability with locking function.
- UL (cUL) listed and CE compliant.
- All models are plenum-rated per UL873.

DIMENSIONS DIAGRAM

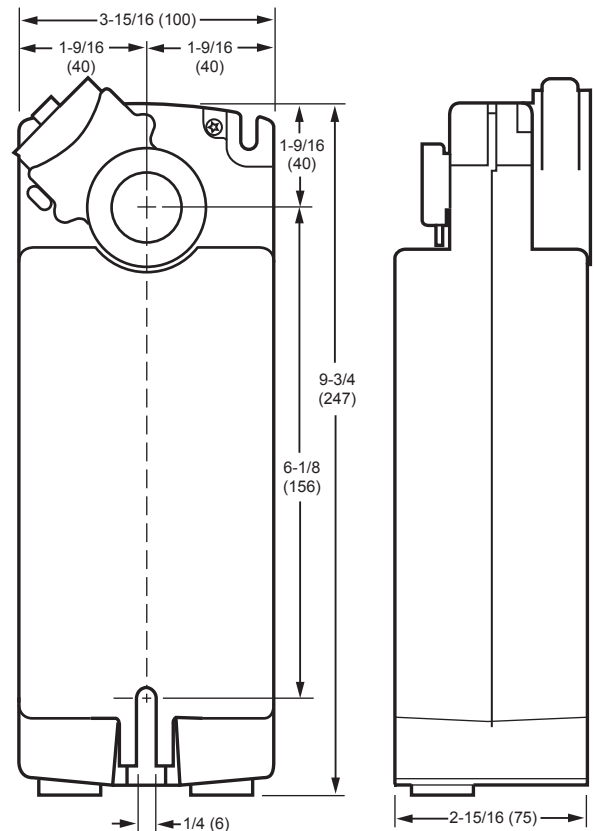

M20952

Submittal Data - Actuators

Non-spring Return ML6161; ML7161

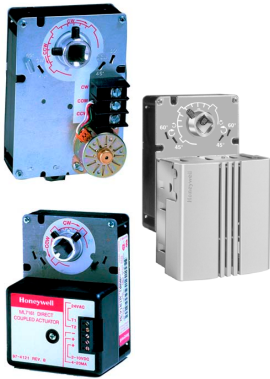

Used to control dampers in applications such as variable air volume (VAV) terminal units and for mounting on ball valves; suitable for use with SPDT or floating thermostats or building automation controls.

FEATURES

- Control for air damper applications with up to 10 sq.ft. assuming 3.5 in-lb per sq.ft. of damper area, velocity independent.
- Superior A/C synchronous submotor for consistent timing and actuator longevity.
- Eliminate need for limit switches or mechanical stops by providing magnetic coupling.
- All models include manual declutch lever and bag assembly with two minimum position setscrews.
- Mount directly on 3/8 inch or 1/2 inch square or round damper shaft.
- Selectable 45, 60 and 90 stroke in either clockwise or counterclockwise direction.

SPECIFICATIONS

Actuator Type	Damper
Rotational Stroke	90 degrees
Fail Safe Mode	Non-Spring Return
Torque	35 lb-in. (4 Nm)
External Auxiliary Switches Available... Yes, 201052B	
Electrical Connections	Screw terminals
Environmental Rating	NEMA 1
Feedback	With accessory
Frequency	50 Hz; 60 Hz
Manual operation	Declutch mechanism
Mounting	Direct Coupled
Maximum Noise Rating, Driving (dBA @ 1m).....	45
Rotation to Open	By wiring
Rotational Stroke Adjustment	Mechanically limited at 45 or 60 degrees in cw or ccw directions
Compatible Damper Shafts	3/8 to 1/2 in. square or round (10 to 13 mm square/round)
Shaft Adapter Type	Aluminum Hub, two set screws
Supply Voltage	24 Vac ±20%
Materials.....	Steel plate and Plenum rated plastic
Operating Humidity Range (% RH).....	5 to 95% RH, non-condensing
Ambient Temperature Range	20 F to 125 F (-18 C to +50 C)
Storage Temperature Range	20 F to 130 F (-18 C to +54 C)
Weight	1.5 lb (0.68 kg)
Includes.....	4074ENY Bag Assembly

APPROVALS

CE.....	89/336/ECC, 73/23/EEC
C-Tick	N314
Underwriters Laboratories, Inc.....	UL873, Plenum Rated
Canadian Underwriters Laboratories, Inc.	cUL C22.2 No. 24-93

DIMENSIONS DIAGRAMS

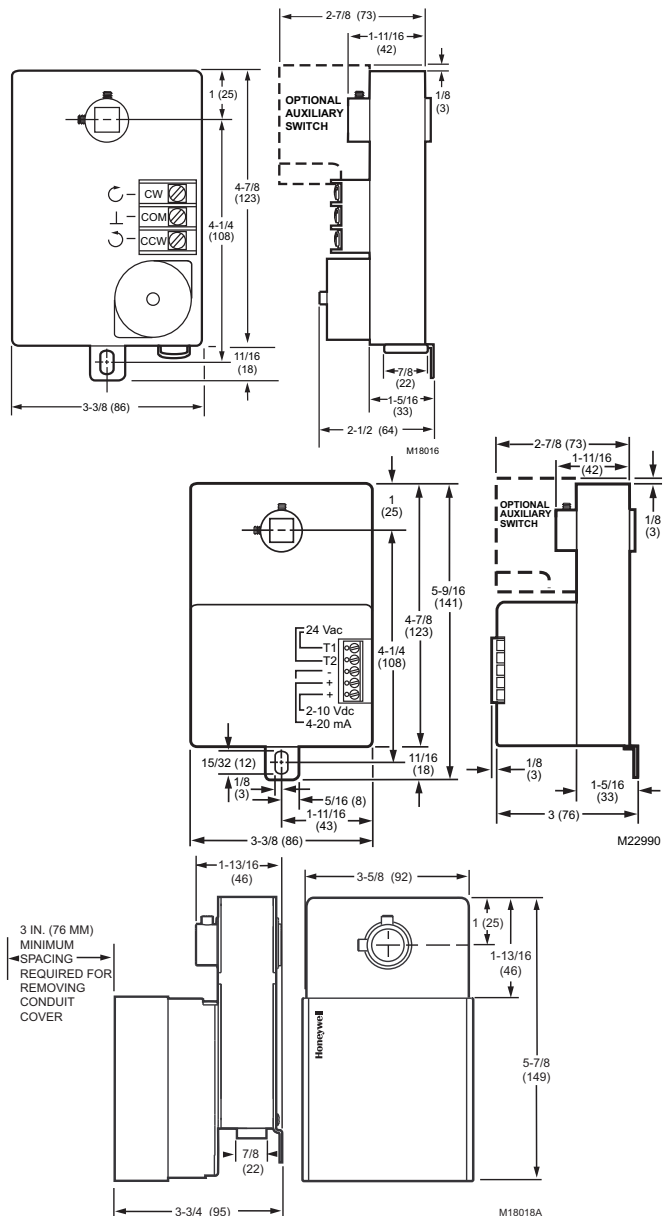

Submittal Data - Actuators

Non-spring Return ML6174; ML7174



Used to control dampers in applications such as variable air volume (VAV) terminal units and for mounting on ball valves; suitable for use with SPDT or floating thermostats or building automation controls.

FEATURES

- Control for air damper applications with up to 20 sq.ft. assuming 3.5 in-lb per sq.ft. of damper area, velocity independent.
- Magnetic coupling eliminates the need for mechanical stops or limit switch adjustments by limiting stall torque to 130 lb-in. maximum.
- Mount directly on 3/8 to 1/2 in. round and square damper shafts. All models include manual declutch lever for ease of mounting and bag assembly with two minimum position setscrews. 90 second timing models are suitable for use with pressure independent VAV systems.
- Selectable 45, 60, and 90 degree stroke in either clockwise or counterclockwise direction.

SPECIFICATIONS

Actuator Type	Damper
Rotational Stroke	90 degrees
Fail Safe Mode	Non-Spring Return
Torque	70 lb-in (8 Nm)
External Auxiliary Switches Available	Yes, 201052B
Environmental Rating	NEMA1
Feedback	With accessory
Frequency	50 Hz; 60 Hz
Manual operation	Declutch mechanism
Mounting	Direct Coupled
Maximum Noise Rating, Driving (dBA @ 1m)	45
Rotation to Open	By wiring
Rotational Stroke Adjustment	Mechanically limited at 45 or 60 degrees in cw or ccw directions
Compatible Damper Shafts	3/8 to 1/2 in. square or round (10 to 13 mm square/round)
Shaft Adapter Type	Aluminum Hub, two set screws
Supply Voltage	24 Vac \pm 20%
Materials	Steel plate and Plenum rated plastic
Operating Humidity Range (% RH)	5 to 95% RH, non-condensing
Ambient Temperature Range	20 F to 125 F (-18 C to +50 C)
Storage Temperature Range	20 F to 130 F (-18 C to +54 C)
Weight	1.5 lb (0.68 kg)
Includes	4074ENY Bag Assembly

APPROVALS

Underwriters Laboratories, Inc.UL873, Plenum Rated
Canadian Underwriters Laboratories, Inc. cUL C22.2 No. 24-93

DIMENSIONS DIAGRAMS

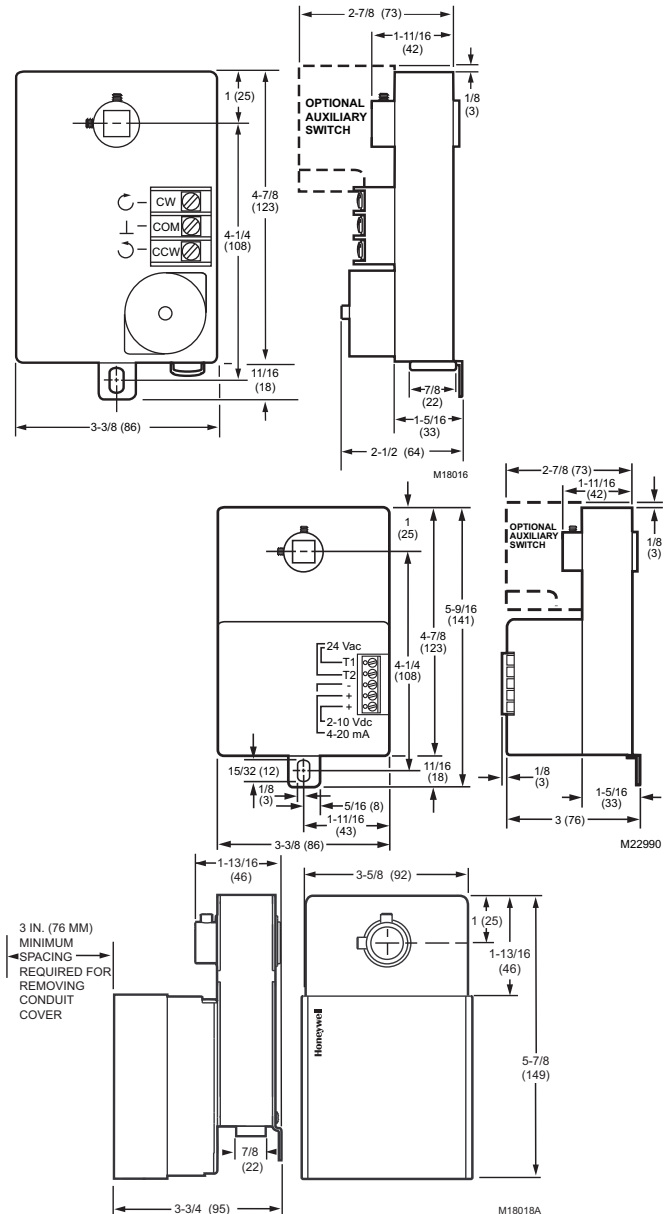

Submittal Data - Actuators

Non-spring Return N05 Series



This non-spring return direct-coupled damper actuator provides modulating and floating/2-position control for: air dampers, air handlers, ventilation flaps, louvers and reliable control for air damper applications with up to 10 sq. ft./44lb.-in. (5 Nm) and 20 sq. ft./88 lb.-in. (10 Nm) (seal-less damper blades; air friction-dependent).

FEATURES

- Declutch for manual adjustment
- Adjustable mechanical end limits
- Access cover includes enclosed screw terminal strip (22 to 14 AWG) for electrical connections
- Models available with 3 foot 18 AWG color-coded cable
- Mountable in any orientation
- Function selection switch for selecting modulating or floating/2-position control

SPECIFICATIONS

Actuator Type	Damper; Valve
Rotational Stroke	95 ±3 degrees
Fail Safe Mode	Non-Spring Return
Torque	44 lb.-in. (5 Nm)
External Auxiliary Switches Available...	Yes, SSW2-1M
Environmental Rating	NEMA2
Frequency	50 Hz; 60 Hz
Manual operation	Declutch mechanism
Mounting	Direct Coupled
Maximum Noise Rating, Driving (dBA @ 1m).....	35
Rotation to Open	By switch
Rotational Stroke Adjustment	Dual Integral Adj. Stops (3 degree increments)
Compatible Damper Shafts.....	1/4 to 1/2 in. square or 3/8 to 5/8 in. round (6 to 13 mm square or 8 to 16 mm round)
Shaft Adapter Type	U-bolt clamp
Supply Voltage	24 Vac +20%, -15%, 24 Vdc
Materials.....	Plenum rated plastic housing
Ingress Protection Rating.....	IP54
Operating Humidity Range (% RH).....	5 to 95% RH, non-condensing
Ambient Temperature Range	-5 F to +140 F (-20 C to +60 C)
Storage Temperature Range	-22 F to +176 F (-30 C to +80 C)
Weight	1 lb (0.45 kg)
Includes.....	Mounting bracket, screws, shaft adapter, water-tight strain-relief cable fittings
Comments	Integral 1/2 in. NPSM conduit connection.

APPROVALS

CE.....	89/336/ECC, 73/23/EEC
C-Tick.....	N314
Underwriters Laboratories, Inc.....	UL873, Plenum Rated
Canadian Underwriters Laboratories, Inc.	cUL C22.2 No. 24-93

DIMENSIONS DIAGRAM

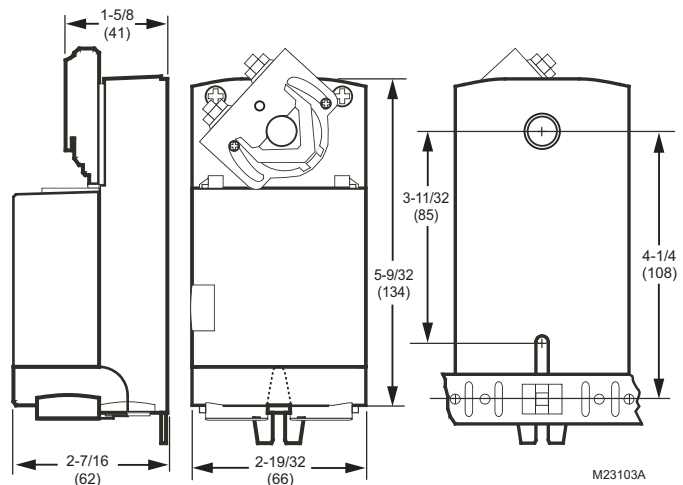

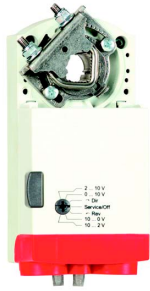

This non-spring return direct-coupled damper actuator provides modulating and floating/2-position control for air dampers, air handlers, ventilation flaps, louvers and reliable control for air damper applications with up to 20 sq ft/88 lb-in. (10 Nm) (seal-less damper blades; air friction-dependent).

FEATURES

- Declutch for manual adjustment
- Adjustable mechanical end limits
- Removable access cover for direct wiring
- Mountable in any orientation
- Function selection switch for selecting modulating or floating/2-position control

SPECIFICATIONS

Actuator Type	Damper; Valve
Rotational Stroke	95 ±3 degrees
Fail Safe Mode	Non-Spring Return
Torque	88 lb-in. (10 Nm)
External Auxiliary Switches Available	Yes, SSW2-1M
Electrical Connections	Enclosed screw terminal strip (22 to 14 AWG)
Environmental Rating	NEMA2
Frequency	50 Hz; 60 Hz
Manual operation	Declutch mechanism
Mounting	Direct Coupled
Maximum Noise Rating, Driving (dBA @ 1m)	35
Rotation to Open	By switch
Rotational Stroke Adjustment	Dual Integral Adj. Stops (3 degree increments)
Compatible Damper Shafts	1/4 to 1/2 in. square or 3/8 to 5/ 8 in. round (6 to 13 mm square or 8 to 16 mm round)
Shaft Adapter Type	U-bolt clamp
Supply Voltage	24 Vac +20%, -15%, 24 Vdc
Materials	Plenum rated plastic housing
Ingress Protection Rating	IP54
Operating Humidity Range (% RH)	5 to 95% RH, non-condensing
Ambient Temperature Range	-5 F to +140 F (-20 C to +60 C)
Storage Temperature Range	-22 F to +176 F (-30 C to +80 C)
Weight	1 lb (0.45 kg)
Includes	Mounting bracket, screws, shaft adapter, water-tight strain-relief cable fittings
Comments	Integral 1/2 in. NPSM conduit connection.

APPROVALS

CE	89/336/ECC, 73/23/EEC
C-Tick	N314
Underwriters Laboratories, Inc.	UL873, Plenum Rated
Canadian Underwriters Laboratories, Inc.	cUL C22.2 No. 24-93

DIMENSIONS DIAGRAM

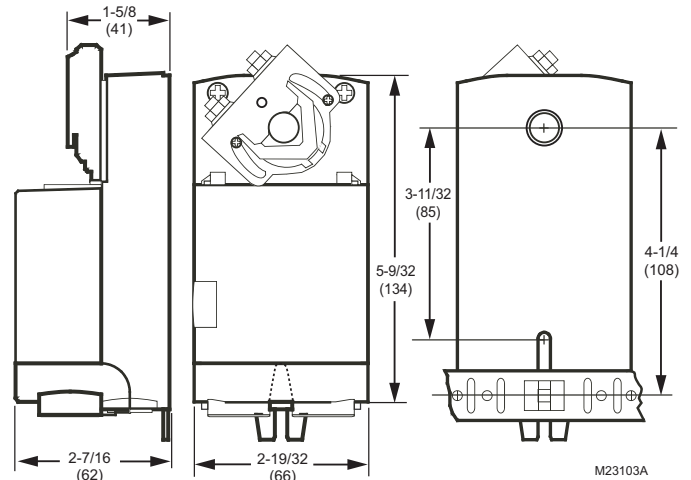

Submittal Data - Actuators

Non-spring Return N20 Series



These direct-coupled damper actuators provide adjustable modulating control for: air dampers, air handling units, ventilation flaps, louvers and reliable control for air damper applications with up to 4.6 m²/50 sq ft (seal-less dampers; air friction-dependent).

FEATURES

- Control for air damper applications with up to 50 sq ft assuming 3.5 in-lb per sq ft of damper area, velocity independent.
- Patented self-centering shaft adapter.
- Access cover to facilitate connectivity.
- Declutch for manual adjustment.
- Mechanical end limits.
- Field-installable auxiliary switches.
- Rotation direction selectable by switch.
- Mountable in any orientation (no IP54 if upside down).
- Mechanical position indicator.
- CE approved. UL approved.

SPECIFICATIONS

Actuator Type	Damper; Valve
Rotational Stroke	95 ±3 degrees
Fail Safe Mode	Non-Spring Return
Torque	175 lb-in. (20 Nm)
External Auxiliary Switches Available...	Yes, SW2-US
Electrical Connections	Enclosed screw terminal strip (22 to 14 AWG)
Environmental Rating	NEMA2; IP54
Frequency	50 Hz; 60 Hz
Manual operation	Declutch mechanism
Mounting	Direct Coupled
Maximum Noise Rating, Driving (dBA @ 1m).....	40
Rotation to Open	By switch
Rotational Stroke Adjustment.....	Dual Integral Adj. Stops (3 degree increments)
Compatible Damper Shafts.....	3/8 to 1.06 in. round or 3/8 to 1 1/16 in. square (10 to 27 mm round or 10 to 18 mm square)
Shaft Adapter Type	Self-centering clamping
Materials.....	Plenum rated plastic housing
Operating Humidity Range (% RH).....	5 to 95% RH, non-condensing
Ambient Temperature Range	-5 F to +140 F (-20 C to +60 C)
Storage Temperature Range	-40 F to +175 F (-40 C to +80 C)
Weight	3.2 lb (1.45 kg)
Includes.....	Mounting bracket, self- centering shaft adapter
Comments.....	Integral 1/2 in. NPSM conduit connection.

APPROVALS

CE.....	89/336/ECC, 73/23/EEC
C-Tick	N314
Underwriters Laboratories, Inc.....	UL873, Plenum Rated
Canadian Underwriters Laboratories, Inc.	cUL C22.2 No. 24-93

DIMENSIONS DIAGRAM

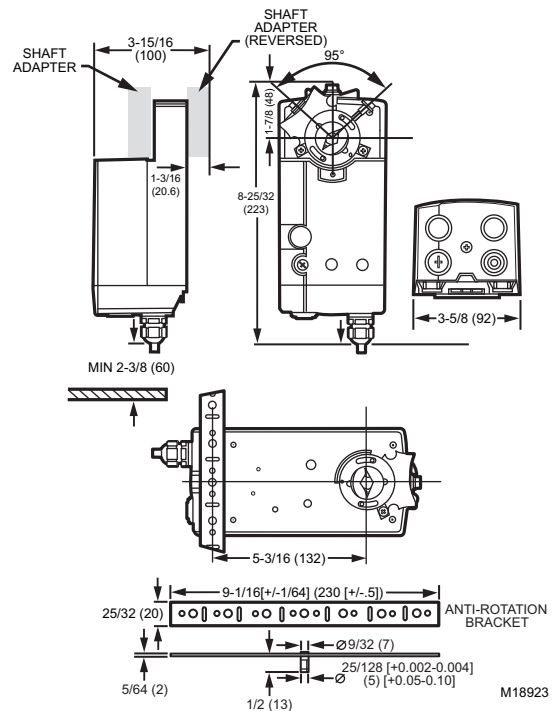



These direct coupled damper actuators provide adjustable modulating control for air dampers, air handling units, ventilation flaps, louvers and reliable control for air damper applications with up to 7.9 m²/85 sq ft (seal-less dampers; air friction-dependent).

FEATURES

- Control for air damper applications with up to 85 sq ft assuming 3.5 in-lb per sq ft of damper area, velocity independent.
- Patented self-centering shaft adapter.
- Access cover to facilitate connectivity.
- Declutch for manual adjustment.
- Mechanical end limits.
- Field-installable auxiliary switches.
- Rotation direction selectable by switch.
- Mountable in any orientation (no IP54 if upside down).
- Mechanical position indicator.
- CE approved. UL approved.

SPECIFICATIONS

Actuator Type	Damper; Valve
Rotational Stroke	95 ±3 degrees
Fail Safe Mode	Non-Spring Return
Torque	300 lb-in. (34 Nm)
External Auxiliary Switches Available	Yes, SW2-US
Electrical Connections	Enclosed screw terminal strip (22 to 14 AWG)
Environmental Rating	NEMA2
Frequency	50 Hz; 60 Hz
Manual operation	Declutch mechanism
Mounting	Direct Coupled
Maximum Noise Rating, Driving (dBA @ 1m)	40
Rotation to Open	By switch
Compatible Damper Shafts	3/8 to 1.06 in. round or 3/8 to 11/16 in. square (10 to 27 mm round or 10 to 18 mm square)
Shaft Adapter Type	Self-centering clamping
Materials	Plenum rated plastic housing
Operating Humidity Range (% RH)	5 to 95% RH, non-condensing
Ambient Temperature Range	-5 F to +140 F (-20 C to +60 C)
Storage Temperature Range	-40 F to +175 F (-40 C to +80 C)
Weight	3.2 lb (1.45 kg)
Includes	Mounting bracket, self-centering shaft adapter
Comments	Integral 1/2 in. NPSM conduit connection.

APPROVALS

CE	89/336/ECC, 73/23/EEC
C-Tick	N314
Underwriters Laboratories, Inc.	UL873, Plenum Rated
Canadian Underwriters Laboratories, Inc.	cUL C22.2 No. 24-93

DIMENSIONS DIAGRAM

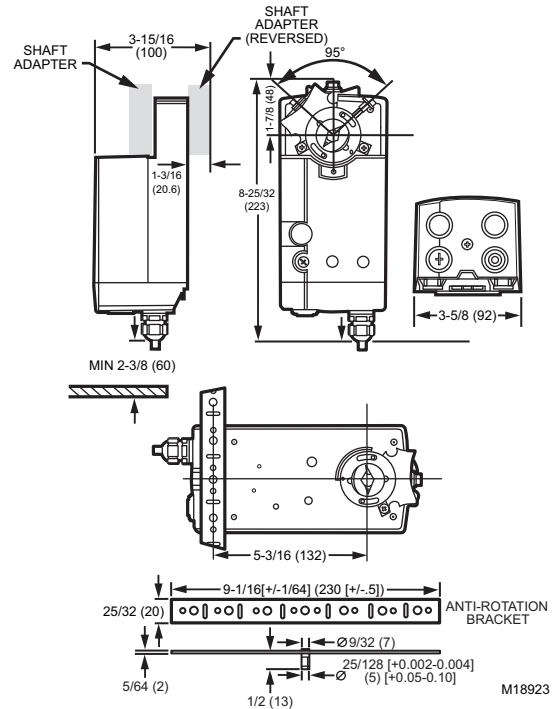

Submittal Data - Actuators

Spring Return MS4104F, MS4604F, MS8104F



Fire and Smoke Damper Actuator

Spring return direct coupled actuators (DCA) for on/off damper control. The actuator accepts an on/off signal from a single-pole, singlethrow (SPST) controller. They are designed to operate reliably in smoke control systems requiring Underwriters Laboratories Inc. UL555S ratings up to 350 F.

SPECIFICATIONS

Actuator Type	Damper
Rotational Stroke	95 +/- 3 degrees
Fail Safe Mode	Spring Return
Torque	30 lb-in. (3.4 Nm)
Minimum Driving Torque at 350 F	30 lb-in.
Spring Return Torque	30 lb-in. (3.4 Nm)
Number of Internal Auxiliary Switches:	2
Electrical Connections	Color-coded leads
Electrical Connection Length	32 in. (0.8 m)
Environmental Rating	NEMA 1, IP40
Frequency	60 Hz
Mounting	Direct Coupled
Maximum Noise Rating, Holding (dBA @ 1m) ..	20 (no audible noise)
Maximum Noise Rating, Driving (dBA @ 1m) ..	80
Compatible Damper Shafts	3/8 to 1/2 in. round (10 to 13 mm square/round)
Shaft Adapter Type	Aluminum Hub, two set screws
Materials	Aluminum housing
Operating Humidity Range (% RH)	5 to 95% RH, non-condensing
Ambient Temperature Range	0 F to +130 F (-18 C to +55 C)
Storage Temperature Range	-40 F to 140 F (-40 C to +60 C)
Weight	5 lb (2.27 kg)
Comments	Two integral 3/8 in. clip-in flexible conduit connections

APPROVALS

CE	89/336/ECC, 73/23/EEC
C-Tick	N314
Underwriters Laboratories, Inc	UL873, Plenum Rated
Canadian Underwriters Laboratories, Inc.	cUL C22.2 No. 24-93

FEATURES

- Reversible mounting facilitates use in either clockwise (cw) or counterclockwise (ccw) spring rotation.
- Integral spring return ensures level of return torque.
- Fifteen-second spring return timing.
- No special cycling required during long-term holding. (See Operation section.)
- No audible noise during holding.
- Patent pending design eliminates need for limit switches to reduce power consumption.
- Models available for 24, 120, and 230 Vac.
- Ninety-five degree angle of rotation.
- Actuator holds rated torque at reduced power level.
- Die-cast aluminum housing.
- Housing design allows flush mounting to damper.
- Designed to operate reliably in smoke control systems requiring Underwriters Laboratories Inc. UL555S ratings up to 350°F.
- Models available with SPST position-indicating switches (7°, 85° stroke).

DIMENSIONS DIAGRAM

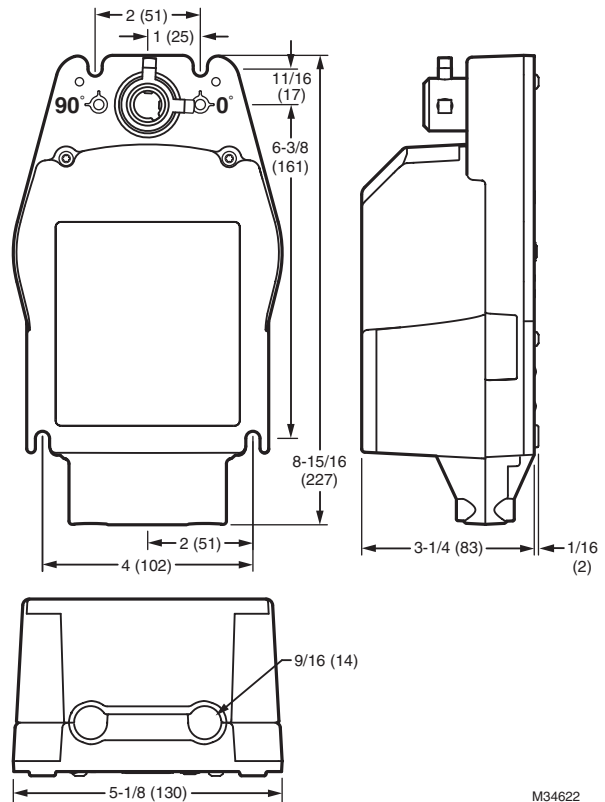

M34622



Fire and Smoke Damper Actuator

Spring return direct coupled actuators (DCA) for on/off damper control. The actuator accepts an on/off signal from a single-pole, singlethrow (SPST) controller. They are designed to operate reliably in smoke control systems requiring Underwriters Laboratories Inc. UL555S ratings up to 350 F.

FEATURES

- Reversible mounting facilitates use in either clockwise (cw) or counterclockwise (ccw) spring rotation.
- Integral spring return ensures level of return torque.
- Fifteen-second spring return timing.
- No special cycling required during long-term holding. (See Operation section.)
- No audible noise during holding.
- Patent pending design eliminates need for limit switches to reduce power consumption.
- Models available for 24, 120, and 230 Vac.
- Ninety-five degree angle of rotation.
- Actuator holds rated torque at reduced power level.
- Die-cast aluminum housing.
- Housing design allows flush mounting to damper.
- Designed to operate reliably in smoke control systems requiring Underwriters Laboratories Inc. UL555S ratings up to 350°F.
- Models available with SPST position indicating switches (7°, 85° stroke).

SPECIFICATIONS

Actuator Type	Damper
Rotational Stroke	95 +/- 3 degrees
Fail Safe Mode	Spring Return
Torque	80 lb-in. (9 Nm)
Minimum Driving Torque at 350 F	80 lb-in.
Spring Return Torque	80 lb-in. (9 Nm)
Number of Internal Auxiliary Switches:	2
Environmental Rating	NEMA 1, IP40
Frequency	60 Hz
Mounting	Direct Coupled
Maximum Noise Rating, Holding (dBA @ 1m)	20 (no audible noise)
Maximum Noise Rating, Driving (dBA @ 1m)	80
Compatible Damper Shafts	3/8 to 1/2 in. round (10 to 13 mm square/round)
Shaft Adapter Type	Aluminum Hub, four set screws
Supply Voltage	120 Vac +10%, -15%
Materials	Aluminum housing
Operating Humidity Range (% RH)	5 to 95% RH, non-condensing
Ambient Temperature Range	0 F to +130 F (-18 C to +55 C)
Storage Temperature Range	-40 F to 140 F (-40 C to +60 C)
Weight	5 lb (2.27 kg)
Comments	Two integral 3/8 in. clip-in flexible conduit connections

APPROVALS

CE	89/336/ECC, 73/23/EEC
C-Tick	N314
Underwriters Laboratories, Inc	UL873, Plenum Rated
Canadian Underwriters Laboratories, Inc.	cUL C22.2 No. 24-93

DIMENSIONS DIAGRAM

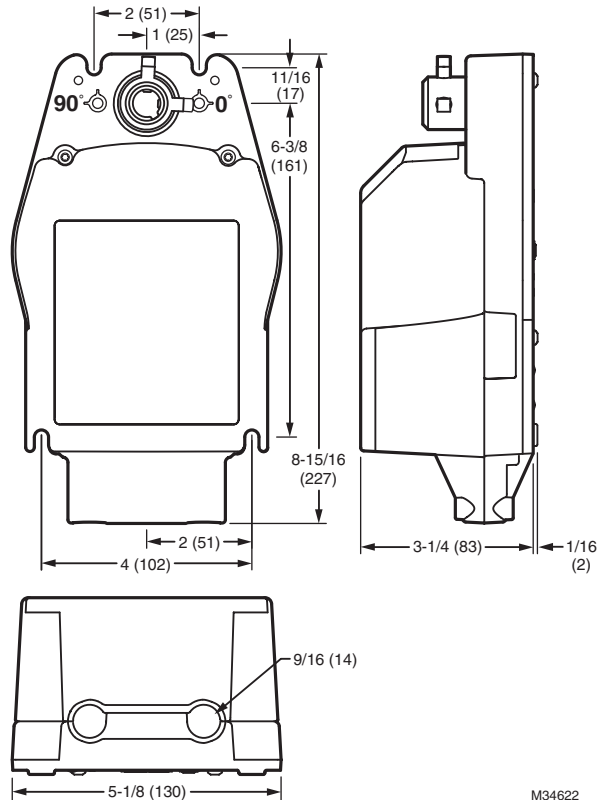

M34622

Submittal Data - Actuators

Spring Return MS4120F; MS4620F; MS8120F



Fire and Smoke Damper Actuator

Spring return direct coupled actuators (DCA) for on/off damper control with an integral junction box. The actuator accepts an on/off signal from a single-pole, single-throw (SPST) controller. They are designed to operate reliably in smoke control systems requiring Underwriters Laboratories Inc. UL555S ratings up to 350 F.

FEATURES

- Brush DC submotor with electronic stall protection for 2-position models
- Self-centering shaft adapter (shaft coupling) for wide range of shaft sizes
- Models available for use with two-position, single pole single throw (spst), line- (Series 40) or low- (Series 80) voltage controls
- Metal housing with built-in mechanical end limits
- Spring return direction field-selectable
- Shaft position indicator and scale
- Manual winding capability with locking function
- UL (cUL) listed and CE compliant
- All models are plenum-rated per UL873

SPECIFICATIONS

Actuator Type	Damper
Rotational Stroke	95 ±3 degrees
Fail Safe Mode	Spring Return
Torque	175 lb-in. (20 Nm)
Minimum Driving Torque at 350 F	175 lb-in.
Spring Return Torque	175 lb-in. (20 Nm)
Spring Return Direction:	By orientation
External Auxiliary Switches Available... No	
Electrical Connections	Teflon-jacketed cable
Electrical Connection Length	40 in. (1 m)
Environmental Rating	NEMA2
Ingress Protection Rating	IP54
Frequency	60 Hz
Manual operation	Manual crank
Mounting	Direct Coupled
Maximum Noise Rating, Holding (dBA @ 1m)	20 (no audible noise)
Maximum Noise Rating, Driving (dBA @ 1m)	70
Compatible Damper Shafts	3/8 to 1.06 in. round or 3/8 to 1 1/16 in. square (10 to 27 mm round or 10 to 18 mm square)
Shaft Adapter Type	Self-centering clamping
Supply Voltage	120 Vac ±10%
Materials	Aluminum housing
Operating Humidity Range (% RH)	5 to 95% RH, non-condensing
Ambient Temperature Range	-40 F to +130 F (-40 C to +55 C)
Storage Temperature Range	-40 F to +140 F (-40 C to +60 C)
Weight	8 lb (3.63 kg)
Includes	Self-centering shaft adapter, 3mm crank
Comments	Two integral 3/8 in. flexible conduit connections

APPROVALS

CE	89/336/ECC, 73/23/EEC
C-Tick	N314
Underwriters Laboratories, Inc.	UL873, Plenum Rated
Canadian Underwriters Laboratories, Inc.	cUL C22.2 No. 24-93

DIMENSIONS DIAGRAM

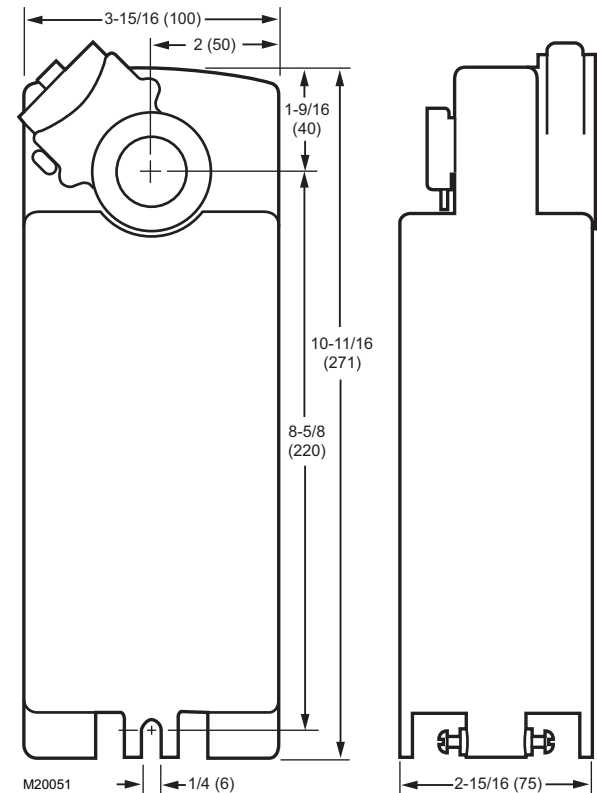

Wiring Diagrams - Actuators

Diamond 3 Nm (MS7103, MS7503)

Wiring for SPDT on/off control, MS75.

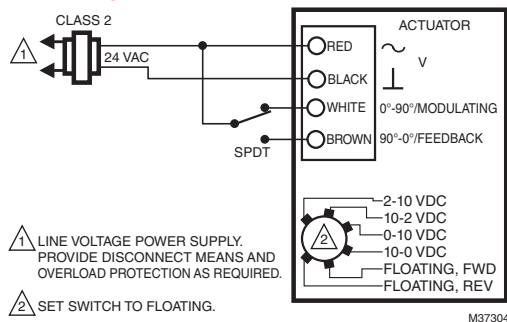

Wiring for floating control, MS75.

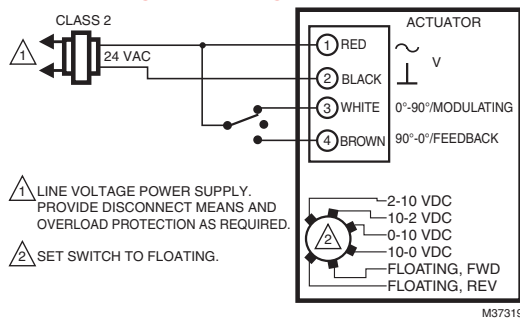

Wiring for modulating (0/2-10 VDC) proportioning control, MS75 (shown) and MS71.

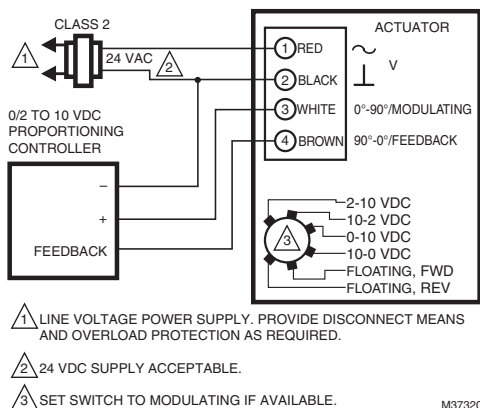

Wiring for 4-20 mA proportioning controllers, MS75 (shown) and MS71.

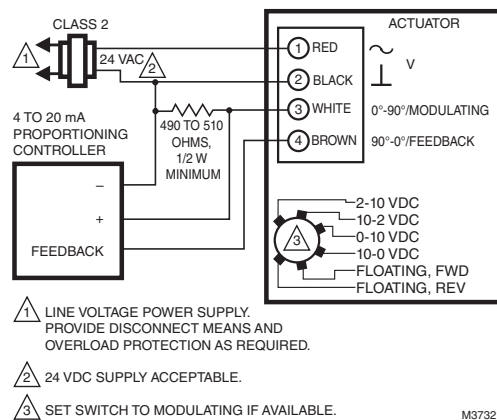

Wiring for modulating (0/2-10 VDC) proportioning control operating multiple actuators, MS75 (shown) and MS71.

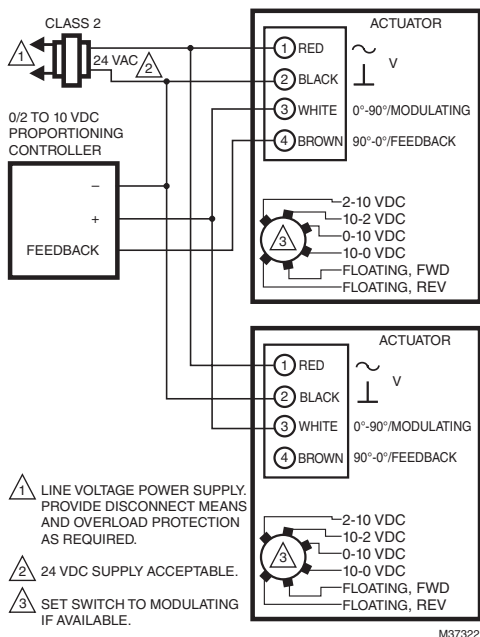

Override to open position

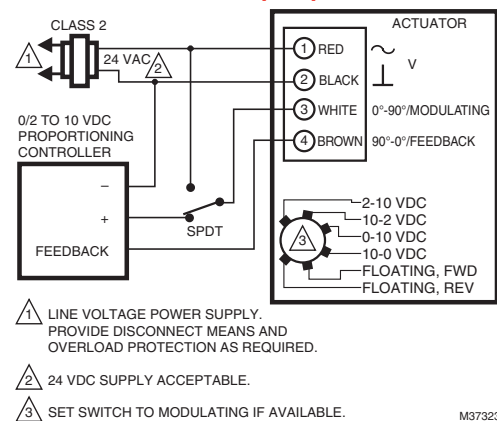

Return to closed position.

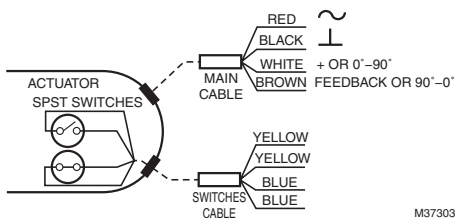

Cable installation details.

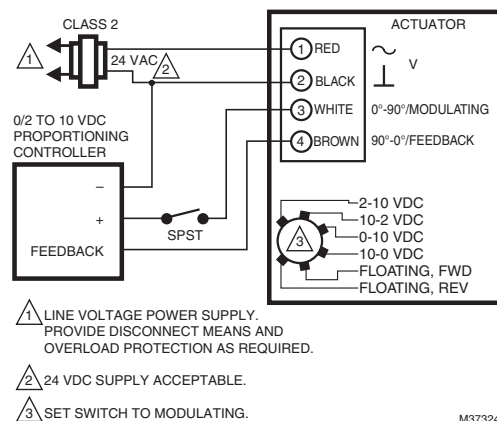

Wiring Diagrams - Actuators

Spring Return S03 and S05 Series

S03 Series (MS4103, MS7403, MS7403, MS7503, MS8103) and S05 Series (MS4105, MS7105, MS7405, MS7505, MS8105)

Wiring for low-voltage two-position control

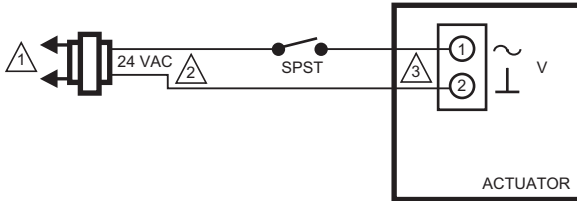

- 1 LINE VOLTAGE POWER SUPPLY. PROVIDE DISCONNECT MEANS AND OVERLOAD PROTECTION AS REQUIRED.
- 2 24 VDC SUPPLY ACCEPTABLE.
- 3 ENSURE PROPER GROUNDING OF ACTUATOR CASE.

M19718C

Wiring for line-voltage two-position control

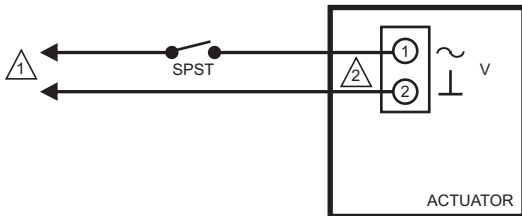

- 1 LINE VOLTAGE POWER SUPPLY. PROVIDE DISCONNECT MEANS AND OVERLOAD PROTECTION AS REQUIRED.
- 2 ENSURE PROPER GROUNDING OF ACTUATOR CASE.

M22289A

Wiring for SPDT on/off Control

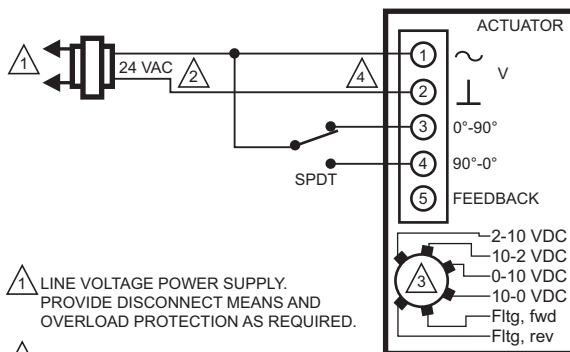

- 1 LINE VOLTAGE POWER SUPPLY. PROVIDE DISCONNECT MEANS AND OVERLOAD PROTECTION AS REQUIRED.
- 2 24 VDC SUPPLY ACCEPTABLE.
- 3 SET SWITCH TO FLOATING.
- 4 ENSURE PROPER GROUNDING OF ACTUATOR CASE.

M27822

Wiring for floating control

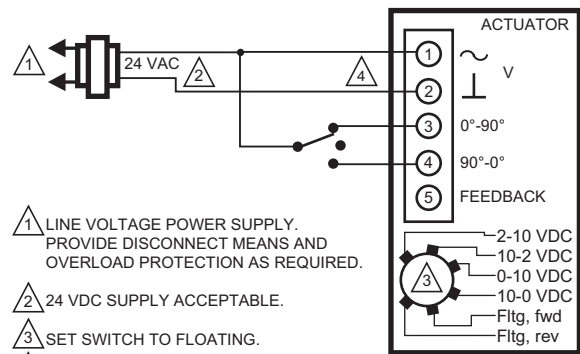

- 1 LINE VOLTAGE POWER SUPPLY. PROVIDE DISCONNECT MEANS AND OVERLOAD PROTECTION AS REQUIRED.
- 2 24 VDC SUPPLY ACCEPTABLE.
- 3 SET SWITCH TO FLOATING.
- 4 ENSURE PROPER GROUNDING OF ACTUATOR CASE.

M27823

Wiring for (0)2-10 VDC proportioning controllers

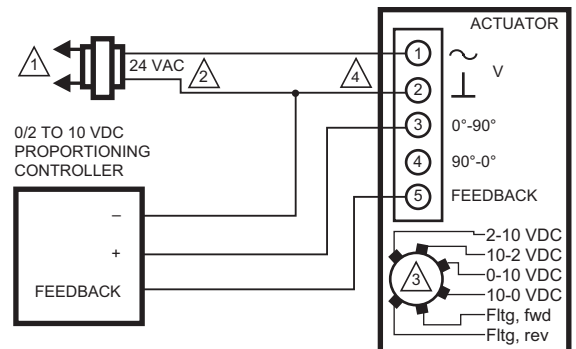

- 1 LINE VOLTAGE POWER SUPPLY. PROVIDE DISCONNECT MEANS AND OVERLOAD PROTECTION AS REQUIRED.
- 2 24 VDC SUPPLY ACCEPTABLE.
- 3 SET SWITCH TO MODULATING.
- 4 ENSURE PROPER GROUNDING OF ACTUATOR CASE.

M27824

Wiring for 4-20 mA proportioning controllers

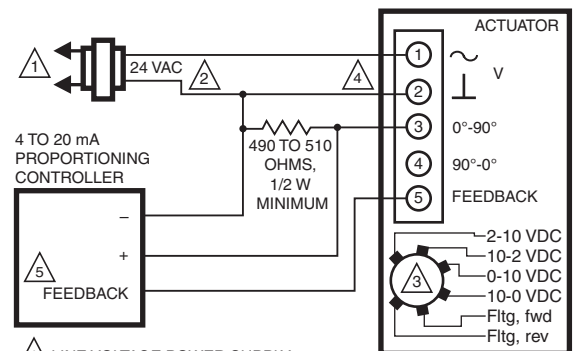

- 1 LINE VOLTAGE POWER SUPPLY. PROVIDE DISCONNECT MEANS AND OVERLOAD PROTECTION AS REQUIRED.
- 2 24 VDC SUPPLY ACCEPTABLE.
- 3 SET SWITCH TO MODULATING.
- 4 ENSURE PROPER GROUNDING OF ACTUATOR CASE.
- 5 FEEDBACK WILL BE A 2-10 VDC.

M27825A

Wiring Diagrams - Actuators

Spring Return S03 and S05 Series

ACTUATORS

Wiring for (0)2-10 Vdc proportioning controller operating multiple actuators

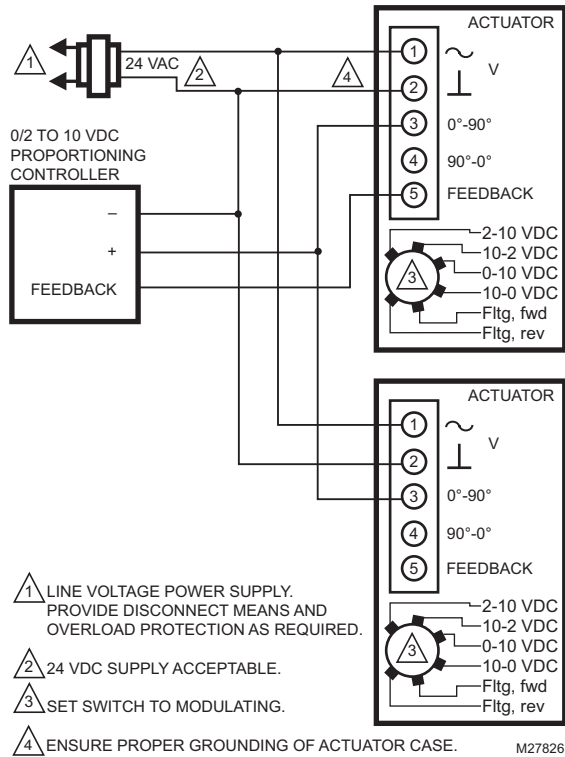

Wiring for 3 kOhm Economizer controllers

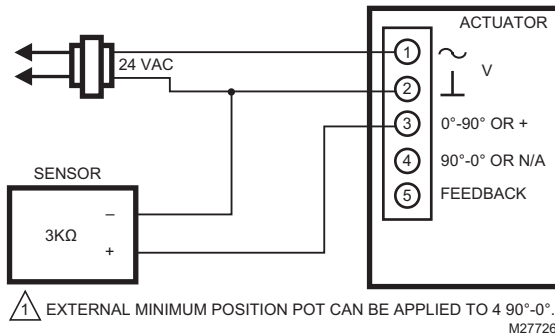

Wiring for 3 position Economizer controllers

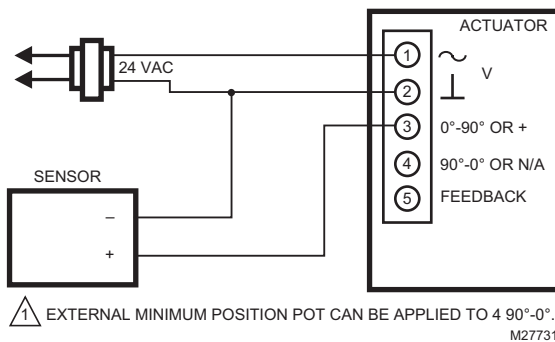

Override to full open

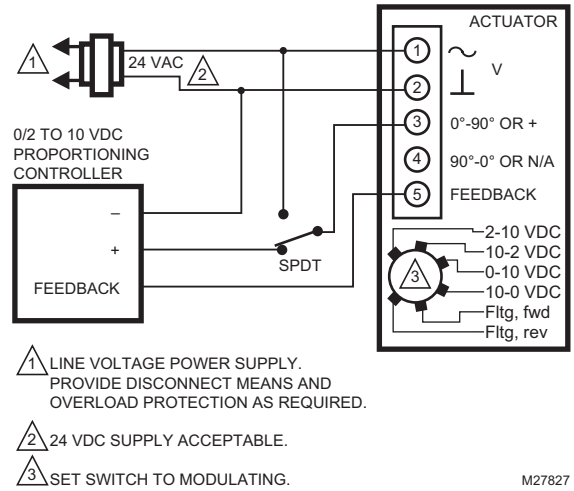

Override to full close

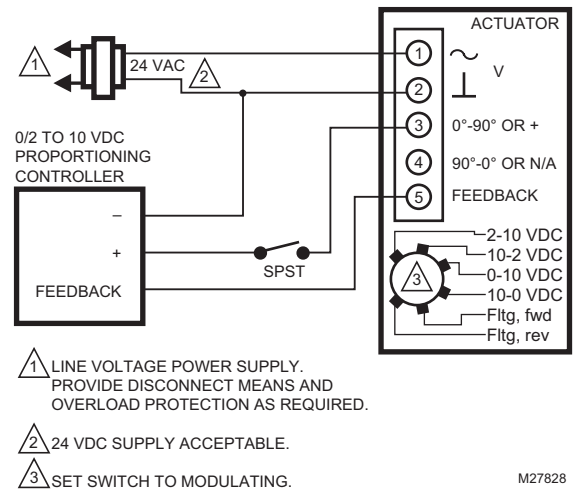

Wiring Diagrams - Actuators

Spring Return S10 and S20 Series

S10 Series (MS4110, MS7510, MS8110) and S20 Series (MS4120, MS7520, MS8120)

Wiring for On/Off Control

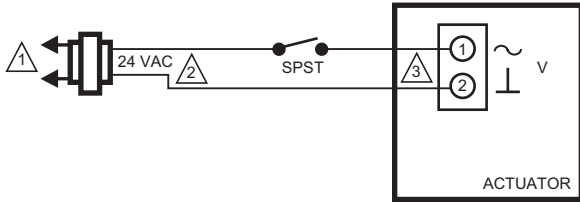

- 1 LINE VOLTAGE POWER SUPPLY. PROVIDE DISCONNECT MEANS AND OVERLOAD PROTECTION AS REQUIRED.
- 2 24 VDC SUPPLY ACCEPTABLE.
- 3 ENSURE PROPER GROUNDING OF ACTUATOR CASE.

M19718C

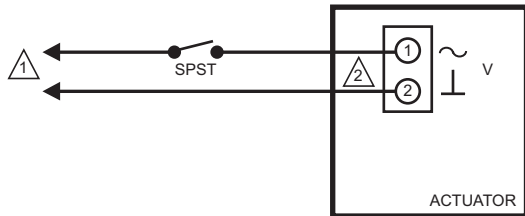

- 1 LINE VOLTAGE POWER SUPPLY. PROVIDE DISCONNECT MEANS AND OVERLOAD PROTECTION AS REQUIRED.
- 2 ENSURE PROPER GROUNDING OF ACTUATOR CASE.

M22289A

Wiring for Floating Control (Floating mode setting)

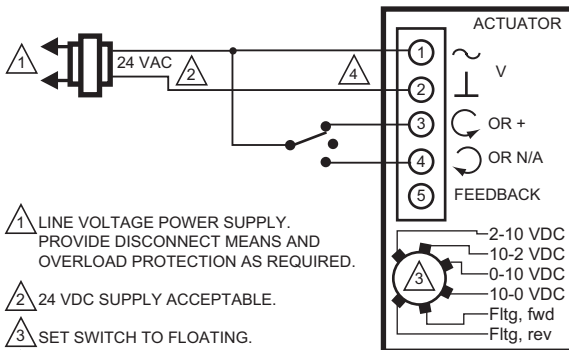

- 1 LINE VOLTAGE POWER SUPPLY. PROVIDE DISCONNECT MEANS AND OVERLOAD PROTECTION AS REQUIRED.
- 2 24 VDC SUPPLY ACCEPTABLE.
- 3 SET SWITCH TO FLOATING.
- 4 ENSURE PROPER GROUNDING OF ACTUATOR CASE.

M19573B

Wiring for Proportioning controllers (Modulating mode setting)

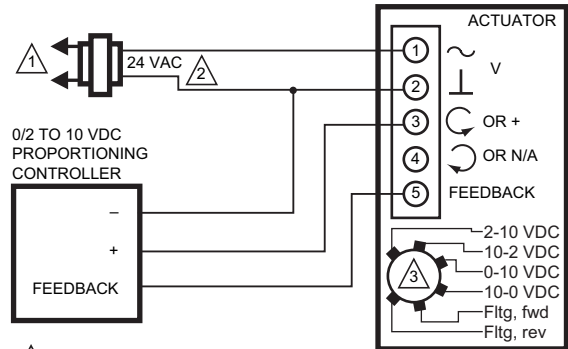

- 1 LINE VOLTAGE POWER SUPPLY. PROVIDE DISCONNECT MEANS AND OVERLOAD PROTECTION AS REQUIRED.
- 2 24 VDC SUPPLY ACCEPTABLE.
- 3 SET SWITCH TO MODULATING.

M19574A

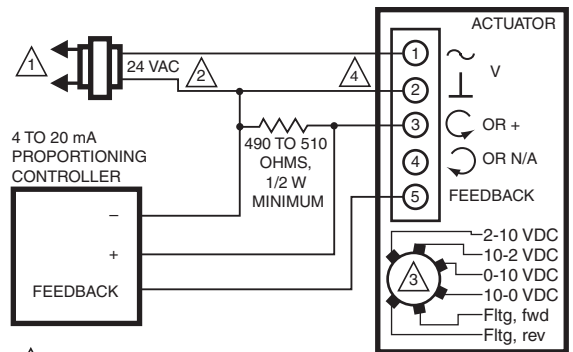

- 1 LINE VOLTAGE POWER SUPPLY. PROVIDE DISCONNECT MEANS AND OVERLOAD PROTECTION AS REQUIRED.
- 2 24 VDC SUPPLY ACCEPTABLE.
- 3 SET SWITCH TO MODULATING.
- 4 ENSURE PROPER GROUNDING OF ACTUATOR CASE.
- 5 FEEDBACK WILL BE A 2-10 VDC.

M22282C

Wiring Diagrams - Actuators

Spring Return S10 and S20 Series

Override to full open (Modulating mode setting)

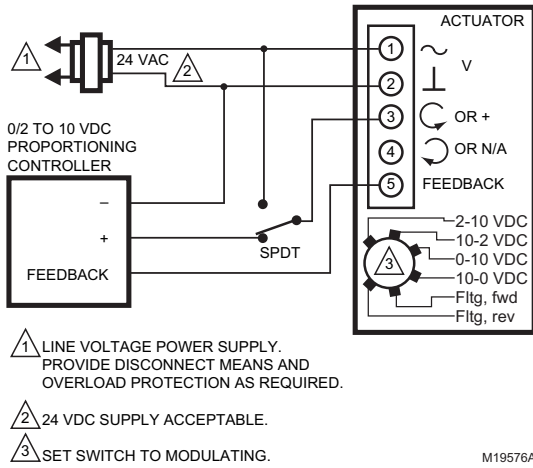

Override to full closed (Modulating mode setting)

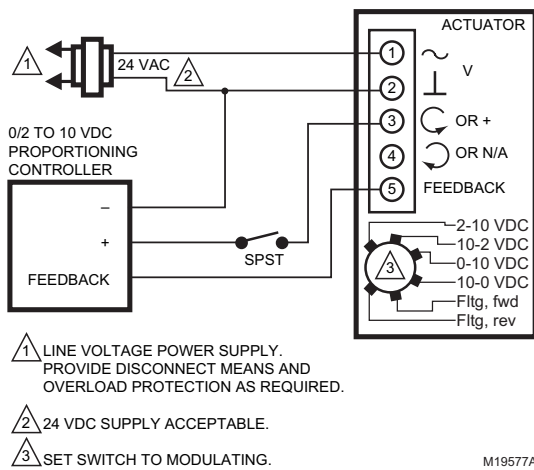

Wiring for Proportioning controllers operating multiple actuators (Modulating mode setting)

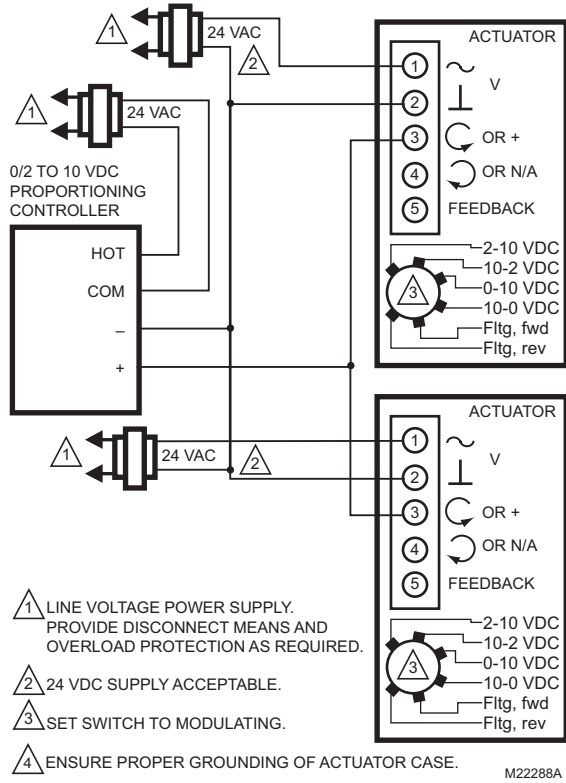

Terminal Block Details

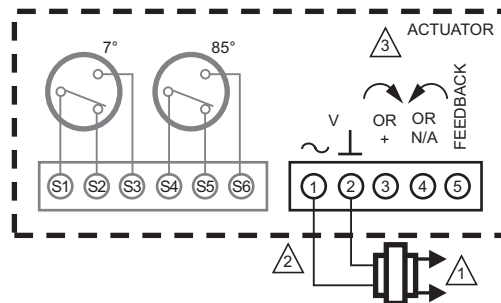

Wiring Diagrams - Actuators

Non-spring Return ML6161; ML7161

ML6161 and ML7161

ML7161 used with 4-20 mA control

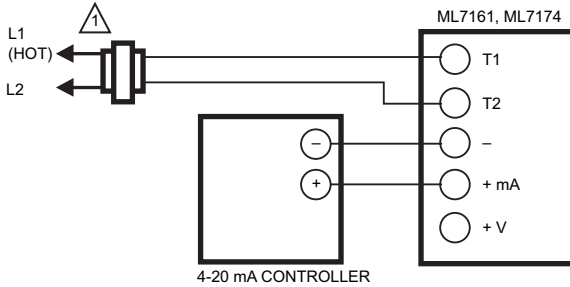

⚠ POWER SUPPLY. PROVIDE DISCONNECT MEANS AND OVERLOAD PROTECTION AS REQUIRED.

M18071

ML7161 used with 2-10 Vdc control

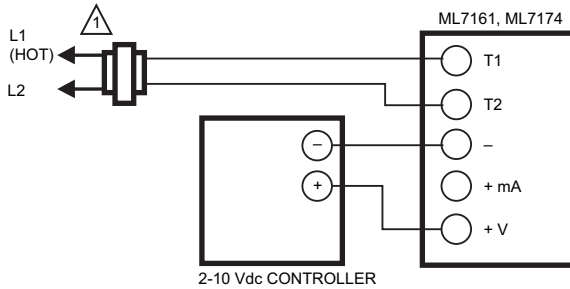

⚠ POWER SUPPLY. PROVIDE DISCONNECT MEANS AND OVERLOAD PROTECTION AS REQUIRED.

M18072

ML6174 and ML7174

ML7174 used with 4-20 mA control

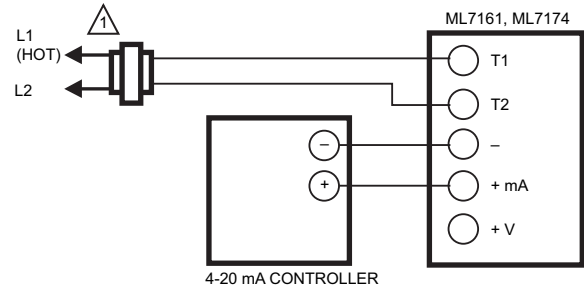

⚠ POWER SUPPLY. PROVIDE DISCONNECT MEANS AND OVERLOAD PROTECTION AS REQUIRED.

M18071

ML7174 used with 2-10 Vdc control

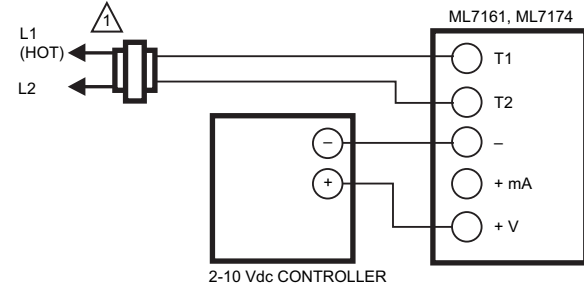

⚠ POWER SUPPLY. PROVIDE DISCONNECT MEANS AND OVERLOAD PROTECTION AS REQUIRED.

M18072

Wiring Diagrams - Actuators

Non-spring Return N05 and N10 Series

N05 Series (MN6105, MN7505) and N10 Series (MN6110, MN7510)

Wiring for Floating Control

MN6105, MN6110
FLOATING: DIR ↺

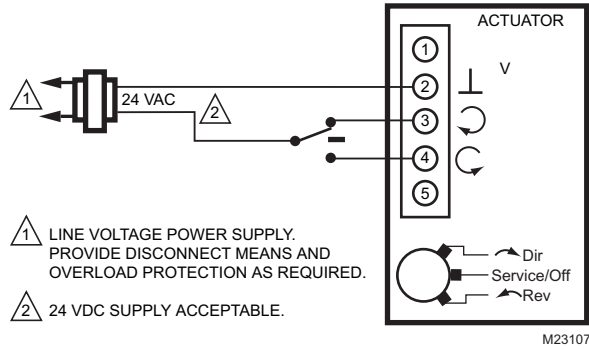

Wiring for Voltage Control

MN7505, MN7510
MODULATING: 0[2]... 10 V, 10... 0[2] V

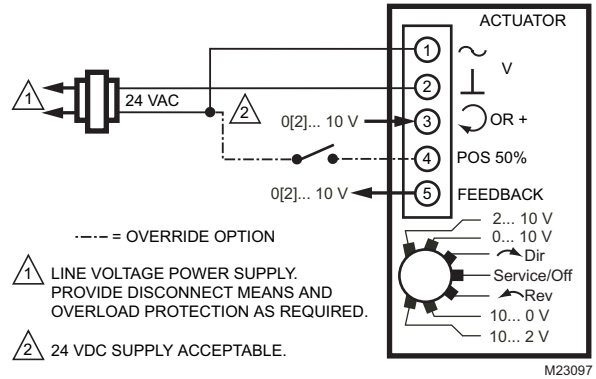

Wiring for Auxiliary Switches

END SWITCHES (CLASS II-ONLY)

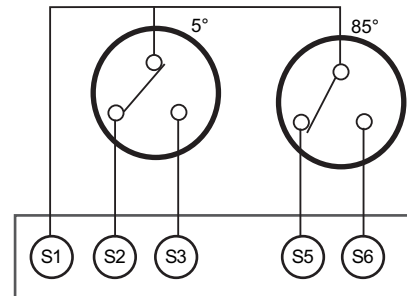

Wiring Diagrams - Actuators

Non-spring Return N20 and N34 Series

N20 Series (MN6120, MN7220) and N34 Series (MN6134, MN7234)

Used for On/Off Control

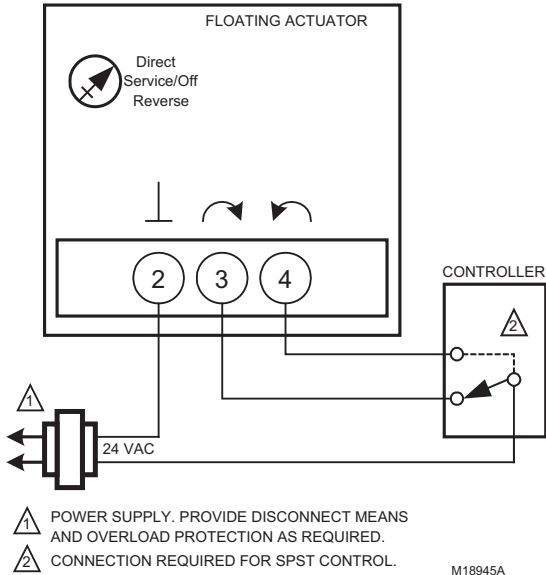

Wiring for Floating Control

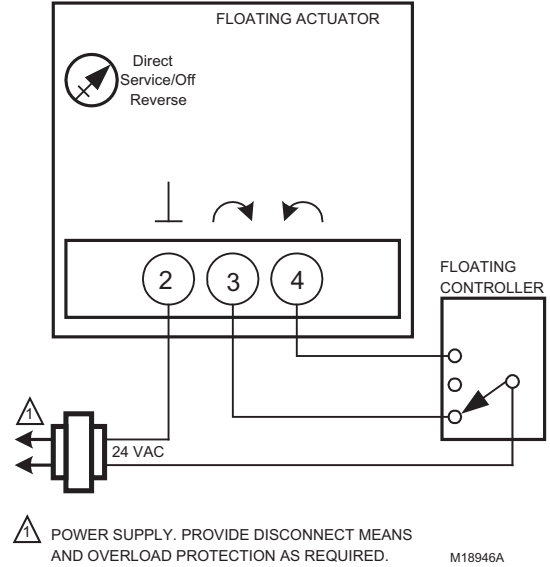

Wiring for Modulating Control

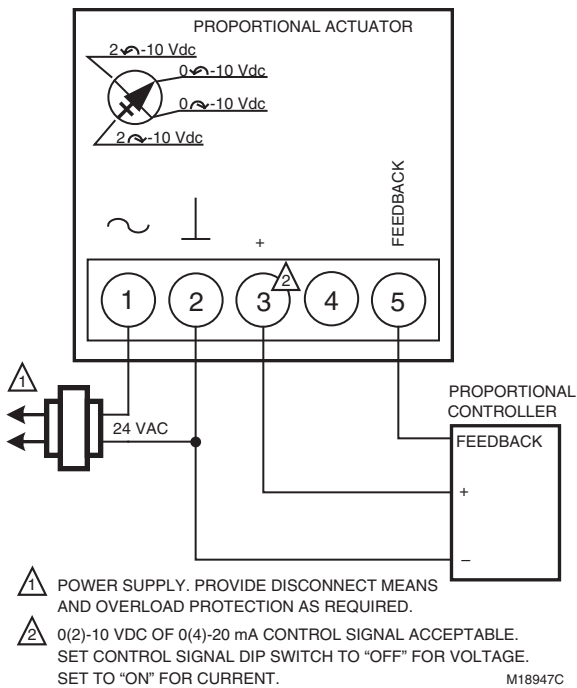

Wiring for Auxiliary Switches

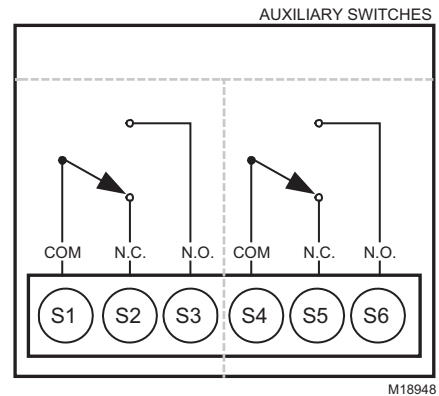

Wiring Diagrams - Actuators

Fire and Smoke Damper Actuators

MS4209F, MS4309F, MS4709F, MS4809F, MS8209F and MS8309F

Typical 24 Vac wiring

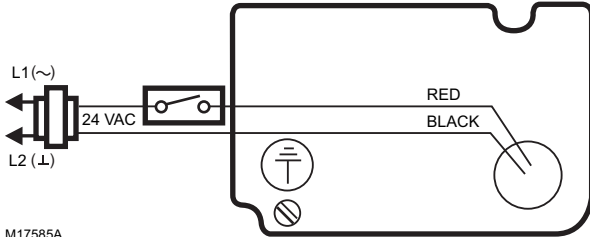

M17585A

Typical 230 Vac Wiring

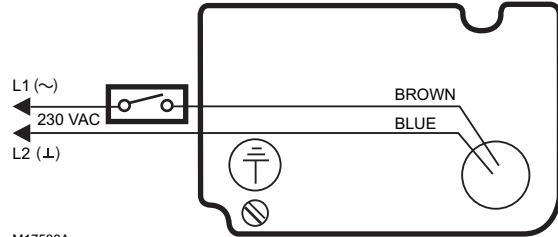

M17588A

Typical 120 Vac wiring

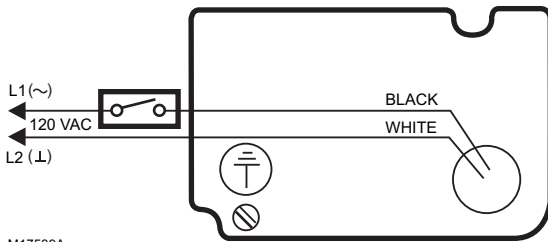

M17589A

MS4120F, MS4620F, MS8120F, MS4109F, MS4609F and MS8109F

Wiring for 24V Control

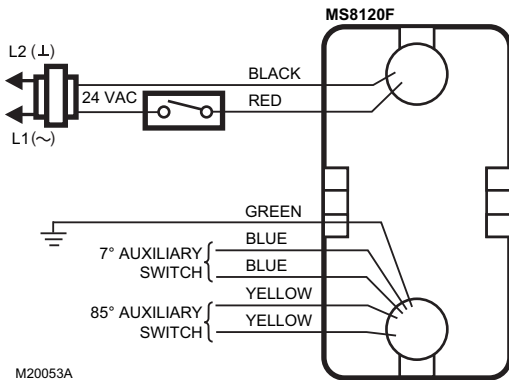

M20053A

Wiring for 120V Control

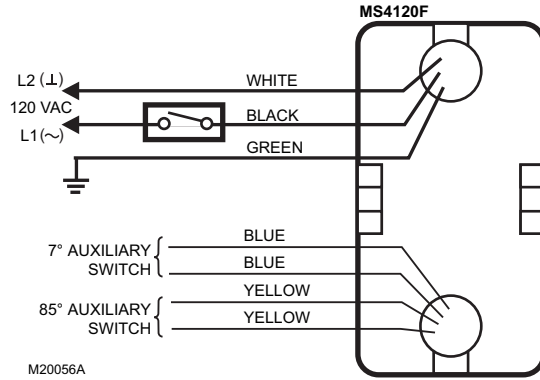

M20056A

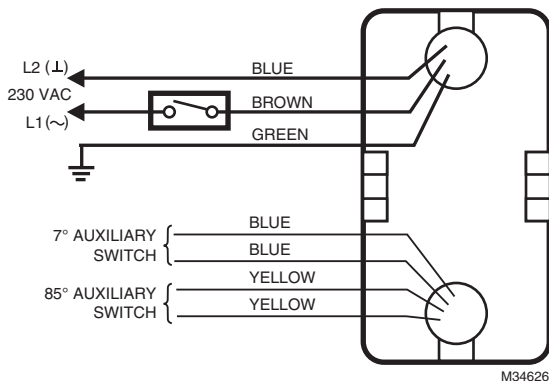

Wiring for 230V Control





M34626

Accessories - Actuators

Ball Joints, Push Rod Accessories

	Product Number	Description	Used With
	27518	Crankarm balljoint with 1/4 - 28 UNF male threads, fits 5-16 inch diameter push rods	All Actuators and Dampers
	27520A	Push Rod (5/16 in. dia., 5 in. length)	All Actuators and Dampers
	27520B	Push Rod (5/16 in. dia., 10 in. length)	All Actuators and Dampers
	27520C	Push Rod (5/16 in. dia., 12 in. length)	All Actuators and Dampers
	27520D	Push Rod (5/16 in. dia., 15 in. length)	All Actuators and Dampers
	27520E	Push Rod (5/16 in. dia., 18 in. length)	All Actuators and Dampers
	27520G	Push Rod (5/16 in. dia., 24 in. length)	All Actuators and Dampers
	27520H	Push Rod (5/16 in. dia., 28 in. length)	All Actuators and Dampers
	27520K	Push Rod (5/16 in. dia., 36 in. length)	All Actuators and Dampers
	27520L	Push Rod (5/16 in. dia., 48 in. length)	All Actuators and Dampers
	27520Q	Push Rod (5/16 in. dia., 8 in. length)	All Actuators and Dampers



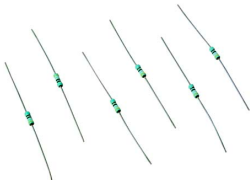

Control, Positioning, Feedback Accessories

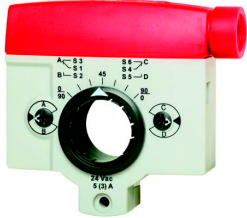
	Product Number	Description	Used With
	200976A	Auxiliary Feedback Potentiometer (0 to 500 ohm)	ML6161, ML6174, ML7161, ML7174
	200976C	Auxiliary Feedback Potentiometer (0 to 2000 ohm)	ML6161, ML6174, ML7161, ML7174
	205860	Electronic Remote Minimum Position Potentiometer	Proportional Actuators
	32003532-005	High Temperature Dual Switch Assembly	ML4105, ML8105, ML4115, ML8115, ML4125, ML8125, ML4135, ML8135, MS4209, MS4309, MS4709, MS4809, MS8209, MS8309
	32006306-001	Resistor Kit (500 ohm, converts 4-20mA to 2-10Vdc)	Proportional Actuators

Control, Positioning, Feedback Accessories (cont.)

	Product Number	Description	Used With
	SW2-US	Auxiliary Switch Package (2 adjustable SPDT switches)	MS and MN Series High Torque Actuators (MNXX20 and XX34)

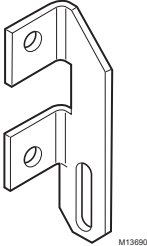
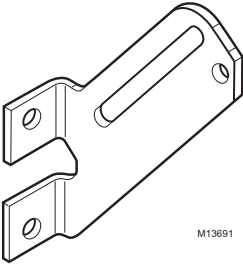
Mounting Accessories

	Product Number	Description	Used With
	205649	Mounting Bracket	ML41x5, ML81x5, MSxx04F, MSxx09F and MSxx20F Actuators
	32007205-001	Direct Coupled Actuator Mounting Bracket	Damper with External Actuator Mounting (i.e., 32007205-005 Kit)
	32007205-002	Damper Blade Drive Lever (Small)	All Actuators and Dampers
	32007205-003	Damper Blade Drive Lever (Large)	All Actuators and Dampers
	32007205-004	Retaining Clip, Damper External Drive Pin	Damper with External Actuator Mounting (i.e., 32007205-005 Kit)

Accessories - Actuators

Mounting Accessories (cont.)

	Product Number	Description	Used With
	32007205-005	Damper External Drive Pin Kit	Damper with External Actuator Mounting
	32007205-006	Damper Axle Coupling	Multi-Section Dampers
	32007205-007	Jumper Bracket	Multi-Section Dampers
	50000407-001	Actuator Tandem Mounting Kit	N20, N34 Actuators; S10, S20 Actuators
	50001194-001	Foot Mounting Kit	MS and MN Series High Torque Actuators (MNXX20 and MNXX34) MSxx10 and MSxx20, but not for MSxx20F
	50006427-001	Flexible Anti-Rotation Bracket	N20, N34 Actuators; S10, S20 Actuators
	STRN-BRKT	Anti-rotation Bracket for S03 and S05 Series Actuators	S03, S05 Actuator

Mounting Accessories (cont.)

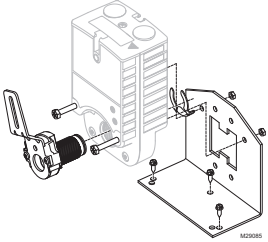
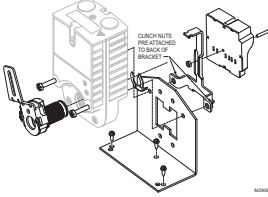
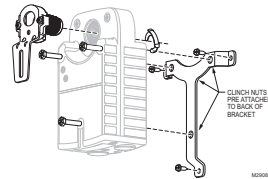

	Product Number	Description	Used With
	STRN-CRK-01	Crank arm kit for S03 and S05 Series Actuators	S03, S05 Actuators (not for use with Diamond actuators)
	STRN-ECONO-01	Economizer Retrofit Kit for S03 and S05 Series Actuators	S03, S05 Actuators (not for use with Diamond actuators)
	STRN-WMK-01	Wall mount kit for S03 and S05 Series Actuators	S03, S05 Actuators (not for use with Diamond actuators)

Rotational Limiters, Position Indicators



	Product Number	Description	Used With
	4074ENJ	Minimum Position Kit	ML6161, ML6174, ML7161, ML7174

Accessories - Actuators

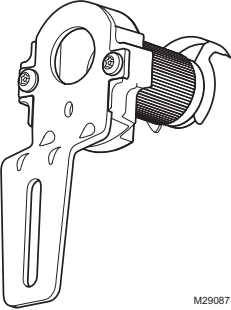
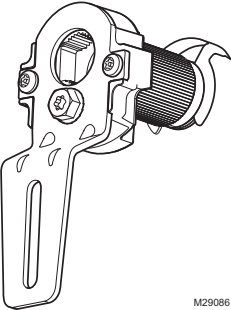

Crankarms

	Product Number	Description	Used With
	205830A	Rotary-to-Linear Kit Used With: 35 and 70 lb-in NSR Actuators	35 and 70 lb-in.NSR
	26026G	Damper Crank Arm, 1/2 in. damper shaft	All Actuators and Damper
 <small>M29087</small>	STRN-CA-01	Non Self-centering Crank Arm for S03 and S05 Series Actuators	S03, S05 Actuators (not for use with Diamond actuators)
 <small>M29086</small>	STRN-CA-02	Self-centering Crank Arm for S03 and S05 Series Actuators	S03; S05 Actuators (not for use with Diamond actuators)

Shaft Adapter Accessories

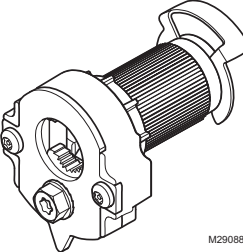

	Product Number	Description	Used With
	32003167-001	3/8 in. Shaft Adapter	ML6161; ML6174; ML7161; ML7174; ML7999
	32003168-001	Short Shaft Adapter (3/4 in. to 1/2 in.)	All Actuators and Dampers
	32003168-002	Short Shaft Adapter (5/8 in. to 1/2 in.)	All Actuators and Dampers
	32003168-003	Short Shaft Adapter (9/16 in. to 1/2 in.)	All Actuators and Dampers
	32003168-004	Short Shaft Adapter (1/2 in.)	All Actuators and Dampers

Shaft Adapter Accessories (cont.)

	Product Number	Description	Used With
	32004254-001	Self-Centering Shaft Adapter	N20 Actuators
	32004254-002	Self-Centering Shaft Adapter	S10, S20 Actuators
	172092060	Self-Centering Shaft Adapter	N34 Actuators
	4074ENY	3/8 in. Shaft Kit	ML6161, ML6174, ML7161, ML7174
	4074EVK	Short Shaft Kit	ML6161, ML6174, ML7161, ML7174
 <p>M29088</p>	STRN-SCSA	Self-centering Shaft Adapter	S03, S05 Actuators (not for use with Diamond actuators)

Accessories - Actuators



Enclosure Accessories

	Product Number	Description	Used With
	32003036-001	Weather Enclosure	All Actuators
	50005859-001	NEMA 4 Enclosure for Direct Coupled Actuator	ML6161, ML6174, ML7161, ML7174; 150 lb-in. NSR Actuators (ML Series); N20, N34 Actuators; S03, S05, S10, S20 Actuators
	7640QW	Enclosure for Conduit Connection	ML6161, ML6174, ML7161, ML7174

Q7002 Interface Modules

	Product Number	Description	Used With
	Q7002B1009	Transducer, Accepts dc voltage, current or resistive input and provides a voltage or current output	Direct Coupled Proportional Actuators and Modutrol Motors
	Q7002C1007	Transducer, Accepts a pulse-width modulation (PWM) signal and provides a voltage output	Direct Coupled Proportional Actuators and Modutrol Motors

Miscellaneous Accessories

	Product Number	Description	Used With
	32000085-001	Strain Relief Fitting 1/2" x 14 NPT	MS, MN and MVN Series Actuators
	STRN-STRNRLF	Strain Relief Fitting M20 x 1.5	MS and MN Series Actuators

Damper and Linkage Accessories

Product Number	Description	Used With
102546	Ball Joint, 5/16 in.	Damper Linkages
101662A/0021	Motor Mounting Bracket Assembly for Q605	Q605
102931/0021	Adapter arm for less than 90 degree rotation for the Q605	Q605
104643A	Adapter for driving 2 dampers from 1 crank arm	Kit Mounted Motors; Modutrol IV Motors
26025F	Damper Arm, 3/8 in. shaft	—
26026B	Damper Arm, 1/2 in. shaft, 3 in. long	—
7617ACL	Bag Assembly	Q605

Cross Reference - Actuators

Direct Coupled Actuators

Belimo Model	Fail Safe	Torque (lb-in)	Control Signal	Power	Feedback	Switches	Timing (sec)	Honeywell Model	Torque (lb-in)	Control Signal	Power	Feedback	Switches	Timing (sec)
CMB24-3	NSR	18 lb-in	On/Off, Floating	24 Vac/Vdc	—	—	35	ML6161A2009	35 lb-in	On/Off, Floating	24 Vac	—	—	90
CMB120-3	NSR	18 lb-in	On/Off, Floating	100-240 Vac	—	—	35	ML6161A2009	35 lb-in	On/Off, Floating	24 Vac	—	—	90
CMB24-SR-R	NSR	18 lb-in	2-10 Vdc (4-20 mA)	24 Vac/Vdc	2-10 Vdc	—	35	ML7161A2008	35 lb-in	On/Off, Floating	24 Vac	—	—	90
CMB24-SR-L	NSR	18 lb-in	2-10 Vdc (4-20 mA)	24 Vac/Vdc	2-10 Vdc	—	35	ML7161A2008	35 lb-in	On/Off, Floating	24 Vac	—	—	90
LMB24-3-P5-T	NSR	45 lb-in	On/Off, Floating	24 Vac/Vdc	0-5 kOhm	—	95	ML6174A2002 + 200976A	70 lb-in	On/Off, Floating	24 Vac	500 kOhm	—	90
								ML6174A2002 + 200976C	70 lb-in	On/Off, Floating	24 Vac	2 kOhm	—	90
LMB24-3-P10-T	NSR	45 lb-in	On/Off, Floating	24 Vac/Vdc	0-10 kOhm	—	95	ML6174A2002 + 200976A	70 lb-in	On/Off, Floating	24 Vac	500 kOhm	—	90
								ML6174A2002 + 200976C	—	On/Off, Floating	24 Vac	2 kOhm	—	90
LMB24-3	NSR	45 lb-in	On/Off, Floating	24 Vac/Vdc	—	—	95	MN6105A1011	44 lb-in	On/Off, Floating	24 Vac/Vdc	—	—	90
LMB24-3-T	NSR	45 lb-in	On/Off, Floating	24 Vac/Vdc	—	—	95	MN6105A1011	44 lb-in	On/Off, Floating	24 Vac/Vdc	—	—	90
LMB24-3-S	NSR	45 lb-in	On/Off, Floating	24 Vac/Vdc	—	1	95	MN6105A1201	44 lb-in	On/Off, Floating	24 Vac/Vdc	—	2	90
LMB24-SR	NSR	45 lb-in	2-10 Vdc (4-20 mA)	24 Vac/Vdc	2-10 Vdc	—	95	MN7505A2001	44 lb-in	On/Off, Floating, (0) 2-10 Vdc	24 Vac/Vdc	(0) 2-10 Vdc	—	90
LMX24-SR	NSR	45 lb-in	2-10 Vdc (4-20 mA)	24 Vac/Vdc	2-10 Vdc	—	95	MN7505A2001	44 lb-in	On/Off, Floating, (0) 2-10 Vdc	24 Vac/Vdc	(0) 2-10 Vdc	—	90
LMB24-SR-T	NSR	45 lb-in	2-10 Vdc (4-20 mA)	24 Vac/Vdc	—	—	95	MN7505A2001	44 lb-in	On/Off, Floating, (0) 2-10 Vdc	24 Vac/Vdc	(0) 2-10 Vdc	—	90
LMX24-SR-T	NSR	45 lb-in	2-10 Vdc (4-20 mA)	24 Vac/Vdc	—	—	95	MN7505A2001	44 lb-in	On/Off, Floating, (0) 2-10 Vdc	24 Vac/Vdc	(0) 2-10 Vdc	—	90
LMB24-MFT	NSR	45 lb-in	MFT	24 Vac/Vdc	Variable (0-10 Vdc)	—	150	MN7505A2001	44 lb-in	On/Off, Floating, (0) 2-10 Vdc	24 Vac/Vdc	(0) 2-10 Vdc	—	90
LMX24-MFT	NSR	45 lb-in	MFT	24 Vac/Vdc	Variable (0-10 Vdc)	—	150	MN7505A2001	44 lb-in	On/Off, Floating, (0) 2-10 Vdc	24 Vac/Vdc	(0) 2-10 Vdc	—	90
LMX24-MFT	NSR	45 lb-in	MFT	24 Vac/Vdc	Variable (0-10 Vdc)	Add-On	150	MN7505A2209	44 lb-in	On/Off, Floating, (0) 2-10 Vdc	24 Vac/Vdc	(0) 2-10 Vdc	2	90
LMCB24-3	NSR	45 lb-in	On/Off, Floating	24 Vac/Vdc	—	—	35	MN6105A1011	44 lb-in	On/Off, Floating	24 Vac/Vdc	—	—	90
LMCB24-3-T	NSR	45 lb-in	On/Off, Floating	24 Vac/Vdc	—	—	35	MN6105A1011	44 lb-in	On/Off, Floating	24 Vac/Vdc	—	—	90
LMX24-3	NSR	45 lb-in	On/Off, Floating	24 Vac/Vdc	—	—	95	MN6105A1011	44 lb-in	On/Off, Floating	24 Vac/Vdc	—	—	90
LMX24-3-T	NSR	45 lb-in	On/Off, Floating	24 Vac/Vdc	—	—	95	MN6105A1011	44 lb-in	On/Off, Floating	24 Vac/Vdc	—	—	90
LMCB24-SR	NSR	45 lb-in	2-10 Vdc (4-20 mA)	24 Vac/Vdc	2-10 Vdc	—	35	MN7505A2001	44 lb-in	On/Off, Floating, (0) 2-10 Vdc	24 Vac/Vdc	(0) 2-10 Vdc	—	90
LMCB24-SR-T	NSR	45 lb-in	2-10 Vdc (4-20 mA)	24 Vac/Vdc	—	—	35	MN7505A2001	44 lb-in	On/Off, Floating, (0) 2-10 Vdc	24 Vac/Vdc	(0) 2-10 Vdc	—	90
LMX120-SR	NSR	45 lb-in	2-10 Vdc (4-20 mA)	100-240 Vac	2-10 Vdc	—	95	MN7505A2001	44 lb-in	On/Off, Floating, (0) 2-10 Vdc	24 Vac/Vdc	(0) 2-10 Vdc	—	90
LMX120-3	NSR	45 lb-in	On/Off, Floating	100-240 Vac	—	—	150	MN6105A1011	44 lb-in	On/Off, Floating	24 Vac/Vdc	—	—	90
LMQX24-MFT	NSR	35 lb-in	MFT	24 Vac/Vdc	Variable (0-10 Vdc)	—	150	ML6161A2009	35 lb-in	On/Off, Floating, (0) 2-10 Vdc	24 Vac	—	—	90
NMB24-3	NSR	90 lb-in	On/Off, Floating	24 Vac/Vdc	—	—	95	MN6110A1003	88 lb-in	On/Off, Floating	24 Vac/Vdc	—	—	90
NMCB24-3	NSR	90 lb-in	On/Off, Floating	24 Vac/Vdc	—	—	45	MN6110A1003	88 lb-in	On/Off, Floating	24 Vac/Vdc	—	—	90
NMX24-3	NSR	90 lb-in	On/Off, Floating	24 Vac/Vdc	—	—	95	MN6110A1003	88 lb-in	On/Off, Floating	24 Vac/Vdc	—	—	90
NMX24-3-T	NSR	90 lb-in	On/Off, Floating	24 Vac/Vdc	—	—	95	MN6110A1003	88 lb-in	On/Off, Floating	24 Vac/Vdc	—	—	90
NMX120-3	NSR	90 lb-in	On/Off, Floating	100-240 Vac	—	—	150	MN6110A1003	88 lb-in	On/Off, Floating	24 Vac/Vdc	—	—	90
NMX120-SR	NSR	90 lb-in	2-10 Vdc (4-20 mA)	100-240 Vac	2-10 Vdc	—	150	MN7510A2001	88 lb-in	On/Off, Floating, (0) 2-10 Vdc	24 Vac/Vdc	(0) 2-10 Vdc	—	90
NMCX24-MFT	NSR	90 lb-in	MFT	24 Vac/Vdc	Variable (0-10 Vdc)	—	150	MN7510A2001	88 lb-in	On/Off, Floating, (0) 2-10 Vdc	24 Vac/Vdc	(0) 2-10 Vdc	—	90
NMQX24-MFT	NSR	70 lb-in	MFT	24 Vac/Vdc	Variable (0-10 Vdc)	—	150	ML7174A2001	70 lb-in	(0) 2-10 Vdc	24 Vac/Vdc	—	—	90
NMB24-SR	NSR	90 lb-in	2-10 Vdc (4-20 mA)	24 Vac/Vdc	—	—	95	MN7510A2001	88 lb-in	On/Off, Floating, (0) 2-10 Vdc	24 Vac/Vdc	(0) 2-10 Vdc	—	90
NMCB24-SR	NSR	90 lb-in	2-10 Vdc (4-20 mA)	24 Vac/Vdc	2-10 Vdc	—	45	MN7510A2001	88 lb-in	On/Off, Floating, (0) 2-10 Vdc	24 Vac/Vdc	(0) 2-10 Vdc	—	90
NMX24-SR	NSR	90 lb-in	2-10 Vdc (4-20 mA)	24 Vac/Vdc	2-10 Vdc	—	95	MN7510A2001	88 lb-in	On/Off, Floating, (0) 2-10 Vdc	24 Vac/Vdc	(0) 2-10 Vdc	—	90
NMX24-SR-T	NSR	90 lb-in	2-10 Vdc (4-20 mA)	24 Vac/Vdc	—	—	95	MN7510A2001	88 lb-in	On/Off, Floating, (0) 2-10 Vdc	24 Vac/Vdc	(0) 2-10 Vdc	—	90
NMB24-MFT	NSR	90 lb-in	MFT	24 Vac/Vdc	Variable (0-10 Vdc)	—	150	MN7510A2001	88 lb-in	On/Off, Floating, (0) 2-10 Vdc	24 Vac/Vdc	(0) 2-10 Vdc	—	90
NMX24-MFT	NSR	90 lb-in	MFT	24 Vac/Vdc	Variable (0-10 Vdc)	—	150	MN7510A2001	88 lb-in	On/Off, Floating, (0) 2-10 Vdc	24 Vac/Vdc	(0) 2-10 Vdc	—	90
AMB24-3	NSR	180 lb-in	On/Off, Floating	24 Vac/Vdc	—	—	95	MN6120A1002	175 lb-in	On/Off, Floating	24 Vac/Vdc	—	—	90
AMX24-3	NSR	180 lb-in	On/Off, Floating	24 Vac/Vdc	—	—	95	MN6120A1002	175 lb-in	On/Off, Floating	24 Vac/Vdc	—	—	90
AMX24-3-T	NSR	180 lb-in	On/Off, Floating	24 Vac/Vdc	—	—	95	MN6120A1002	175 lb-in	On/Off, Floating	24 Vac/Vdc	—	—	90
AMB24-3-S	NSR	180 lb-in	On/Off, Floating	24 Vac/Vdc	—	1	95	MN6120A1200	175 lb-in	On/Off, Floating	24 Vac/Vdc	—	2	90
AMB24-SR	NSR	180 lb-in	2-10 Vdc (4-20 mA)	24 Vac/Vdc	2-10 Vdc	—	95	MN7220A2007	175 lb-in	On/Off, Floating, (0) 2-10 Vdc	24 Vac/Vdc	(0) 2-10 Vdc	—	90
AMX24-SR	NSR	180 lb-in	2-10 Vdc (4-20 mA)	24 Vac/Vdc	2-10 Vdc	—	95	MN7220A2007	175 lb-in	On/Off, Floating, (0) 2-10 Vdc	24 Vac/Vdc	(0) 2-10 Vdc	—	90
AMX24-SR-T	NSR	180 lb-in	2-10 Vdc (4-20 mA)	24 Vac/Vdc	—	—	95	MN7220A2007	175 lb-in	On/Off, Floating, (0) 2-10 Vdc	24 Vac/Vdc	(0) 2-10 Vdc	—	90
AMB24-MFT	NSR	180 lb-in	MFT	24 Vac/Vdc	Variable (0-10 Vdc)	—	150	MN7220A2007	175 lb-in	On/Off, Floating, (0) 2-10 Vdc	24 Vac/Vdc	(0) 2-10 Vdc	—	90
AMX24-MFT	NSR	180 lb-in	MFT	24 Vac/Vdc	Variable (0-10 Vdc)	—	150	MN7220A2007	175 lb-in	On/Off, Floating, (0) 2-10 Vdc	24 Vac/Vdc	(0) 2-10 Vdc	—	90
AMX120-3	NSR	180 lb-in	On/Off, Floating	100-240 Vac	—	—	95	MN6120A1002	175 lb-in	On/Off, Floating	24 Vac/Vdc	—	—	90
AMX120-SR	NSR	180 lb-in	2-10 Vdc (4-20 mA)	100-240 Vac	2-10 Vdc	—	95	MN6120A1002	175 lb-in	On/Off, Floating	24 Vac/Vdc	(0) 2-10 Vdc	—	90
AMQX24-MFT	NSR	140 lb-in	MFT	24 Vac/Vdc	Variable (0-10 Vdc)	—	150	MN7220A2007	175 lb-in	On/Off, Floating, (0) 2-10 Vdc	24 Vac/Vdc	(0) 2-10 Vdc	—	90
GMB24-3	NSR	360 lb-in	On/Off, Floating	24 Vac/Vdc	—	—	150	MN6134A1003	300 lb-in	On/Off, Floating	24 Vac/Vdc	—	—	90
GMX24-3	NSR	360 lb-in	On/Off, Floating	24 Vac/Vdc	—	—	150	MN6134A1003	300 lb-in	On/Off, Floating	24 Vac/Vdc	—	—	90

Cross Reference - Actuators

Direct Coupled Actuators

Belimo Model	Fail Safe	Torque (lb-in)	Control Signal	Power	Feedback	Switches	Timing (sec)	Honeywell Model	Torque (lb-in)	Control Signal	Power	Feedback	Switches	Timing (sec)
GMB24-SR	NSR	360 lb-in	2-10 Vdc (4-20 mA)	24 Vac/Vdc	2-10 Vdc	—	150	MN7234A2008	300 lb-in	(0) 2-10 Vdc, (0) 4-20 mA	24 Vac/Vdc	(0) 2-10 Vdc	—	90
GMX24-SR	NSR	360 lb-in	2-10 Vdc (4-20 mA)	24 Vac/Vdc	2-10 Vdc	—	150	MN7234A2008	300 lb-in	(0) 2-10 Vdc, (0) 4-20 mA	24 Vac/Vdc	(0) 2-10 Vdc	—	90
GMB24-MFT	NSR	360 lb-in	On/Off, Floating	24 Vac/Vdc	—	—	150	MN6134A2008	300 lb-in	On/Off, Floating	24 Vac/Vdc	—	—	90
GMX24-MFT	NSR	360 lb-in	MFT	24 Vac/Vdc	Variable (0-10 Vdc)	—	150	MN7234A2008	300 lb-in	(0) 2-10 Vdc, (0) 4-20 mA	24 Vac/Vdc	(0) 2-10 Vdc	—	90
GMX120-3	NSR	360 lb-in	On/Off, Floating	100-240 Vac	—	—	150	MN6134A2008	300 lb-in	On/Off, Floating	24 Vac/Vdc	—	—	90
TFB24	SR	22 lb-in	On/Off	24 Vac/Vdc	—	—	75	MS8103A1030	27 lb-in	Two-Position (SPST)	24 Vac/Vdc	—	—	45
TFB24-S	SR	22 lb-in	On/Off	24 Vac/Vdc	—	1	75	MS8103A1130	27 lb-in	Two-Position (SPST)	24 Vac/Vdc	—	1	45
TFLB24	SR	22 lb-in	On/Off	24 Vac/Vdc	—	—	75	MS8103A1030	27 lb-in	Two-Position (SPST)	24 Vac/Vdc	—	—	45
TFB120	SR	22 lb-in	On/Off	100-240 Vac	—	—	75	MS4103A1030	27 lb-in	Two-Position (SPST)	100-250 Vac	—	—	45
TFB120-S	SR	22 lb-in	On/Off	100-240 Vac	—	1	75	MS4103A1130	27 lb-in	Two-Position (SPST)	100-250 Vac	—	1	45
TFLB120	SR	22 lb-in	On/Off	100-240 Vac	—	—	75	MS4103A1030	27 lb-in	Two-Position (SPST)	100-250 Vac	—	—	45
TFCB120-S	SR	22 lb-in	On/Off	100-240 Vac	—	1	30	MS4103A1130	27 lb-in	Two-Position (SPST)	100-250 Vac	—	1	45
TFB24-SR	SR	22 lb-in	2-10 Vdc (4-20 mA)	24 Vac/Vdc	2-10 Vdc	—	95	MS7103A2021	27 lb-in	(0) 2-10 Vdc	24 Vac/Vdc	(0) 2-10 Vdc	—	90
TFB24-SR-S	SR	22 lb-in	2-10 Vdc (4-20 mA)	24 Vac/Vdc	2-10 Vdc	1	95	MS7103A2221	27 lb-in	(0) 2-10 Vdc	24 Vac/Vdc	(0) 2-10 Vdc	2	90
TFB120-SR	SR	22 lb-in	2-10 Vdc (4-20 mA)	100-240 Vac	—	—	95	MS4103A1030	27 lb-in	Two-Position (SPST)	100-250 Vac	—	—	45
TFB24-3	SR	22 lb-in	Floating	24 Vac/Vdc	—	—	95	MS7503A2021	27 lb-in	On/Off, Floating, (0) 2-10 Vdc	24 Vac/Vdc	(0) 2-10 Vdc	—	90
TFB24-3-S	SR	22 lb-in	Floating	24 Vac/Vdc	—	1	95	MS7503A2221	27 lb-in	On/Off, Floating, (0) 2-10 Vdc	24 Vac/Vdc	(0) 2-10 Vdc	2	90
TFB24-MFT	SR	22 lb-in	MFT	24 Vac/Vdc	Variable (0-10 Vdc)	—	95	MS7503A2021	27 lb-in	On/Off, Floating, (0) 2-10 Vdc	24 Vac/Vdc	(0) 2-10 Vdc	—	90
TFB24-MFT-S	SR	22 lb-in	MFT	24 Vac/Vdc	Variable (0-10 Vdc)	1	95	MS7503A2221	27 lb-in	On/Off, Floating, (0) 2-10 Vdc	24 Vac/Vdc	(0) 2-10 Vdc	2	90
TFX24	SR	22 lb-in	On/Off	24 Vac/Vdc	—	—	<75	MS8105W1030	44 lb-in	Two-Position (SPST)	24 Vac/Vdc	—	—	45
TFX24-S	SR	22 lb-in	On/Off	24 Vac/Vdc	—	1	<75	MS8105W1130	44 lb-in	Two-Position (SPST)	24 Vac/Vdc	—	1	45
TFX24-SR	SR	22 lb-in	2-10 Vdc (4-20 mA)	24 Vac/Vdc	2-10 Vdc	—	95	MS7505W2030	44 lb-in	On/Off, Floating, (0) 2-10 Vdc	24 Vac/Vdc	(0) 2-10 Vdc	—	90
TFX24-SR-S	SR	22 lb-in	2-10 Vdc (4-20 mA)	24 Vac/Vdc	2-10 Vdc	1	95	MS7505W2130	44 lb-in	On/Off, Floating, (0) 2-10 Vdc	24 Vac/Vdc	(0) 2-10 Vdc	1	90
TFX24-3	SR	22 lb-in	Floating	24 Vac/Vdc	—	—	95	MS7505W2030	44 lb-in	On/Off, Floating, (0) 2-10 Vdc	24 Vac/Vdc	(0) 2-10 Vdc	—	90
TFX24-3-S	SR	22 lb-in	Floating	24 Vac/Vdc	—	1	95	MS7505W2130	44 lb-in	On/Off, Floating, (0) 2-10 Vdc	24 Vac/Vdc	(0) 2-10 Vdc	1	90
TFX24-MFT	SR	22 lb-in	MFT	24 Vac/Vdc	Variable (0-10 Vdc)	—	150	MS7505W2030	44 lb-in	On/Off, Floating, (0) 2-10 Vdc	24 Vac/Vdc	(0) 2-10 Vdc	—	90
TFX24-MFT-S	SR	22 lb-in	MFT	24 Vac/Vdc	Variable (0-10 Vdc)	1	150	MS7505W2130	44 lb-in	On/Off, Floating, (0) 2-10 Vdc	24 Vac/Vdc	(0) 2-10 Vdc	1	90
LF24-S US	SR	35 lb-in	On/Off	24 Vac/Vdc	—	1	40-75	MS8105A1130	44 lb-in	Two-Position (SPST)	24 Vac/Vdc	—	1	45
LF120 US	SR	35 lb-in	On/Off	120 Vac	—	—	40-75	MS4105A1030	44 lb-in	Two-Position (SPST)	100-250 Vac	—	—	45
LF120-S US	SR	35 lb-in	On/Off	120 Vac	—	1	40-75	MS4105A1130	44 lb-in	Two-Position (SPST)	100-250 Vac	—	1	45
LF230 US	SR	35 lb-in	On/Off	230 Vac	—	—	40-75	MS4105A1030	44 lb-in	Two-Position (SPST)	100-250 Vac	—	—	45
LF230-S US	SR	35 lb-in	On/Off	230 Vac	—	1	40-75	MS4105A1130	44 lb-in	Two-Position (SPST)	100-250 Vac	—	1	45
LF24-3 US	SR	35 lb-in	Modulating	24 Vac/Vdc	—	—	150	MS7505A2030	44 lb-in	On/Off, Floating, (0) 2-10 Vdc	24 Vac/Vdc	(0) 2-10 Vdc	—	90
LF24-3-S US	SR	35 lb-in	Modulating	24 Vac/Vdc	—	1	150	MS7505A2130	44 lb-in	On/Off, Floating, (0) 2-10 Vdc	24 Vac/Vdc	(0) 2-10 Vdc	1	90
LFC24-3-R US	SR	35 lb-in	Floating	24 Vac/Vdc	—	—	90	MS7505A2030	44 lb-in	On/Off, Floating, (0) 2-10 Vdc	24 Vac/Vdc	(0) 2-10 Vdc	—	90
LFC24-3-S US	SR	35 lb-in	Floating	24 Vac/Vdc	—	1	90	MS7505A2130	44 lb-in	On/Off, Floating, (0) 2-10 Vdc	24 Vac/Vdc	(0) 2-10 Vdc	1	90
LF24-SR US	SR	35 lb-in	2-10 Vdc (4-20 mA)	24 Vac/Vdc	2-10 Vdc	—	150	MS7505A2030	44 lb-in	On/Off, Floating, (0) 2-10 Vdc	24 Vac/Vdc	(0) 2-10 Vdc	—	90
LF24-SR-S US	SR	35 lb-in	2-10 Vdc (4-20 mA)	24 Vac/Vdc	2-10 Vdc	1	150	MS7505A2130	44 lb-in	On/Off, Floating, (0) 2-10 Vdc	24 Vac/Vdc	(0) 2-10 Vdc	1	90
LF24-SR-E US	SR	35 lb-in	2-10 Vdc, Built-in minimum position	24 Vac/Vdc	2-10 Vdc	—	150	MS7405A2030	44 lb-in	On/Off, Floating, (0) 2-10 Vdc, Economizer (3 kOhm, 3-Position)	24 Vac/Vdc	(0) 2-10 Vdc	—	90
LF24-MFT US	SR	35 lb-in	MFT	24 Vac/Vdc	2-10 Vdc	—	150	MS7505A2030	44 lb-in	On/Off, Floating, (0) 2-10 Vdc	24 Vac/Vdc	(0) 2-10 Vdc	—	90
LF24-MFT-S US	SR	35 lb-in	MFT	24 Vac/Vdc	2-10 Vdc	1	150	MS7505A2130	44 lb-in	On/Off, Floating, (0) 2-10 Vdc	24 Vac/Vdc	(0) 2-10 Vdc	1	90
LF24-MFT-20 US	SR	35 lb-in	MFT	24 Vac/Vdc	2-10 Vdc	—	150	MS7505A2030	44 lb-in	On/Off, Floating, (0) 2-10 Vdc	24 Vac/Vdc	(0) 2-10 Vdc	—	90
NFB24	SR	90 lb-in	On/Off	24 Vac/Vdc	—	—	<75	MS8110A1008	88 lb-in	Two-Position (SPST)	24 Vac/Vdc	—	—	45

Cross Reference - Actuators

Direct Coupled Actuators

Belimo Model	Fail Safe	Torque (lb-in)	Control Signal	Power	Feedback	Switches	Timing (sec)	Honeywell Model	Torque (lb-in)	Control Signal	Power	Feedback	Switches	Timing (sec)
NFB24-S	SR	90 lb-in	On/Off	24 Vac/Vdc	—	2	<75	MS8110A1206	88 lb-in	Two-Position (SPST)	24 Vac/Vdc	—	2	45
NFBUP	SR	90 lb-in	On/Off	24-240Vac	—	—	<75	MS41101002	88 lb-in	Two-Position (SPST)	100-250 Vac	—	—	45
NFBUP-S	SR	90 lb-in	On/Off	24-240Vac	—	2	<75	MS4110A1200	88 lb-in	Two-Position (SPST)	100-250 Vac	—	2	45
NFB24-SR	SR	90 lb-in	2-10 Vdc (4-20 mA)	24 Vac/Vdc	2-10 Vdc	—	95	MS7510A2008	88 lb-in	On/Off, Floating, (0) 2-10 Vdc	24 Vac/Vdc	(0) 2-10 Vdc	—	90
NFB24-SR-S	SR	90 lb-in	2-10 Vdc (4-20 mA)	24 Vac/Vdc	2-10 Vdc	2	95	MS7510A2206	88 lb-in	On/Off, Floating, (0) 2-10 Vdc	24 Vac/Vdc	(0) 2-10 Vdc	2	90
NFB24-MFT	SR	90 lb-in	MFT	24 Vac/Vdc	Variable (0-10 Vdc)	—	150	MS7510A2008	88 lb-in	On/Off, Floating, (0) 2-10 Vdc	24 Vac/Vdc	(0) 2-10 Vdc	—	90
NFB24-MFT-S	SR	90 lb-in	0-135 kOhm	24 Vac/Vdc	Variable (0-10 Vdc)	2	150	MS7510A2206	88 lb-in	On/Off, Floating, (0) 2-10 Vdc	24 Vac/Vdc	(0) 2-10 Vdc	2	90
NFX24	SR	90 lb-in	On/Off	24 Vac/Vdc	—	—	<75	MS8110W1008	88 lb-in	Two-Position (SPST)	24 Vac/Vdc	—	—	45
NFX24-S	SR	90 lb-in	On/Off	24 Vac/Vdc	—	2	<75	MS8110W1206	88 lb-in	Two-Position (SPST)	24 Vac/Vdc	—	2	45
NFX24-SR	SR	90 lb-in	2-10 Vdc (4-20 mA)	24 Vac/Vdc	2-10 Vdc	—	95	MS7510W2008	88 lb-in	On/Off, Floating, (0) 2-10 Vdc	24 Vac/Vdc	(0) 2-10 Vdc	—	90
NFX24-SR-S	SR	90 lb-in	2-10 Vdc (4-20 mA)	24 Vac/Vdc	2-10 Vdc	2	95	MS7510W2206	88 lb-in	On/Off, Floating, (0) 2-10 Vdc	24 Vac/Vdc	(0) 2-10 Vdc	2	90
NFX24-MFT	SR	90 lb-in	MFT	24 Vac/Vdc	Variable (0-10 Vdc)	—	150	MS7510W2008	88 lb-in	On/Off, Floating, (0) 2-10 Vdc	24 Vac/Vdc	(0) 2-10 Vdc	—	90
NFX24-MFT-S	SR	90 lb-in	MFT	24 Vac/Vdc	Variable (0-10 Vdc)	2	150	MS7510W2206	88 lb-in	On/Off, Floating, (0) 2-10 Vdc	24 Vac/Vdc	(0) 2-10 Vdc	2	90
AF24 US	SR	133 lb-in	On/Off	24 Vac/Vdc	—	—	150	MS8120A1007	175 lb-in	Two-Position (SPST)	24 Vac/Vdc	—	—	45
AF24-S US	SR	133 lb-in	On/Off	24 Vac/Vdc	—	2	150	MS8120A1205	175 lb-in	Two-Position (SPST)	24 Vac/Vdc	—	2	45
AF120 US	SR	133 lb-in	On/Off	120 Vac	—	—	150	MS4120A1001	175 lb-in	Two-Position (SPST)	100-250 Vac	—	—	45
AF120-S US	SR	133 lb-in	On/Off	120 Vac	—	2	150	MS4120A1209	175 lb-in	Two-Position (SPST)	100-250 Vac	—	2	45
AF230 US	SR	133 lb-in	On/Off	230 Vac	—	—	150	MS4120A1001	175 lb-in	Two-Position (SPST)	100-250 Vac	—	—	45
AF230-S US	SR	133 lb-in	On/Off	230 Vac	—	2	150	MS4120A1209	175 lb-in	Two-Position (SPST)	100-250 Vac	—	2	45
AF24-SR US	SR	133 lb-in	2-10 Vdc (4-20 mA)	24 Vac/Vdc	2-10 Vdc	—	150	MS7520A2007	175 lb-in	On/Off, Floating, (0) 2-10 Vdc	24 Vac/Vdc	(0) 2-10 Vdc	—	90
AF24-MFT US	SR	133 lb-in	MFT	24 Vac/Vdc	2-10 Vdc	—	150	MS7520A2007	175 lb-in	On/Off, Floating, (0) 2-10 Vdc	24 Vac/Vdc	(0) 2-10 Vdc	—	90
AF24-MFT-S US	SR	133 lb-in	MFT	24 Vac/Vdc	2-10 Vdc	2	150	MS7520A2205	175 lb-in	On/Off, Floating, (0) 2-10 Vdc	24 Vac/Vdc	(0) 2-10 Vdc	2	90
AF24-MFT-S US	SR	133 lb-in	MFT	24 Vac/Vdc	2-10 Vdc	2	150	MS7520H2208	175 lb-in	On/Off, Floating, (0) 2-10 Vdc	24 Vac/Vdc	(0) 2-10 Vdc	2	90
AF24-MFT95 US	SR	133 lb-in	0-135 kOhm	24 Vac/Vdc	—	—	150	MS7520A2007 + Q7002B1009	175 lb-in	0-135 kOhm	24 Vac/Vdc	(0) 2-10 Vdc	—	90
AFB24	SR	180 lb-in	On/Off	24 Vac/Vdc	—	—	<75	MS8120A1007	175 lb-in	Two-Position (SPST)	24 Vac/Vdc	—	—	45
AFB24-S	SR	180 lb-in	On/Off	24 Vac/Vdc	—	2	<75	MS8120A1205	175 lb-in	Two-Position (SPST)	24 Vac/Vdc	—	2	45
AFBUP	SR	180 lb-in	On/Off	24-240Vac	—	—	<75	MS4120A1001	175 lb-in	Two-Position (SPST)	100-250 Vac	—	—	45
AFBUP-S	SR	180 lb-in	On/Off	24-240Vac	—	2	<75	MS4120A1209	175 lb-in	Two-Position (SPST)	100-250 Vac	—	2	45
AFB24-SR	SR	180 lb-in	2-10 Vdc (4-20 mA)	24 Vac/Vdc	2-10 Vdc	—	95	MS7520A2007	175 lb-in	On/Off, Floating, (0) 2-10 Vdc	24 Vac/Vdc	(0) 2-10 Vdc	—	90
AFB24-SR-S	SR	180 lb-in	2-10 Vdc (4-20 mA)	24 Vac/Vdc	2-10 Vdc	2	95	MS7520A2205	175 lb-in	On/Off, Floating, (0) 2-10 Vdc	24 Vac/Vdc	(0) 2-10 Vdc	2	90
AFB24-MFT	SR	180 lb-in	MFT	24 Vac/Vdc	Variable (0-10 Vdc)	—	150	MS7520A2007	175 lb-in	On/Off, Floating, (0) 2-10 Vdc	24 Vac/Vdc	(0) 2-10 Vdc	—	90
AFB24-MFT-S	SR	180 lb-in	MFT	24 Vac/Vdc	Variable (0-10 Vdc)	2	150	MS7520A2205	175 lb-in	On/Off, Floating, (0) 2-10 Vdc	24 Vac/Vdc	(0) 2-10 Vdc	2	90
AFB24-MFT95	SR	180 lb-in	0-135 kOhm	24 Vac/Vdc	Variable (0-10 Vdc)	—	150	MS7520A2007 + Q7002B1009	175 lb-in	On/Off, Floating, (0) 2-10 Vdc	24 Vac/Vdc	(0) 2-10 Vdc	—	90
AFX24	SR	180 lb-in	On/Off	24 Vac/Vdc	—	—	<75	MS8120W1007	175 lb-in	Two-Position (SPST)	24 Vac/Vdc	—	—	45
AFX24-S	SR	180 lb-in	On/Off	24 Vac/Vdc	—	2	<75	MS8120W1205	175 lb-in	Two-Position (SPST)	24 Vac/Vdc	—	2	45
AFX24-SR	SR	180 lb-in	2-10 Vdc (4-20 mA)	24 Vac/Vdc	2-10 Vdc	—	95	MS7520W2007	175 lb-in	On/Off, Floating, (0) 2-10 Vdc	24 Vac/Vdc	(0) 2-10 Vdc	—	90
AFX24-SR-S	SR	180 lb-in	2-10 Vdc (4-20 mA)	24 Vac/Vdc	2-10 Vdc	2	95	MS7520W2205	175 lb-in	On/Off, Floating, (0) 2-10 Vdc	24 Vac/Vdc	(0) 2-10 Vdc	2	90
AFX24MFT	SR	180 lb-in	MFT	24 Vac/Vdc	Variable (0-10 Vdc)	—	150	MS7520W2007	175 lb-in	On/Off, Floating, (0) 2-10 Vdc	24 Vac/Vdc	(0) 2-10 Vdc	—	90
AFX24-MFT-S	SR	180 lb-in	MFT	24 Vac/Vdc	Variable (0-10 Vdc)	2	150	MS7520W2205	175 lb-in	On/Off, Floating, (0) 2-10 Vdc	24 Vac/Vdc	(0) 2-10 Vdc	2	90
AFX24-MFT95	SR	180 lb-in	0-135 kOhm	24 Vac/Vdc	Variable (0-10 Vdc)	—	150	MS7520W2007 + Q7002B1009	175 lb-in	On/Off, Floating, (0) 2-10 Vdc	24 Vac/Vdc	(0) 2-10 Vdc	—	90

Belimo Notes: All models described as (0) 2-10 Vdc can be used with a 4-20 mA control input. Shunt a 500 kOhm, 1/2 W resistor across the input at the actuator.

Cross Reference - Actuators

Direct Coupled Actuators

Johnson Model	Fail Safe	Torque (lb-in)	Control Signal	Power	Feedback	Switches	Timing (sec)	Honeywell Model	Torque (lb-in)	Control Signal	Power	Feedback	Switches	Timing (sec)
M9102-AGA-2S	NSR	18 lb-in	Floating	18 to 30 Vac at 50/60 Hz	—	—	30	ML6161A2009	35 lb-in	On/Off, Floating	24 Vac/Vdc	—	—	90
M9102-AGA-3S	NSR	18 lb-in	Floating	18 to 30 Vac at 50/60 Hz	—	—	30	ML6161A2009	35 lb-in	On/Off, Floating	24 Vac/Vdc	—	—	90
M9102-IGA-2S	NSR	18 lb-in	On/Off, Floating	18 to 30 Vac at 50/60 Hz	—	—	30	ML6161A2009	35 lb-in	On/Off, Floating	24 Vac/Vdc	—	—	90
M9102-IGA-3S	NSR	18 lb-in	On/Off, Floating	18 to 30 Vac at 50/60 Hz	—	—	30	ML6161A2009	35 lb-in	On/Off, Floating	24 Vac/Vdc	—	—	90
M9104-AGA-2S	NSR	35 lb-in	Floating	18 to 30 Vac at 50/60 Hz	—	—	60	ML6161A2009	35 lb-in	On/Off, Floating	24 Vac/Vdc	—	—	90
M9104-AGA-3S	NSR	35 lb-in	Floating	18 to 30 Vac at 50/60 Hz	—	—	60	ML6161A2009	35 lb-in	On/Off, Floating	24 Vac/Vdc	—	—	90
M9104-IGA-2S	NSR	35 lb-in	On/Off, Floating	18 to 30 Vac at 50/60 Hz	—	—	60	ML6161A2009	35 lb-in	On/Off, Floating	24 Vac/Vdc	—	—	90
M9104-IGA-3S	NSR	35 lb-in	On/Off, Floating	18 to 30 Vac at 50/60 Hz	—	—	60	ML6161A2009	35 lb-in	On/Off, Floating	24 Vac/Vdc	—	—	90
M9104-GGA-2S	NSR	35 lb-in	(0) 2-10 Vdc, (0) 4-20 mA, Reversible	18 to 30 Vac at 50/60 Hz	(0) 2-10 Vdc	—	60	ML7161A2008 + 200976C	35 lb-in	(0) 2-10 Vdc, (0) 4-20 mA	24 Vac/Vdc	0-2 kOhm	—	90
M9104-GGA-3S	NSR	35 lb-in	(0) 2-10 Vdc, (0) 4-20 mA, Reversible	18 to 30 Vac at 50/60 Hz	(0) 2-10 Vdc	—	60	ML7161A2008 + 200976C	35 lb-in	(0) 2-10 Vdc, (0) 4-20 mA	24 Vac/Vdc	0-2 kOhm	—	90
M9104-AGA-2N	NSR	35 lb-in	Floating	20 to 30 Vac at 50/60 Hz	—	—	90/108 (at 60/50 Hz)	MN6105A1011	44 lb-in	On/Off, Floating	24 Vac/Vdc	—	—	90
M9104-AGS-2N	NSR	35 lb-in	Floating	20 to 30 Vac at 50/60 Hz	—	—	90/108 (at 60/50 Hz)	MN6105A1011	44 lb-in	On/Off, Floating	24 Vac/Vdc	—	—	90
M9106-IGA-2	NSR	53 lb-in & 35 lb-in	On/Off, Floating	20 to 30 Vac at 50/60 Hz	—	—	Selectable: 60, 90, 120, 330, or 660 (at 60 Hz). 72, 108, 144, 396, or 792 (at 50 Hz).	MN6105A1011	44 lb-in	On/Off, Floating	24 Vac/Vdc	—	—	90
M9106-IGC-2	NSR	53 lb-in & 35 lb-in	On/Off, Floating	20 to 30 Vac at 50/60 Hz	—	2	Selectable: 60, 90, 120, 330, or 660 (at 60 Hz). 72, 108, 144, 396, or 792 (at 50 Hz).	MN6105A1201	44 lb-in	On/Off, Floating	24 Vac/Vdc	—	2	90
M9106-AGA-2	NSR	53 lb-in	Floating	20 to 30 Vac at 50/60 Hz	—	—	60/72 (at 60/50 Hz)	MN6110A1003	88 lb-in	On/Off, Floating	24 Vac/Vdc	—	—	90
M9106-AGA2N01	NSR	53 lb-in	Floating	20 to 30 Vac at 50/60 Hz	—	—	60/72 (at 60/50 Hz)	MN6110A1003	88 lb-in	On/Off, Floating	24 Vac/Vdc	—	—	90
M9106-AGA2N02	NSR	53 lb-in	Floating	20 to 30 Vac at 50/60 Hz	—	—	120/144 (at 60/50 Hz)	MN6110A1003	88 lb-in	On/Off, Floating	24 Vac/Vdc	—	—	90
M9106-AGC-2	NSR	53 lb-in	Floating	20 to 30 Vac at 50/60 Hz	—	2	60/72 (at 60/50 Hz)	MN6110A1201	88 lb-in	On/Off, Floating	24 Vac/Vdc	—	2	90
M9106-AGF-2	NSR	53 lb-in	Floating	20 to 30 Vac at 50/60 Hz	0-10 kOhm	—	60/72 (at 60/50 Hz)	ML6174B2019 + 200976C	70 lb-in	On/Off, Floating	24 Vac	0-2 kOhm	—	90
M9106-GGA-2	NSR	53 lb-in	(0) 2-10 Vdc, (0) 4 to 20 mA	20 to 30 Vac at 50/60 Hz	(0) 2-10 Vdc for 90 (1 mA at 10 Vdc). Corresponds to span selection.	—	60/72 (at 60/50 Hz)	MN7510A2001	88 lb-in	On/Off, Floating, (0) 2-10 Vdc	24 Vac/Vdc	(0) 2-10 Vdc	—	90
M9106-GGC-2	NSR	53 lb-in	(0) 2-10 Vdc, (0) 4 to 20 mA	20 to 30 Vac at 50/60 Hz	(0) 2-10 Vdc for 90 (1 mA at 10 Vdc). Corresponds to span selection.	2	60/72 (at 60/50 Hz)	MN7510A2209	88 lb-in	On/Off, Floating, (0) 2-10 Vdc	24 Vac/Vdc	(0) 2-10 Vdc	2	90
M9108-AGA-2	NSR	70 lb-in	On/Off, Floating	20 to 30 Vac at 50/60 Hz	—	—	25-50 for 0-70 lb-in, 30 at 50% load.	MN6110A1003	88 lb-in	On/Off, Floating	24 Vac/Vdc	—	—	90
M9108-AGC-2	NSR	70 lb-in	On/Off, Floating	20 to 30 Vac at 50/60 Hz	—	2	25-50 for 0-70 lb-in, 30 at 50% load.	MN6110A1201	88 lb-in	On/Off, Floating	24 Vac/Vdc	—	2	90

Cross Reference - Actuators

Direct Coupled Actuators

Johnson Model	Fail Safe	Torque (lb-in)	Control Signal	Power	Feedback	Switches	Timing (sec)	Honeywell Model	Torque (lb-in)	Control Signal	Power	Feedback	Switches	Timing (sec)
M9108-AGD-2	NSR	70 lb-in	On/Off, Floating	20 to 30 Vac at 50/60 Hz	0-135 kOhm	—	25-50 for 0-70 lb-in, 30 at 50% load.	ML6174B2019 + 200976A	70 lb-in	On/Off, Floating	24 Vac	0-500 kOhm	—	90
M9108-AGE-2	NSR	70 lb-in	On/Off, Floating	20 to 30 Vac at 50/60 Hz	0-1 kOhm	—	25-50 for 0-70 lb-in, 30 at 50% load.	ML6174B2019 + 200976C	70 lb-in	On/Off, Floating	24 Vac	0-2 kOhm	—	90
M9108-GGA-2	NSR	70 lb-in	0-20 Vdc (selectable zero and span), (0) 4 to 20 mA, Reversible.	20 to 30 Vac at 50/60 Hz	(0) 2-10 Vdc for 90 (1 mA at 10 Vdc). Corresponds to span selection.	—	25-50 for 0-70 lb-in, 30 at 50% load.	MN7510A2001	88 lb-in	On/Off, Floating, (0) 2-10 Vdc	24 Vac/Vdc	(0) 2-10 Vdc	—	90
M9108-GGC-2	NSR	70 lb-in	0-20 Vdc (selectable zero and span), (0) 4 to 20 mA, Reversible.	20 to 30 Vac at 50/60 Hz	(0) 2-10 Vdc for 90 (1 mA at 10 Vdc). Corresponds to span selection.	2	25-50 for 0-70 lb-in, 30 at 50% load.	MN7510A2209	88 lb-in	On/Off, Floating, (0) 2-10 Vdc	24 Vac/Vdc	(0) 2-10 Vdc	2	90
M9108-HGA-2	NSR	70 lb-in	0-20 Vdc (adjustable zero and span), (0) 4 to 20 mA, Reversible.	20 to 30 Vac at 50/60 Hz	(0) 2-10 Vdc for 90 (1 mA at 10 Vdc). Corresponds to span selection.	—	25-50 for 0-70 lb-in, 30 at 50% load.	MN7510A2001	88 lb-in	On/Off, Floating, (0) 2-10 Vdc	24 Vac/Vdc	(0) 2-10 Vdc	—	90
M9108-HGC-2	NSR	70 lb-in	0-20 Vdc (adjustable zero and span), (0) 4 to 20 mA, Reversible.	20 to 30 Vac at 50/60 Hz	(0) 2-10 Vdc for 90 (1 mA at 10 Vdc). Corresponds to span selection.	2	25-50 for 0-70 lb-in, 30 at 50% load.	MN7510A2209	88 lb-in	On/Off, Floating, (0) 2-10 Vdc	24 Vac/Vdc	(0) 2-10 Vdc	2	90
M9109-AGA-2	NSR	80 lb-in	Floating	20 to 30 Vac at 50/60 Hz	—	—	60/72 (at 60/50 Hz)	MN6110A1003	88 lb-in	On/Off, Floating	24 Vac/Vdc	—	—	90
M9109-AGC-2	NSR	80 lb-in	Floating	20 to 30 Vac at 50/60 Hz	—	2	60/72 (at 60/50 Hz)	MN6110A1201	88 lb-in	On/Off, Floating	24 Vac/Vdc	—	2	90
M9109-GGA-2	NSR	80 lb-in	(0) 2-10 Vdc, (0) 4-20 mA, Reversible	20 to 30 Vac at 50/60 Hz	(0) 2-10 Vdc for 90 (1 mA at 10 Vdc). Corresponds to span selection.	—	60/72 (at 60/50 Hz)	MN7510A2001	88 lb-in	On/Off, Floating, (0) 2-10 Vdc	24 Vac/Vdc	(0) 2-10 Vdc	—	90
M9109-GGC-2	NSR	80 lb-in	(0) 2-10 Vdc, (0) 4-20 mA, Reversible	20 to 30 Vac at 50/60 Hz	(0) 2-10 Vdc for 90 (1 mA at 10 Vdc). Corresponds to span selection.	2	60/72 (at 60/50 Hz)	MN7510A2209	88 lb-in	On/Off, Floating, (0) 2-10 Vdc	24 Vac/Vdc	(0) 2-10 Vdc	2	90
M9116-AGA-2	NSR	140 lb-in	On/Off, Floating	20 to 30 Vac at 50/60 Hz	—	—	70-115 for 0-140 lb-in, 80 at 50% load.	MN6120A1002	175 lb-in	On/Off, Floating	24 Vac/Vdc	—	—	90
M9116-AGC-2	NSR	140 lb-in	On/Off, Floating	20 to 30 Vac at 50/60 Hz	—	2	70-115 for 0-140 lb-in, 80 at 50% load.	MN6120A1200	175 lb-in	On/Off, Floating	24 Vac/Vdc	—	2	90
M9116-AGD-2	NSR	140 lb-in	On/Off, Floating	20 to 30 Vac at 50/60 Hz	0-135 kOhm	—	70-115 for 0-140 lb-in, 80 at 50% load.	MN6120A1002	175 lb-in	On/Off, Floating	24 Vac/Vdc	—	—	90
M9116-AGE-2	NSR	140 lb-in	On/Off, Floating	20 to 30 Vac at 50/60 Hz	0-1 kOhm	—	70-115 for 0-140 lb-in, 80 at 50% load.	MN6120A1002	175 lb-in	On/Off, Floating	24 Vac/Vdc	—	—	90
M9116-GGA-2	NSR	140 lb-in	(0) 2-10 Vdc, (0) 4-20 mA, Reversible	20 to 30 Vac at 50/60 Hz	(0) 2-10 Vdc for 90 (1 mA at 10 Vdc). Corresponds to span selection.	—	70-115 for 0-140 lb-in, 80 at 50% load.	MN7220A2007	175 lb-in	(0) 2-10 Vdc, (0) 4-20 mA	24 Vac/Vdc	(0) 2-10 Vdc	—	90
M9116-GGC-2	NSR	140 lb-in	(0) 2-10 Vdc, (0) 4-20 mA, Reversible	20 to 30 Vac at 50/60 Hz	(0) 2-10 Vdc for 90 (1 mA at 10 Vdc). Corresponds to span selection.	2	70-115 for 0-140 lb-in, 80 at 50% load.	MN7220A2205	175 lb-in	(0) 2-10 Vdc, (0) 4-20 mA	24 Vac/Vdc	(0) 2-10 Vdc	2	90
M9116-HGA-2	NSR	140 lb-in & 280 lb-in	(0) 2-10 Vdc, (0) 4-20 mA, Reversible	20 to 30 Vac at 50/60 Hz	(0) 2-10 Vdc for 90 (1 mA at 10 Vdc). Corresponds to span selection.	—	70-115 for 0-140 lb-in, 80 at 50% load.	MN7220A2007	175 lb-in	(0) 2-10 Vdc, (0) 4-20 mA	24 Vac/Vdc	(0) 2-10 Vdc	—	90

Cross Reference - Actuators

Direct Coupled Actuators

Johnson Model	Fail Safe	Torque (lb-in)	Control Signal	Power	Feedback	Switches	Timing (sec)	Honeywell Model	Torque (lb-in)	Control Signal	Power	Feedback	Switches	Timing (sec)
M9116-HGC-2	NSR	140 lb-in & 280 lb-in	(0) 2-10 Vdc, (0) 4-20 mA, Reversible	20 to 30 Vac at 50/60 Hz	(0) 2-10 Vdc for 90 (1 mA at 10 Vdc). Corresponds to span selection.	2	70-115 for 0-140 lb-in, 80 at 50% load.	MN7220A2205	175 lb-in	(0) 2-10 Vdc, (0) 4-20 mA	24 Vac/Vdc	(0) 2-10 Vdc	2	90
M9124-AGA-2	NSR	210 lb-in & 420 lb-in	On/Off, Floating	20 to 30 Vac at 50/60 Hz	—	—	115-175 for 0-210 lb-in, 130 at 50% load.	MN6134A1003	300 lb-in	On/Off, Floating	24 Vac/Vdc	—	—	90
M9124-AGC-2	NSR	210 lb-in	On/Off, Floating	20 to 30 Vac at 50/60 Hz	—	2	115-175 for 0-210 lb-in, 130 at 50% load.	MN6134A1003 + SW2-US	300 lb-in	On/Off, Floating	24 Vac/Vdc	—	2	90
M9124-AGD-2	NSR	210 lb-in	On/Off, Floating	20 to 30 Vac at 50/60 Hz	0-1 35 kOhm	—	115-175 for 0-210 lb-in, 130 at 50% load.	MN6134A1003	300 lb-in	On/Off, Floating	24 Vac/Vdc	—	—	90
M9124-AGE-2	NSR	210 lb-in	On/Off, Floating	20 to 30 Vac at 50/60 Hz	0-1 kOhm	—	115-175 for 0-210 lb-in, 130 at 50% load.	MN6134A1003	300 lb-in	On/Off, Floating	24 Vac/Vdc	—	—	90
M9124-GGA-2	NSR	210 lb-in & 420 lb-in	(0) 2-10 Vdc, (0) 4-20 mA, Reversible	20 to 30 Vac at 50/60 Hz	(0) 2-10 Vdc for 90 (1 mA at 10 Vdc). Corresponds to span selection.	—	115-175 for 0-210 lb-in, 130 at 50% load.	MN7234A2008	300 lb-in	(0) 2-10 Vdc, (0) 4-20 mA	24 Vac/Vdc	(0) 2-10 Vdc	—	90
M9124-GGC-2	NSR	210 lb-in & 420 lb-in	(0) 2-10 Vdc, (0) 4-20 mA, Reversible	20 to 30 Vac at 50/60 Hz	(0) 2-10 Vdc for 90 (1 mA at 10 Vdc). Corresponds to span selection.	2	115-175 for 0-210 lb-in, 130 at 50% load.	MN7234A2008 + SW2-US	300 lb-in	(0) 2-10 Vdc, (0) 4-20 mA	24 Vac/Vdc	(0) 2-10 Vdc	2	90
M9124-HGA-2	NSR	210 lb-in & 420 lb-in	(0) 2-10 Vdc, (0) 4-20 mA, Reversible	20 to 30 Vac at 50/60 Hz	(0) 2-10 Vdc for 90 (1 mA at 10 Vdc). Corresponds to span selection.	—	115-175 for 0-210 lb-in, 130 at 50% load.	MN7234A2008	300 lb-in	(0) 2-10 Vdc, (0) 4-20 mA	24 Vac/Vdc	(0) 2-10 Vdc	—	90
M9124-HGC-2	NSR	210 lb-in & 420 lb-in	(0) 2-10 Vdc, (0) 4-20 mA, Reversible	20 to 30 Vac at 50/60 Hz	(0) 2-10 Vdc for 90 (1 mA at 10 Vdc). Corresponds to span selection.	2	115-175 for 0-210 lb-in, 130 at 50% load.	MN7234A2008 + SW2-US	300 lb-in	(0) 2-10 Vdc, (0) 4-20 mA	24 Vac/Vdc	(0) 2-10 Vdc	2	90
M9132-AGA-2	NSR	280 lb-in	On/Off, Floating	20 to 30 Vac at 50/60 Hz	—	—	115-205 for 0-280 lb-in, 140 at 50% load.	MN6134A1003	300 lb-in	On/Off, Floating	24 Vac/Vdc	—	—	90
M9132-AGC-2	NSR	280 lb-in	On/Off, Floating	20 to 30 Vac at 50/60 Hz	—	2	115-205 for 0-280 lb-in, 140 at 50% load.	MN6134A1003 + SW2-US	300 lb-in	On/Off, Floating	24 Vac/Vdc	—	2	90
M9132-AGE-2	NSR	280 lb-in	On/Off, Floating	20 to 30 Vac at 50/60 Hz	0-1 kOhm	—	115-205 for 0-280 lb-in, 140 at 50% load.	MN6134A1003	300 lb-in	On/Off, Floating	24 Vac/Vdc	—	—	90
M9132-GGA-2	NSR	280 lb-in & 560 lb-in	(0) 2-10 Vdc, (0) 4 to 20 mA, Reversible	20 to 30 Vac at 50/60 Hz	(0) 2-10 Vdc for 90 (1 mA at 10 Vdc). Corresponds to span and stroke limits	—	115-205 for 0-280 lb-in, 140 at 50% load.	MN7234A2008	300 lb-in	(0) 2-10 Vdc, (0) 4-20 mA	24 Vac/Vdc	(0) 2-10 Vdc	—	90
M9132-GGC-2	NSR	280 lb-in & 560 lb-in	(0) 2-10 Vdc, (0) 4 to 20 mA, Reversible	20 to 30 Vac at 50/60 Hz	(0) 2-10 Vdc for 90 (1 mA at 10 Vdc). Corresponds to span and stroke limits	2	115-205 for 0-280 lb-in, 140 at 50% load.	MN7234A2008 + SW2-US	300 lb-in	(0) 2-10 Vdc, (0) 4-20 mA	24 Vac/Vdc	(0) 2-10 Vdc	2	90
M9203-AGA-2	SR	27 lb-in	On/Off, Floating	20 to 30 Vac at 50/60 Hz	—	—	150	MS7503A2021	27 lb-in	On/Off, Floating, (0) 2-10 Vdc	24 Vac/Vdc	(0) 2-10 Vdc	—	90
M9203-AGB-2	SR	27 lb-in	On/Off, Floating	20 to 30 Vac at 50/60 Hz	—	1	150	MS7503A2221	27 lb-in	On/Off, Floating, (0) 2-10 Vdc	24 Vac/Vdc	(0) 2-10 Vdc	2	90
M9203-AGA-2Z	SR	27 lb-in	On/Off, Floating	20 to 30 Vac at 50/60 Hz	—	—	90	MS7503A2021	27 lb-in	On/Off, Floating, (0) 2-10 Vdc	24 Vac/Vdc	(0) 2-10 Vdc	—	90
M9203-AGB-2Z	SR	27 lb-in	On/Off, Floating	20 to 30 Vac at 50/60 Hz	—	1	90	MS7503A2221	27 lb-in	On/Off, Floating, (0) 2-10 Vdc	24 Vac/Vdc	(0) 2-10 Vdc	2	90
M9203-BGA-2	SR	27 lb-in	On/Off	20 to 30 Vac at 50/60 Hz	—	—	< 75	MS8103A1030	27 lb-in	Two-Position (SPST)	24 Vac/Vdc	—	—	45

Cross Reference - Actuators

Direct Coupled Actuators

Johnson Model	Fail Safe	Torque (lb-in)	Control Signal	Power	Feedback	Switches	Timing (sec)	Honeywell Model	Torque (lb-in)	Control Signal	Power	Feedback	Switches	Timing (sec)
M9203-BGB-2	SR	27 lb-in	On/Off	20 to 30 Vac at 50/60 Hz	—	1	< 75	MS8103A1130	27 lb-in	Two-Position (SPST)	24 Vac/Vdc	—	1	45
M9203-BUA-2	SR	27 lb-in	On/Off	85 to 264 Vac at 50/60Hz	—	—	< 75	MS4103A1030	27 lb-in	Two-Position (SPST)	100-250 Vac	—	—	45
M9203-BUB-2	SR	27 lb-in	On/Off	85 to 264 Vac at 50/60Hz	—	1	< 75	MS4103A1130	27 lb-in	Two-Position (SPST)	100-250 Vac	—	1	45
M9203-GGA-2	SR	27 lb-in	(0) 2-10 Vdc, (0) 4-20 mA, Reversible	20 to 30 Vac at 50/60 Hz	(0) 2-10 Vdc	—	150	MS7503A2021	27 lb-in	On/Off, Floating, (0) 2-10 Vdc	24 Vac/Vdc	(0) 2-10 Vdc	—	90
M9203-GGB-2	SR	27 lb-in	(0) 2-10 Vdc, (0) 4-20 mA, Reversible	20 to 30 Vac at 50/60 Hz	(0) 2-10 Vdc	1	150	MS7503A2221	27 lb-in	On/Off, Floating, (0) 2-10 Vdc	24 Vac/Vdc	(0) 2-10 Vdc	2	90
M9203-GGA-2Z	SR	27 lb-in	(0) 2-10 Vdc, (0) 4-20 mA, Reversible	20 to 30 Vac at 50/60 Hz	(0) 2-10 Vdc	—	90	MS7503A2021	27 lb-in	On/Off, Floating, (0) 2-10 Vdc	24 Vac/Vdc	(0) 2-10 Vdc	—	90
M9203-GGB-2Z	SR	27 lb-in	(0) 2-10 Vdc, (0) 4-20 mA, Reversible	20 to 30 Vac at 50/60 Hz	(0) 2-10 Vdc	1	90	MS7503A2221	27 lb-in	On/Off, Floating, (0) 2-10 Vdc	24 Vac/Vdc	(0) 2-10 Vdc	2	90
M9208-AGA-2	SR	70 lb-in	On/Off, Floating	20 to 30 Vac at 50/60 Hz	—	—	150	MS7510A2008	88 lb-in	On/Off, Floating, (0) 2-10 Vdc	24 Vac/Vdc	(0) 2-10 Vdc	—	90
M9208-AGA-3	SR	70 lb-in	On/Off, Floating	20 to 30 Vac at 50/60 Hz	—	—	150	MS7510A2008	88 lb-in	On/Off, Floating, (0) 2-10 Vdc	24 Vac/Vdc	(0) 2-10 Vdc	—	90
M9208-AGC-3	SR	70 lb-in	On/Off, Floating	20 to 30 Vac at 50/60 Hz	—	2	150	MS7510A2206	88 lb-in	On/Off, Floating, (0) 2-10 Vdc	24 Vac/Vdc	(0) 2-10 Vdc	2	90
M9208-BGA-3	SR	70 lb-in	On/Off	18 to 30 Vac at 50/60 Hz	—	—	< 75	MS8110A1008	88 lb-in	Two-Position (SPST)	24 Vac/Vdc	—	—	45
M9208-BGC-3	SR	70 lb-in	On/Off	18 to 30 Vac at 50/60 Hz	—	2	< 75	MS8110A1206	88 lb-in	Two-Position (SPST)	24 Vac/Vdc	—	2	45
M9208-BAA-3	SR	70 lb-in	On/Off	102 to 132 Vac at 50/60 Hz	—	—	< 75	MS4110A1002	88 lb-in	Two-Position (SPST)	100-250 Vac	—	—	45
M9208-BAC-3	SR	70 lb-in	On/Off	102 to 132 Vac at 50/60 Hz	—	2	< 75	MS4110A1200	88 lb-in	Two-Position (SPST)	100-250 Vac	—	2	45
M9208-BDA-3	SR	70 lb-in	On/Off	198 to 264 Vac at 50/60 Hz	—	—	< 75	MS4110A1002	88 lb-in	Two-Position (SPST)	100-250 Vac	—	—	45
M9208-BDC-3	SR	70 lb-in	On/Off	198 to 264 Vac at 50/60 Hz	—	2	< 75	MS4110A1200	88 lb-in	Two-Position (SPST)	100-250 Vac	—	2	45
M9208-GGA-2	SR	70 lb-in	(0) 2-10 Vdc, (0) 4-20 mA, Reversible	20 to 30 Vac at 50/60 Hz	(0) 2-10 Vdc	—	150	MS7510A2008	88 lb-in	On/Off, Floating, (0) 2-10 Vdc	24 Vac/Vdc	(0) 2-10 Vdc	—	90
M9208-GGA-3	SR	70 lb-in	(0) 2-10 Vdc, (0) 4-20 mA, Reversible	20 to 30 Vac at 50/60 Hz	(0) 2-10 Vdc	—	150	MS7510A2008	88 lb-in	On/Off, Floating, (0) 2-10 Vdc	24 Vac/Vdc	(0) 2-10 Vdc	—	90
M9208-GGC-3	SR	70 lb-in	(0) 2-10 Vdc, (0) 4-20 mA, Reversible	20 to 30 Vac at 50/60 Hz	(0) 2-10 Vdc	2	150	MS7510A2206	88 lb-in	On/Off, Floating, (0) 2-10 Vdc	24 Vac/Vdc	(0) 2-10 Vdc	2	90
M9210-AGA-3	SR	89 lb-in	On/Off, Floating	20 to 30 Vac at 50/60 Hz	—	—	150	MS7510A2008	88 lb-in	On/Off, Floating, (0) 2-10 Vdc	24 Vac/Vdc	(0) 2-10 Vdc	—	90
M9210-AGC-3	SR	89 lb-in	On/Off, Floating	20 to 30 Vac at 50/60 Hz	—	2	150	MS7510A2206	88 lb-in	On/Off, Floating, (0) 2-10 Vdc	24 Vac/Vdc	(0) 2-10 Vdc	2	90
M9210-BGA-3	SR	89 lb-in	On/Off	20 to 30 Vac at 50/60 Hz	—	—	24 to 57	MS8110A1008	88 lb-in	Two-Position (SPST)	24 Vac/Vdc	—	—	45
M9210-BGC-3	SR	89 lb-in	On/Off	20 to 30 Vac at 50/60 Hz	—	2	24 to 57	MS8110A1206	88 lb-in	Two-Position (SPST)	24 Vac/Vdc	—	2	45
M9210-BAA-3	SR	89 lb-in	On/Off	102 to 132 Vac at 50/60 Hz	—	—	24 to 57	MS4110A1002	88 lb-in	Two-Position (SPST)	100-250 Vac	—	—	45
M9210-BAC-3	SR	89 lb-in	On/Off	102 to 132 Vac at 50/60 Hz	—	2	24 to 57	MS4110A1200	88 lb-in	Two-Position (SPST)	100-250 Vac	—	2	45
M9210-BDA-3	SR	89 lb-in	On/Off	198 to 264 Vac at 50/60 Hz	—	—	24 to 57	MS4110A1002	88 lb-in	Two-Position (SPST)	100-250 Vac	—	—	45

Cross Reference - Actuators

Direct Coupled Actuators

Johnson Model	Fail Safe	Torque (lb-in)	Control Signal	Power	Feedback	Switches	Timing (sec)	Honeywell Model	Torque (lb-in)	Control Signal	Power	Feedback	Switches	Timing (sec)
M9210-BDC-3	SR	89 lb-in	On/Off	198 to 264 Vac at 50/60 Hz	—	2	24 to 57	MS4110A1200	88 lb-in	Two-Position (SPST)	100-250 Vac	—	2	45
M9210-GGA-3	SR	89 lb-in	(0) 2-10 Vdc, (0) 4-20 mA, Reversible	20 to 30 Vac at 50/60 Hz	(0) 2-10 Vdc	—	150	MS7510A2008	88 lb-in	On/Off, Floating, (0) 2-10 Vdc	24 Vac/Vdc	(0) 2-10 Vdc	—	90
M9210-GGC-3	SR	89 lb-in	(0) 2-10 Vdc, (0) 4-20 mA, Reversible	20 to 30 Vac at 50/60 Hz	(0) 2-10 Vdc	2	150	MS7510A2206	88 lb-in	On/Off, Floating, (0) 2-10 Vdc	24 Vac/Vdc	(0) 2-10 Vdc	2	90
M9210-HGA-3	SR	89 lb-in	(0) 2-10 Vdc, (0) 4-20 mA, Reversible	20 to 30 Vac at 50/60 Hz	(0) 2-10 Vdc	—	150	MS7510A2008	88 lb-in	On/Off, Floating, (0) 2-10 Vdc	24 Vac/Vdc	(0) 2-10 Vdc	—	90
M9210-HGC-3	SR	89 lb-in	(0) 2-10 Vdc, (0) 4-20 mA, Reversible	20 to 30 Vac at 50/60 Hz	(0) 2-10 Vdc	2	150	MS7510A2206	88 lb-in	On/Off, Floating, (0) 2-10 Vdc	24 Vac/Vdc	(0) 2-10 Vdc	2	90
M9220-AGA-3	SR	177 lb-in	On/Off, Floating	20 to 30 Vac at 50/60 Hz	—	—	150	MS7520A2007	175 lb-in	On/Off, Floating, (0) 2-10 Vdc	24 Vac/Vdc	(0) 2-10 Vdc	—	90
M9220-AGC-3	SR	177 lb-in	On/Off, Floating	20 to 30 Vac at 50/60 Hz	—	2	150	MS7520A2205	175 lb-in	On/Off, Floating, (0) 2-10 Vdc	24 Vac/Vdc	(0) 2-10 Vdc	2	90
M9220-BGA-3	SR	177 lb-in	On/Off	20 to 30 Vac at 50/60 Hz	—	—	24 to 57	MS8120A1007	175 lb-in	Two-Position (SPST)	24 Vac/Vdc	—	—	45
M9220-BGC-3	SR	177 lb-in	On/Off	20 to 30 Vac at 50/60 Hz	—	2	24 to 57	MS8120A1205	175 lb-in	Two-Position (SPST)	24 Vac/Vdc	—	2	45
M9220-BAA-3	SR	177 lb-in	On/Off	102 to 132 Vac at 50/60 Hz	—	—	24 to 57	MS4120A1001	175 lb-in	Two-Position (SPST)	100-250 Vac	—	—	45
M9220-BAC-3	SR	177 lb-in	On/Off	102 to 132 Vac at 50/60 Hz	—	2	24 to 57	MS4120A1209	175 lb-in	Two-Position (SPST)	100-250 Vac	—	2	45
M9220-BDA-3	SR	177 lb-in	On/Off	198 to 264 Vac at 50/60 Hz	—	—	24 to 57	MS4120A1001	175 lb-in	Two-Position (SPST)	100-250 Vac	—	—	45
M9220-BDC-3	SR	177 lb-in	On/Off	198 to 264 Vac at 50/60 Hz	—	2	24 to 57	MS4120A1209	175 lb-in	Two-Position (SPST)	100-250 Vac	—	2	45
M9220-GGA-3	SR	177 lb-in	(0) 2-10 Vdc, (0) 4-20 mA, Reversible	20 to 30 Vac at 50/60 Hz	(0) 2-10 Vdc	—	150	MS7520A2007	175 lb-in	On/Off, Floating, (0) 2-10 Vdc	24 Vac/Vdc	(0) 2-10 Vdc	—	90
M9220-GGC-3	SR	177 lb-in	(0) 2-10 Vdc, (0) 4-20 mA, Reversible	20 to 30 Vac at 50/60 Hz	(0) 2-10 Vdc	2	150	MS7520A2205	175 lb-in	On/Off, Floating, (0) 2-10 Vdc	24 Vac/Vdc	(0) 2-10 Vdc	2	90
M9220-HGA-3	SR	177 lb-in	(0) 2-10 Vdc, (0) 4-20 mA, Reversible	20 to 30 Vac at 50/60 Hz	(0) 2-10 Vdc	—	150	MS7520A2007	175 lb-in	On/Off, Floating, (0) 2-10 Vdc	24 Vac/Vdc	(0) 2-10 Vdc	—	90
M9220-HGC-3	SR	177 lb-in	(0) 2-10 Vdc, (0) 4-20 mA, Reversible	20 to 30 Vac at 50/60 Hz	(0) 2-10 Vdc	2	150	MS7520A2205	175 lb-in	On/Off, Floating, (0) 2-10 Vdc	24 Vac/Vdc	(0) 2-10 Vdc	2	90

Johnson Notes: All models described as (0) 2-10 Vdc can be used with a 4-20 mA control input. Shunt a 500 kOhm, 1/2 W resistor across the input at the actuator.

Cross Reference - Actuators

Direct Coupled Actuators

Invensys Model	Fail Safe	Torque (lb-in)	Control Signal	Power	Feedback	Switches	Timing (sec)	Honeywell Model	Torque (lb-in)	Control Signal	Power	Feedback	Switches	Timing (sec)
MF41-6043	NSR	35 lb-in	Floating	24 Vac	—	—	< 90	MN6105A1011	44 lb-in	On/Off, Floating	24 Vac/Vdc	—	—	90
MF41-6043-502	NSR	35 lb-in	Floating	24 Vac	—	2	< 90	MN6105A1201	44 lb-in	On/Off, Floating	24 Vac/Vdc	—	2	90
MF41-6043-510	NSR	35 lb-in	Floating	24 Vac	0-1 kOhm	—	< 90	MN7505A2001	44 lb-in	On/Off, Floating, (0) 2-10 Vdc	24 Vac/Vdc	(0) 2-10 Vdc	—	90
MF41-6083	NSR	70 lb-in	Floating	24 Vac	—	—	< 125	MN6110A1003	88 lb-in	On/Off, Floating	24 Vac/Vdc	—	—	90
MF41-6083-502	NSR	70 lb-in	Floating	24 Vac	—	2	< 125	MN6110A1201	88 lb-in	On/Off, Floating	24 Vac/Vdc	—	2	90
MF41-6083-510	NSR	70 lb-in	Floating	24 Vac	0-1 kOhm	—	< 125	MN7510A2001	88 lb-in	On/Off, Floating, (0) 2-10 Vdc	24 Vac/Vdc	(0) 2-10 Vdc	—	90
MF41-6153	NSR	133 lb-in	Floating	24 Vac	—	—	< 125	MN6120A1002	175 lb-in	On/Off, Floating	24 Vac/Vdc	—	—	90
MF41-6343	NSR	300 lb-in	Floating	24 Vac	—	—	< 145	MN6134A1003	300 lb-in	On/Off, Floating	24 Vac/Vdc	—	—	90
MF4D-6043-100	NSR	35 lb-in	Floating	24 Vac, 20-30 Vdc	—	—	< 85	MS7505A2030	44 lb-in	On/Off, Floating, (0) 2-10 Vdc	24 Vac/Vdc	(0) 2-10 Vdc	—	90
MF4D-6083-100	NSR	70 lb-in	Floating	24 Vac, 20-30 Vdc	—	—	< 85	MS7510A2008	88 lb-in	On/Off, Floating, (0) 2-10 Vdc	24 Vac/Vdc	(0) 2-10 Vdc	—	90
MF4E-60430-100	NSR	35 lb-in	Floating	24 Vac	—	—	90	MN6105A1011	44 lb-in	On/Off, Floating	24 Vac/Vdc	—	—	90
MF4E-60830-100	NSR	70 lb-in	Floating	24 Vac	—	—	90	MN6110A1003	88 lb-in	On/Off, Floating	24 Vac/Vdc	—	—	90
MS41-6043	NSR	35 lb-in	0-10 Vdc	24 Vac	0-10 Vdc	—	< 90	MN7505A2001	44 lb-in	On/Off, Floating, (0) 2-10 Vdc	24 Vac/Vdc	(0) 2-10 Vdc	—	90
MS41-6043-502	NSR	35 lb-in	0-10 Vdc	24 Vac	0-10 Vdc	2	< 90	MN7505A2209	44 lb-in	On/Off, Floating, (0) 2-10 Vdc	24 Vac/Vdc	(0) 2-10 Vdc	2	90
MS41-6043-520	NSR	35 lb-in	0-10 Vdc (adjustable)	24 Vac	0-10 Vdc	—	< 90	MN7505A2001	44 lb-in	On/Off, Floating, (0) 2-10 Vdc	24 Vac/Vdc	(0) 2-10 Vdc	—	90
MS41-6043-522	NSR	35 lb-in	0-10 Vdc (adjustable)	24 Vac	0-10 Vdc	2	< 90	MN7505A2209	44 lb-in	On/Off, Floating, (0) 2-10 Vdc	24 Vac/Vdc	(0) 2-10 Vdc	2	90
MS41-6083	NSR	70 lb-in	0-10 Vdc	24 Vac	0-10 Vdc	—	< 125	MN7510A2001	88 lb-in	On/Off, Floating, (0) 2-10 Vdc	24 Vac/Vdc	(0) 2-10 Vdc	—	90
MS41-6083-502	NSR	70 lb-in	0-10 Vdc	24 Vac	0-10 Vdc	2	< 125	MN7510A2209	88 lb-in	On/Off, Floating, (0) 2-10 Vdc	24 Vac/Vdc	(0) 2-10 Vdc	2	90
MS41-6083-520	NSR	70 lb-in	0-10 Vdc (adjustable)	24 Vac	0-10 Vdc	—	< 125	MN7510A2001	88 lb-in	On/Off, Floating, (0) 2-10 Vdc	24 Vac/Vdc	(0) 2-10 Vdc	—	90
MS41-6083-522	NSR	70 lb-in	0-10 Vdc (adjustable)	24 Vac	0-10 Vdc	2	< 125	MN7510A2209	88 lb-in	On/Off, Floating, (0) 2-10 Vdc	24 Vac/Vdc	(0) 2-10 Vdc	2	90
MS41-6153	NSR	133 lb-in	0-10 Vdc	24 Vac	0-10 Vdc	—	< 125	MN7220A2007	175 lb-in	(0) 2-10 Vdc, (0) 4-20 mA	24 Vac/Vdc	(0) 2-10 Vdc	—	90
MS41-6153-502	NSR	133 lb-in	0-10 Vdc	24 Vac	0-10 Vdc	2	< 125	MN7220A2205	175 lb-in	(0) 2-10 Vdc, (0) 4-20 mA	24 Vac/Vdc	(0) 2-10 Vdc	2	90
MS41-6340	NSR	300 lb-in	2-10 Vdc, 4-20 mA	120 Vac	—	—	< 145	MN7234A2008	300 lb-in	(0) 2-10 Vdc, (0) 4-20 mA	24 Vac/Vdc	(0) 2-10 Vdc	—	90
MS41-6341	NSR	300 lb-in	2-10 Vdc, 4-20 mA	240 Vac	—	—	< 145	MN7234A2008	300 lb-in	(0) 2-10 Vdc, (0) 4-20 mA	24 Vac/Vdc	(0) 2-10 Vdc	—	90
MS41-6343	NSR	300 lb-in	2-10 Vdc, 4-20 mA	24 Vac	—	—	< 145	MN7234A2008	300 lb-in	(0) 2-10 Vdc, (0) 4-20 mA	24 Vac/Vdc	(0) 2-10 Vdc	—	90
MS4D-6043-100	NSR	35 lb-in	2-10 Vdc	24 Vac, 20-30 Vdc	2-10 Vdc	—	< 85	MN7505A2001	44 lb-in	On/Off, Floating, (0) 2-10 Vdc	24 Vac/Vdc	(0) 2-10 Vdc	—	90
MS4D-6043-150	NSR	35 lb-in	0-10 Vdc	24 Vac, 20-30 Vdc	2-10 Vdc	—	< 85	MN7505A2001	44 lb-in	On/Off, Floating, (0) 2-10 Vdc	24 Vac/Vdc	(0) 2-10 Vdc	—	90
MS4D-6043-160	NSR	35 lb-in	4-20 mA	24 Vac, 20-30 Vdc	2-10 Vdc	—	< 85	MN7505A2001	44 lb-in	On/Off, Floating, (0) 2-10 Vdc	24 Vac/Vdc	(0) 2-10 Vdc	—	90
MS4D-6083-100	NSR	70 lb-in	2-10 Vdc	24 Vac, 20-30 Vdc	2-10 Vdc	—	< 85	MN7510A2001	88 lb-in	On/Off, Floating, (0) 2-10 Vdc	24 Vac/Vdc	(0) 2-10 Vdc	—	90
MS4D-6083-150	NSR	70 lb-in	0-10 Vdc	24 Vac, 20-30 Vdc	2-10 Vdc	—	< 85	MN7510A2001	88 lb-in	On/Off, Floating, (0) 2-10 Vdc	24 Vac/Vdc	(0) 2-10 Vdc	—	90
MS4D-6083-160	NSR	70 lb-in	4-20 mA	24 Vac, 20-30 Vdc	2-10 Vdc	—	< 85	MN7510A2001	88 lb-in	On/Off, Floating, (0) 2-10 Vdc	24 Vac/Vdc	(0) 2-10 Vdc	—	90
MS50-H2001	NSR	300 lb-in	1-5 Vdc, 4-20 mA	120 Vac	—	—	145	MN7234A2008	300 lb-in	(0) 2-10 Vdc, (0) 4-20 mA	24 Vac/Vdc	(0) 2-10 Vdc	—	90
MS50-H2101	NSR	300 lb-in	1-5 Vdc, 4-20 mA	240 Vac	—	—	145	MN7234A2008	300 lb-in	(0) 2-10 Vdc, (0) 4-20 mA	24 Vac/Vdc	(0) 2-10 Vdc	—	90
MS50-H2301	NSR	300 lb-in	1-5 Vdc, 4-20 mA	24 Vac	—	—	145	MN7234A2008	300 lb-in	(0) 2-10 Vdc, (0) 4-20 mA	24 Vac/Vdc	(0) 2-10 Vdc	—	90
MA40-7043	SR	35 lb-in	On/Off	24 Vac, 22-30 Vdc	—	—	< 50	MS8105A1030	44 lb-in	Two-Position (SPST)	24 Vac/Vdc	—	—	45
MA40-7043-501	SR	35 lb-in	On/Off	24 Vac, 22-30 Vdc	—	1	< 50	MS8105A1130	44 lb-in	Two-Position (SPST)	24 Vac/Vdc	—	1	45
MA40-7170	SR	150 lb-in	On/Off	120 Vac	—	—	< 145	MS4120A1001	175 lb-in	Two-Position (SPST)	100-250 Vac	—	—	45
MA40-7171	SR	150 lb-in	On/Off	240 Vac	—	—	< 145	MS4120A1001	175 lb-in	Two-Position (SPST)	100-250 Vac	—	—	45
MA40-7173	SR	150 lb-in	On/Off	24 Vac, ±20%	—	—	< 145	MS8120A1007	175 lb-in	Two-Position (SPST)	24 Vac/Vdc	—	—	45
MA41-7073	SR	60 lb-in	On/Off	24 Vac, 22-30 Vdc	—	—	< 80	MS8110A1008	88 lb-in	Two-Position (SPST)	24 Vac/Vdc	—	—	45

Cross Reference - Actuators

Direct Coupled Actuators

Invensys Model	Fail Safe	Torque (lb-in)	Control Signal	Power	Feedback	Switches	Timing (sec)	Honeywell Model	Torque (lb-in)	Control Signal	Power	Feedback	Switches	Timing (sec)
MA41-7073-502	SR	60 lb-in	On/Off	24 Vac, 22-30 Vdc	—	2	< 80	MS8110A1206	88 lb-in	Two-Position (SPST)	24 Vac/Vdc	—	2	45
MA41-7153	SR	133 lb-in	On/Off	24 Vac, 22-30 Vdc	—	—	< 190	MS8120A1007	175 lb-in	Two-Position (SPST)	24 Vac/Vdc	—	—	45
MA41-7153-502	SR	133 lb-in	On/Off	24 Vac, 22-30 Vdc	—	2	< 190	MS8120A1205	175 lb-in	Two-Position (SPST)	24 Vac/Vdc	—	2	45
MA4D-7030-000	SR	30 lb-in	On/Off	120 Vac	—	—	< 56	MS4105A1030	44 lb-in	Two-Position (SPST)	100-250 Vac	—	—	45
MA4D-7031-000	SR	30 lb-in	On/Off	230 Vac	—	—	< 56	MS4105A1030	44 lb-in	Two-Position (SPST)	100-250 Vac	—	—	45
MA4D-7033-100	SR	30 lb-in	On/Off	24 Vac, 20-30 Vdc	—	—	< 56	MS8105A1008	44 lb-in	Two-Position (SPST)	24 Vac/Vdc	—	—	45
MA4D-8030-000	SR	30 lb-in	On/Off	120 Vac	—	—	< 56	MS4105A1030	44 lb-in	Two-Position (SPST)	100-250 Vac	—	—	45
MA4D-8031-000	SR	30 lb-in	On/Off	230 Vac	—	—	< 56	MS4105A1030	44 lb-in	Two-Position (SPST)	100-250 Vac	—	—	45
MA4D-8033-100	SR	30 lb-in	On/Off	24 Vac, 20-30 Vdc	—	—	< 56	MS8105A1008	44 lb-in	Two-Position (SPST)	24 Vac/Vdc	—	—	45
MF40-7043	SR	35 lb-in	Floating	24 Vac, 22-30 Vdc	—	—	< 130	MS7505A2030	44 lb-in	On/Off, Floating, (0) 2-10 Vdc	24 Vac/Vdc	(0) 2-10 Vdc	—	90
MF40-7043-501	SR	35 lb-in	Floating	24 Vac, 22-30 Vdc	—	1	< 130	MS7505A2130	44 lb-in	On/Off, Floating, (0) 2-10 Vdc	24 Vac/Vdc	(0) 2-10 Vdc	1	90
MF40-7173	SR	150 lb-in	Floating	24 Vac, ±20%	—	—	< 145	MS7520A2007	175 lb-in	On/Off, Floating, (0) 2-10 Vdc	24 Vac/Vdc	(0) 2-10 Vdc	—	90
MF41-7073	SR	60 lb-in	Floating	24 Vac, 22-30 Vdc	—	—	< 195	MS7510A2008	88 lb-in	On/Off, Floating, (0) 2-10 Vdc	24 Vac/Vdc	(0) 2-10 Vdc	—	90
MF41-7073-502	SR	60 lb-in	Floating	24 Vac, 22-30 Vdc	—	2	< 195	MS7510A2206	88 lb-in	On/Off, Floating, (0) 2-10 Vdc	24 Vac/Vdc	(0) 2-10 Vdc	2	90
MF41-7153	SR	133 lb-in	Floating	24 Vac, 22-30 Vdc	—	—	< 190	MS7520A2007	175 lb-in	On/Off, Floating, (0) 2-10 Vdc	24 Vac/Vdc	(0) 2-10 Vdc	—	90
MF41-7153-502	SR	133 lb-in	Floating	24 Vac, 22-30 Vdc	—	2	< 190	MS7520A2205	175 lb-in	On/Off, Floating, (0) 2-10 Vdc	24 Vac/Vdc	(0) 2-10 Vdc	2	90
MF4D-7033-100	SR	30 lb-in	Floating	24 Vac, 20-30 Vdc	2-10 Vdc	—	< 85	MS7505A2008	44 lb-in	On/Off, Floating, (0) 2-10 Vdc	24 Vac/Vdc	(0) 2-10 Vdc	—	90
MF4D-8033-100	SR	30 lb-in	Floating	24 Vac, 20-30 Vdc	2-10 Vdc	—	< 85	MS7505A2008	44 lb-in	On/Off, Floating, (0) 2-10 Vdc	24 Vac/Vdc	(0) 2-10 Vdc	—	90
MS40-7043	SR	35 lb-in	2-10 Vdc, 4-20 mA	24 Vac, 22-30 Vdc	2-10 Vdc	—	< 130	MS7505A2030	44 lb-in	On/Off, Floating, (0) 2-10 Vdc	24 Vac/Vdc	(0) 2-10 Vdc	—	90
MS40-7043-501	SR	35 lb-in	2-10 Vdc, 4-20 mA	24 Vac, 22-30 Vdc	2-10 Vdc	1	< 130	MS7505A2130	44 lb-in	On/Off, Floating, (0) 2-10 Vdc	24 Vac/Vdc	(0) 2-10 Vdc	1	90
MS40-7170	SR	150 lb-in	2-10 Vdc, 4-20 mA	120 Vac	—	—	< 145	MS7520A2007	175 lb-in	On/Off, Floating, (0) 2-10 Vdc	24 Vac/Vdc	(0) 2-10 Vdc	—	90
MS40-7171	SR	150 lb-in	2-10 Vdc, 4-20 mA	240 Vac	—	—	< 145	MS7520A2007	175 lb-in	On/Off, Floating, (0) 2-10 Vdc	24 Vac/Vdc	(0) 2-10 Vdc	—	90
MS40-7173	SR	150 lb-in	2-10 Vdc, 4-20 mA	24 Vac, ±20%	—	—	< 145	MS7520A2007	175 lb-in	On/Off, Floating, (0) 2-10 Vdc	24 Vac/Vdc	(0) 2-10 Vdc	—	90
MS41-7073	SR	60 lb-in	2-10 Vdc, 4-20 mA	24 Vac, 22-30 Vdc	2-10 Vdc	—	< 195	MS7510A2008	88 lb-in	On/Off, Floating, (0) 2-10 Vdc	24 Vac/Vdc	(0) 2-10 Vdc	—	90
MS41-7073-502	SR	60 lb-in	2-10 Vdc, 4-20 mA	24 Vac, 22-30 Vdc	2-10 Vdc	2	< 195	MS7510A2206	88 lb-in	On/Off, Floating, (0) 2-10 Vdc	24 Vac/Vdc	(0) 2-10 Vdc	2	90
MS41-7153	SR	133 lb-in	2-10 Vdc, 4-20 mA	24 Vac, 22-30 Vdc	2-10 Vdc	—	< 190	MS7520A2007	175 lb-in	On/Off, Floating, (0) 2-10 Vdc	24 Vac/Vdc	(0) 2-10 Vdc	—	90
MS41-7153-502	SR	133 lb-in	2-10 Vdc, 4-20 mA	24 Vac, 22-30 Vdc	2-10 Vdc	2	< 190	MS7520A2205	175 lb-in	On/Off, Floating, (0) 2-10 Vdc	24 Vac/Vdc	(0) 2-10 Vdc	2	90
MS4D-7033-100	SR	30 lb-in	2-10 Vdc, 4-20 mA	24 Vac, 20-30 Vdc	2-10 Vdc	—	< 85	MS7505A2008	44 lb-in	On/Off, Floating, (0) 2-10 Vdc	24 Vac/Vdc	(0) 2-10 Vdc	—	90
MS4D-7033-150	SR	30 lb-in	0-10 Vdc, 4-20 mA	24 Vac, 20-30 Vdc	2-10 Vdc	—	< 85	MS7505A2008	44 lb-in	On/Off, Floating, (0) 2-10 Vdc	24 Vac/Vdc	(0) 2-10 Vdc	—	90
MS4D-7033-160	SR	30 lb-in	4-20 mA	24 Vac, 22-30 Vdc	2-10 Vdc	—	< 85	MS7505A2008	44 lb-in	On/Off, Floating, (0) 2-10 Vdc	24 Vac/Vdc	(0) 2-10 Vdc	—	90
MS4D-8033-100	SR	30 lb-in	2-10 Vdc, 4-20 mA	24 Vac, 22-30 Vdc	2-10 Vdc	—	< 85	MS7505A2008	44 lb-in	On/Off, Floating, (0) 2-10 Vdc	24 Vac/Vdc	(0) 2-10 Vdc	—	90
MS4D-8033-150	SR	30 lb-in	0-10 Vdc, 4-20 mA	24 Vac, 22-30 Vdc	2-10 Vdc	—	< 85	MS7505A2008	44 lb-in	On/Off, Floating, (0) 2-10 Vdc	24 Vac/Vdc	(0) 2-10 Vdc	—	90
MS4D-8033-160	SR	30 lb-in	4-20 mA	24 Vac, 22-30 Vdc	2-10 Vdc	—	< 85	MS7505A2008	44 lb-in	On/Off, Floating, (0) 2-10 Vdc	24 Vac/Vdc	(0) 2-10 Vdc	—	90
MS50-E2001	SR	150 lb-in	1-5 Vdc, 4-20 mA	120 Vac	—	—	145	MS7520A2007	175 lb-in	On/Off, Floating, (0) 2-10 Vdc	24 Vac/Vdc	(0) 2-10 Vdc	—	90
MS50-E2101	SR	150 lb-in	1-5 Vdc, 4-20 mA	240 Vac	—	—	145	MS7520A2007	175 lb-in	On/Off	24 Vac/Vdc	(0) 2-10 Vdc	—	90
MS50-E2301	SR	150 lb-in	1-5 Vdc, 4-20 mA	24 Vac	—	—	145	MS7520A2007	175 lb-in	On/Off, Floating, (0) 2-10 Vdc	24 Vac/Vdc	(0) 2-10 Vdc	—	90

Invensys Notes: All models described as (0)2-10 Vdc can be used with a 4-20 mA control input. Shunt a 500 kOhm, 1/2 W resistor across the input at the actuator.

Cross Reference - Actuators

Direct Coupled Actuators

Siemens Model	Fail Safe	Torque (lb-in)	Control Signal	Power	Feedback	Switches	Timing (sec)	Honeywell Model	Torque (lb-in)	Control Signal	Power	Feedback	Switches	Timing (sec)
GDE131.1U	NSR	44 lb-in	Floating	24 Vac	—	—	90	MN6105A1011	44 lb-in	On/Off, Floating	24 Vac/Vdc	—	—	90
GDE131.1P	NSR	44 lb-in	Floating	24 Vac	—	—	90	MN6105W1011	44 lb-in	On/Off, Floating	24 Vac/Vdc	—	—	90
GDE161.1P	NSR	44 lb-in	0-10 Vdc	24 Vac	0-1 kOhm	—	90	MN7505A2001	44 lb-in	On/Off, Floating, (0) 2-10 Vdc	24 Vac/Vdc	(0) 2-10 Vdc	—	90
GDE132.1P	NSR	44 lb-in	Floating	24 Vac	0-1 kOhm	—	90	MN7505A2001	44 lb-in	On/Off, Floating, (0) 2-10 Vdc	24 Vac/Vdc	(0) 2-10 Vdc	—	90
GDE136.1P	NSR	44 lb-in	Floating	24 Vac	—	2	90	MN6105A1201	44 lb-in	On/Off, Floating	24 Vac/Vdc	—	2	90
GLB131.1P	NSR	88 lb-in	Floating	24 Vac	—	—	125	MN6110A1003	88 lb-in	On/Off, Floating	24 Vac/Vdc	—	—	90
GLB161.1P	NSR	88 lb-in	0-10 Vdc	24 Vac	—	—	125	MN7510A2001	88 lb-in	On/Off, Floating, (0) 2-10 Vdc	24 Vac/Vdc	(0) 2-10 Vdc	—	90
GLB132.1P	NSR	88 lb-in	Floating	24 Vac	0-1 kOhm	—	125	ML6174A2002 + 200976C	70 lb-in	On/Off, Floating	24 Vac	0-2 kOhm	—	90
GLB136.1P	NSR	88 lb-in	Floating	24 Vac	—	2	125	MN6110A1201	88 lb-in	On/Off, Floating	24 Vac/Vdc	—	2	90
GLB163.1P	NSR	88 lb-in	0-10 Vdc	24 Vac	—	—	125	MN7510A2001	88 lb-in	On/Off, Floating, (0) 2-10 Vdc	24 Vac/Vdc	(0) 2-10 Vdc	—	90
GLB164.1P	NSR	88 lb-in	0-10 Vdc	24 Vac	—	2	125	MN7510A2209	88 lb-in	On/Off, Floating, (0) 2-10 Vdc	24 Vac/Vdc	(0) 2-10 Vdc	2	90
GLB166.1P	NSR	88 lb-in	0-10 Vdc	24 Vac	—	2	125	MN7510A2209	88 lb-in	On/Off, Floating, (0) 2-10 Vdc	24 Vac/Vdc	(0) 2-10 Vdc	2	90
GEB131.1U	NSR	132 lb-in	Floating	24 Vac	—	—	125	MN6120A1002	175 lb-in	On/Off, Floating	24 Vac/Vdc	—	—	90
GEB136.1U	NSR	132 lb-in	Floating	24 Vac	—	2	125	MN6120A1200	175 lb-in	On/Off, Floating	24 Vac/Vdc	—	2	90
GEB161.1U	NSR	132 lb-in	0-10 Vdc	24 Vac	—	—	125	MN7220A2007	175 lb-in	(0) 2-10 Vdc, (0) 4-20 mA	24 Vac/Vdc	—	—	90
GBB171.1P	NSR	221 lb-in	On/Off, Floating	24 Vac	—	—	150	MN6120A1002	175 lb-in	On/Off, Floating	24 Vac/Vdc	—	—	90
GBB131.1U	NSR	221 lb-in	Floating	24 Vac	—	—	150	MN6120A1002	175 lb-in	On/Off, Floating	24 Vac/Vdc	—	—	90
GBB136.1U	NSR	221 lb-in	Floating	24 Vac	—	—	150	MN6120A1200	175 lb-in	On/Off, Floating	24 Vac/Vdc	—	—	90
GBB161.1U	NSR	221 lb-in	0-10 Vdc	24 Vac	—	—	150	MN7220A2007	175 lb-in	(0) 2-10 Vdc, (0) 4-20 mA	24 Vac/Vdc	(0) 2-10 Vdc	—	90
GBB166.1U	NSR	221 lb-in	0-10 Vdc	24 Vac	—	2	150	MN7220A2205	175 lb-in	(0) 2-10 Vdc, (0) 4-20 mA	24 Vac/Vdc	(0) 2-10 Vdc	2	90
GBB151.1P	NSR	221 lb-in	4-20 mA	24 Vac	—	—	150	MN7220A2007	175 lb-in	(0) 2-10 Vdc, (0) 4-20 mA	24 Vac/Vdc	(0) 2-10 Vdc	—	90
GBB166.1P	NSR	221 lb-in	0-10 Vdc	24 Vac	—	2	150	MN7220A2205	175 lb-in	(0) 2-10 Vdc, (0) 4-20 mA	24 Vac/Vdc	(0) 2-10 Vdc	2	90
GBB156.1P	NSR	221 lb-in	4-20 mA	24 Vac	—	2	150	MN7220A2205	175 lb-in	(0) 2-10 Vdc, (0) 4-20 mA	24 Vac/Vdc	(0) 2-10 Vdc	2	90
GIB131.1U	NSR	310 lb-in	Floating	24 Vac	—	—	150	MN6134A1003	300 lb-in	On/Off, Floating	24 Vac/Vdc	—	—	90
GIB136.1U	NSR	310 lb-in	Floating	24 Vac	—	2	150	MN6134A1003 + SW2-US	300 lb-in	On/Off, Floating	24 Vac/Vdc	—	2	90
GIB171.1U	NSR	310 lb-in	On/Off, Floating	24 Vac	—	—	150	MN6134A1003	300 lb-in	On/Off, Floating	24 Vac/Vdc	—	—	90
GIB161.1U	NSR	310 lb-in	0-10 Vdc	24 Vac	—	—	150	MN7234A2008	300 lb-in	(0) 2-10 Vdc, (0) 4-20 mA	24 Vac/Vdc	(0) 2-10 Vdc	—	90
GIB151.1U	NSR	310 lb-in	4-20 mA	24 Vac	—	—	150	MN7234A2008	300 lb-in	(0) 2-10 Vdc, (0) 4-20 mA	24 Vac/Vdc	(0) 2-10 Vdc	—	90
GIB166.1U	NSR	310 lb-in	0-10 Vdc	24 Vac	—	2	150	MN7234A2008 + SW-US2	300 lb-in	(0) 2-10 Vdc, (0) 4-20 mA	24 Vac/Vdc	(0) 2-10 Vdc	2	90
GIB156.1U	NSR	310 lb-in	4-20 mA	24 Vac	—	2	150	MN7234A2008 + SW2-US	300 lb-in	(0) 2-10 Vdc, (0) 4-20 mA	24 Vac/Vdc	(0) 2-10 Vdc	2	90
GQD121.1P	SR	20 lb-in	On/Off	24 Vac/dc	—	—	30	MS8103A1030	27 lb-in	Two-Position (SPST)	24 Vac/Vdc	—	—	45
GQD126.1P	SR	20 lb-in	On/Off	24 Vac/dc	—	2	30	MS8103A1130	27 lb-in	Two-Position (SPST)	24 Vac/Vdc	—	1	45
GQD221.1U	SR	20 lb-in	On/Off	120 Vac	—	—	30	MS4103A1030	27 lb-in	Two-Position (SPST)	100-250 Vac	—	—	45
GQD226.1U	SR	20 lb-in	On/Off	120 Vac	—	2	30	MS4103A1130	27 lb-in	Two-Position (SPST)	100-250 Vac	—	—	45
GQD131.1P	SR	20 lb-in	Floating	24 Vac/dc	—	—	30	MS7503A2021	27 lb-in	Floating, (0) 2-10 Vdc	24 Vac/Vdc	(0) 2-10 Vdc	—	90
GQD136.1P	SR	20 lb-in	Floating	24 Vac/dc	—	2	30	MS7503A2221	27 lb-in	Floating, (0) 2-10 Vdc	24 Vac/Vdc	(0) 2-10 Vdc	2	90
GQD151.1P	SR	20 lb-in	2-10 Vdc	24 Vac/dc	2-10 Vdc	—	30	MS7503A2021	27 lb-in	Floating, (0) 2-10 Vdc	24 Vac/Vdc	(0) 2-10 Vdc	—	90
GQD156.1P	SR	20 lb-in	2-10 Vdc	24 Vac/dc	2-10 Vdc	2	30	MS7503A2221	27 lb-in	Floating, (0) 2-10 Vdc	24 Vac/Vdc	(0) 2-10 Vdc	2	90
GMA121.1U	SR	62 lb-in	On/Off	24 Vac/dc	—	—	90	MS8110A1008	88 lb-in	Two-Position (SPST)	24 Vac/Vdc	—	—	45
GMA121.1P	SR	62 lb-in	On/Off	24 Vac/dc	—	—	90	MS8110W1008	88 lb-in	Two-Position (SPST)	24 Vac/Vdc	—	—	45
GMA126.1U	SR	62 lb-in	On/Off	24 Vac/dc	—	2	90	MS8110A1206	88 lb-in	Two-Position (SPST)	24 Vac/Vdc	—	2	45
GMA126.1P	SR	62 lb-in	On/Off	24 Vac/dc	—	2	90	MS8110W1206	88 lb-in	Two-Position (SPST)	24 Vac/Vdc	—	2	45
GMA221.1U	SR	62 lb-in	On/Off	120 Vac	—	—	90	MS4110A1002	88 lb-in	Two-Position (SPST)	100-250 Vac	—	—	45
GMA226.1U	SR	62 lb-in	On/Off	120 Vac	—	2	90	MS4110A1200	88 lb-in	Two-Position (SPST)	100-250 Vac	—	2	45
GMA131.1U	SR	62 lb-in	Floating	24 Vac/Vdc	—	—	90	MS7510A2008	88 lb-in	On/Off, Floating, (0) 2-10 Vdc	24 Vac/Vdc	(0) 2-10 Vdc	—	90
GMA131.1P	SR	62 lb-in	Floating	24 Vac/Vdc	—	—	90	MS7510W2008	88 lb-in	On/Off, Floating, (0) 2-10 Vdc	24 Vac/Vdc	(0) 2-10 Vdc	—	90

Cross Reference - Actuators

Direct Coupled Actuators

Siemens Model	Fail Safe	Torque (lb-in)	Control Signal	Power	Feedback	Switches	Timing (sec)	Honeywell Model	Torque (lb-in)	Control Signal	Power	Feedback	Switches	Timing (sec)
GMA132.1U	SR	62 lb-in	Floating	24 Vac/Vdc	0-1 kOhm	—	90	MS7510A2008	88 lb-in	On/Off, Floating, (0) 2-10 Vdc	24 Vac/Vdc	(0) 2-10 Vdc	—	90
GMA136.1U	SR	62 lb-in	Floating	24 Vac/dc	—	2	90	MS7510A2206	88 lb-in	On/Off, Floating, (0) 2-10 Vdc	24 Vac/Vdc	(0) 2-10 Vdc	2	90
GMA151.1U	SR	62 lb-in	2-10 Vdc	24 Vac/Vdc	0-1 kOhm	—	90	MS7510A2008	88 lb-in	(0) 2-10 Vdc, (0) 4-20 mA	24 Vac/Vdc	(0) 2-10 Vdc	—	90
GMA151.1P	SR	62 lb-in	2-10 Vdc	24 Vac/Vdc	0-1 kOhm	—	90	MS7510W2008	88 lb-in	(0) 2-10 Vdc, (0) 4-20 mA	24 Vac/Vdc	(0) 2-10 Vdc	—	90
GMA156.1U	SR	62 lb-in	2-10 Vdc	24 Vac/Vdc	0-1 kOhm	2	90	MS7510A2206	88 lb-in	On/Off, Floating, (0) 2-10 Vdc	24 Vac/Vdc	(0) 2-10 Vdc	2	90
GMA156.1P	SR	62 lb-in	2-10 Vdc	24 Vac/Vdc	0-1 kOhm	2	90	MS7510W2206	88 lb-in	(0) 2-10 Vdc, (0) 4-20 mA	24 Vac/Vdc	(0) 2-10 Vdc	2	90
GCA121.1U	SR	160 lb-in	On/Off	24 Vac/dc	—	—	90	MS8120A1007	175 lb-in	Two-Position (SPST)	24 Vac/Vdc	—	—	45
GCA121.1P	SR	160 lb-in	On/Off	24 Vac/dc	—	—	90	MS8120W1007	175 lb-in	Two-Position (SPST)	24 Vac/Vdc	—	—	45
GCA126.1U	SR	160 lb-in	On/Off	24 Vac/dc	—	2	90	MS8120A1205	175 lb-in	Two-Position (SPST)	24 Vac/Vdc	—	2	45
GCA126.1P	SR	160 lb-in	On/Off	24 Vac/dc	—	2	90	MS8120W1205	175 lb-in	Two-Position (SPST)	24 Vac/Vdc	—	2	45
GCA221.1U	SR	160 lb-in	On/Off	120 Vac	—	—	90	MS4120A1001	175 lb-in	Two-Position (SPST)	100-250 Vac	—	—	45
GCA226.1U	SR	160 lb-in	On/Off	120 Vac	—	2	90	MS4120A1209	175 lb-in	Two-Position (SPST)	100-250 Vac	—	2	45
GCA131.1U	SR	160 lb-in	Floating	24 Vac/dc	—	—	90	MS7520A2007	175 lb-in	On/Off, Floating, (0) 2-10 Vdc	24 Vac/Vdc	(0) 2-10 Vdc	—	90
GCA131.1P	SR	160 lb-in	Floating	24 Vac/dc	—	—	90	MS7520W2007	175 lb-in	On/Off, Floating, (0) 2-10 Vdc	24 Vac/Vdc	(0) 2-10 Vdc	—	90
GCA136.1U	SR	160 lb-in	Floating	24 Vac/dc	—	2	90	MS7520A2205	175 lb-in	On/Off, Floating, (0) 2-10 Vdc	24 Vac/Vdc	(0) 2-10 Vdc	2	90
GCA136.1P	SR	160 lb-in	Floating	24 Vac/dc	—	2	90	MS7520W2205	175 lb-in	On/Off, Floating, (0) 2-10 Vdc	24 Vac/Vdc	(0) 2-10 Vdc	2	90
GCA132.1U	SR	160 lb-in	Floating	24 Vac/dc	0-1 kOhm	—	90	MS7520A2007	175 lb-in	On/Off, Floating, (0) 2-10 Vdc	24 Vac/Vdc	(0) 2-10 Vdc	—	90
GCA132.1P	SR	160 lb-in	Floating	24 Vac/dc	0-1 kOhm	—	90	MS7520W2007	175 lb-in	On/Off, Floating, (0) 2-10 Vdc	24 Vac/Vdc	(0) 2-10 Vdc	—	90
GCA151.1U	SR	160 lb-in	4-20 mA	24 Vac/dc	—	—	90	MS7520A2007	175 lb-in	On/Off, Floating, (0) 2-10 Vdc	24 Vac/Vdc	(0) 2-10 Vdc	—	90
GCA151.1P	SR	160 lb-in	4-20 mA	24 Vac/dc	—	—	90	MS7520W2007	175 lb-in	On/Off, Floating, (0) 2-10 Vdc	24 Vac/Vdc	(0) 2-10 Vdc	—	90
GCA156.1U	SR	160 lb-in	4-20 mA	24 Vac/dc	—	2	90	MS7520A2205	175 lb-in	On/Off, Floating, (0) 2-10 Vdc	24 Vac/Vdc	(0) 2-10 Vdc	2	90
GCA156.1P	SR	160 lb-in	4-20 mA	24 Vac/dc	—	2	90	MS7520W2205	175 lb-in	On/Off, Floating, (0) 2-10 Vdc	24 Vac/Vdc	(0) 2-10 Vdc	2	90
GCA161.1U	SR	160 lb-in	0-10 Vdc	24 Vac/dc	—	—	90	MS7520A2007	175 lb-in	On/Off, Floating, (0) 2-10 Vdc	24 Vac/Vdc	(0) 2-10 Vdc	—	90
GCA161.1P	SR	160 lb-in	0-10 Vdc	24 Vac/dc	—	—	90	MS7520W2007	175 lb-in	On/Off, Floating, (0) 2-10 Vdc	24 Vac/Vdc	(0) 2-10 Vdc	—	90
GCA166.1U	SR	160 lb-in	0-10 Vdc	24 Vac/dc	—	2	90	MS7520A2205	175 lb-in	On/Off, Floating, (0) 2-10 Vdc	24 Vac/Vdc	(0) 2-10 Vdc	2	90
GCA166.1P	SR	160 lb-in	0-10 Vdc	24 Vac/dc	—	2	90	MS7520W2205	175 lb-in	On/Off, Floating, (0) 2-10 Vdc	24 Vac/Vdc	(0) 2-10 Vdc	2	90
GCA163.1U	SR	160 lb-in	0-10 Vdc	24 Vac/dc	—	—	90	MS7520H2208	175 lb-in	On/Off, Floating, (0) 2-10 Vdc	24 Vac/Vdc	(0) 2-10 Vdc	2	90
GCA164.1U	SR	160 lb-in	0-10 Vdc	24 Vac/dc	—	2	90	MS7520H2208	175 lb-in	On/Off, Floating, (0) 2-10 Vdc	24 Vac/Vdc	(0) 2-10 Vdc	2	90
GCA166.1P	SR	160 lb-in	0-10 Vdc	24 Vac/dc	—	2	90	MS7520W2205	175 lb-in	On/Off, Floating, (0) 2-10 Vdc	24 Vac/Vdc	(0) 2-10 Vdc	2	90

Siemens Notes: All models described as (0) 2-10 Vdc can be used with a 4-20 mA control input. Shunt a 500 kOhm, 1/2 W resistor across the input at the actuator.

