

anaco®



Coupling Company

Catalog 2014

Version 1.01

1001 El Camino Ave. Corona, CA 92879 Phone: (951) 372-2732 Fax: (951) 738-1183
www.anaco-husky.com

Table of Contents

NO HUB

No-hub Couplings List Price _____	1
No-hub Couplings Submittal _____	2
No-hub Couplings Installation Instructions _____	3

HUSKY SD 4000

Husky SD 4000 List Price _____	4
Husky SD 4000 Couplings Submittal _____	5
Husky SD 4000 Couplings Submittal (12" & 15") _____	6
Husky SD 4000 Couplings Reducer Submittal _____	7
Husky SD 4000 Couplings Transition Submittal _____	8
Husky SD 4000 Couplings Installation Suggestions _____	9

HUSKY HD 2000

Husky HD 2000 List Prices _____	10
Husky HD 2000 Submittal _____	11
Husky HD 2000 Reducer _____	12
Husky HD 2000 Transition Submittal _____	13
Husky HD 2000 Installation Suggestions _____	14

SERVICE WEIGHT GASKET

Service Weight Gasket List Prices _____	15
EZ-Tight Compression Gasket Submittal _____	16
Ty-Seal Gasket Submittal _____	17

SPECIALTY COUPLINGS

Cremco Specialty Transition Couplings List Price _____	18
Cremco Transition Couplings Submittal _____	20
Anaco Cap List Prices _____	21

RIGID QUIK

Rigid Quik List Prices _____	22
Rigid Quik Submittal _____	23

anaco® NO HUB COUPLINGS

List Prices

NH-711NAT July 1, 2011

ANACO Part #	Size	List Price	Carton Quantity	Weight Per carton
0002	1 1/2"	\$ 15.90	100	24 lbs.
0006	2"	\$ 15.90	100	27 lbs.
0008	3"	\$ 19.00	100	35 lbs.
0010	4"	\$ 22.45	100	42 lbs.
0012	5"	\$ 54.60	20	18 lbs.
0014	6"	\$ 56.90	25	25 lbs.
0016	8"	\$ 107.40	10	16 lbs.
0017	10"	\$141.80	10	20 lbs.

HEAVY DUTY NO-HUB COUPLINGS (Special Multiplier)

0018	12"	\$154.50	2	6.6
0020	15"	\$216.15	2	8.4

REDUCING COUPLINGS

0004	2x1-1/2 reducing	\$18.55	100	35
0005	3x2 reducing	\$28.85	60	42
0009	4x3 reducing	\$34.25	60	53
0013	4x2 reducing	\$40.90	60	69

We reserve the right to withdraw this sheet without notice and price in effect at time of shipment will apply.

Possession of this list price sheet shall not be construed as an offer to sell.

Freight: Prepaid on all orders of 750 or more



1001 El Camino Ave. Corona, CA 92879 Phone: (951) 372-2732 Fax: (951) 738-1183

www.anaco-husky.com

Submittal



CISPI 310

anaco No-Hub Couplings meet CISPI 310 and ASTM C 1277. Couplings consist of a stainless steel shield, clamp assembly and a gasket manufactured from a properly vulcanized virgin compound in which the primary elastomer is polychloroprene (neoprene) conforming to ASTM C 564.

Compliant to BAA, TAA, ARRA, NAFTA & NSF.

The couplings is used to join hubless cast iron pipe and fittings made to CISPI 301 and/ or ASTM A 888. Coupling size range from 1 ½” through 15” diameters. The stainless steel shield and clamp assemblies are corrosion resistant.

Material Specification

- Clamp:** Type 301 AISI stainless steel
- Screw:** Type 305 AISI stainless steel 5/16 hex head for 1 ½” - 10”, 3/8 for 12” & 15”
- Shield:** Type 301 AISI Stainless steel corrugated. Shield thickness 0.0075
- Housing:** Type 301 AISI stainless steel

Gasket Test

Test	Physical Tests Min. Or Max Requirements	ASTM Method
Tensile strength	1500 psi min.	D412
Elongation	250 min.	D412
Durometer [Shore A]	70 ± 5 @ 76° F ± 5° F	D2240
Accelerated Aging	15% maximum tensile and 20% maximum elongation deterioration, 10 points maximum increase in hardness, all determinations after oven aging for 96 hours at 158° F	D573
Compression Set	25% maximum after 22 hours at 158°F	D395 Method B
Oil Immersion	80% maximum volume change after immersion in IRM 903 for 70 hours at 212°F	D471
Ozone Cracking	No visible cracking at 2 times magnification of the gasket after 100 hours exposure in 1.5ppm ozone concentration at 100°F. Testing and inspection to be on gasket which is loop mounted to give approximately 20% elongation of outer surface.	D1149
Water Resistance	150 lbs. minimum per inch of thickness	D624
Water Absorption	20% maximum by weight after 7 days at 158°F	D471

NO HUB COUPLINGS

Installation Suggestions

Size	Width	No. of Straps	Torque
1 ½" - 4"	2.125	2	60
5 & 6	3.0	4	60
8 & 10	4.0	4	60
12 & 15	5.50	6	80

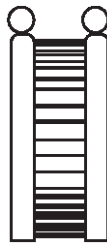

Size 1-1/2"
thru 4"
TWO BANDS
Figure 1

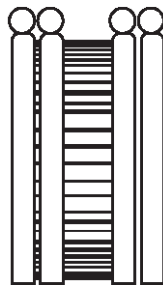

Size 5", 6"
8" thru 10"
FOUR BANDS
Figure 2

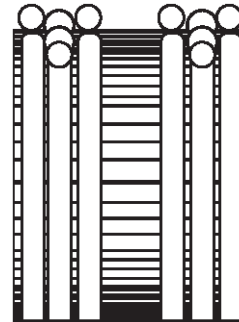

Size 12"
And 15"
SIX BANDS
Figure 3

Installation Instructions

- 1) After making the field cuts square and placing the ends of the pipes against the center-stop of the gasket, slide the clamp assembly into position centered over the gasket.
- 2) Using a torque wrench, tighten stainless steel screws alternately to 60-inch pounds torque for 1½ to 10" and 80-inch pounds torque for 12" & 15".
- 3) For 5" to 10" couplings, tighten inner bands first, then tighten outer bands.
- 4) For 12" & 15" couplings, tighten inner bands, center bands and outer bands. When min-max conditions exist, tighten each band starting on the smaller side: 3,2,1 and 3,2,1 again. Then torque the maximum side: 4, 5, 6 and 4, 5, 6 again. Finally, torque 2,1 on the minimum side and 4, 5, 6 on the maximum side. (See Figure 3 above)

Bracing

Horizontal pipe and fittings five inches and larger must be suitably braced to prevent horizontal movement. This must be done at every branch opening or change of direction by the use of braces, blocks, rodding or other suitable method, to prevent movement or joint separation. (Chapter IV, Handbook Cast Iron Soil Pipe Institute)

1001 El Camino Ave. Corona, CA 92879 Phone: (951) 372-2732 Fax: (951) 738-1183

www.anaco-husky.com

HUSKY® SD 4000**List Prices**

SD 711NAT July 1, 2011

Part Number	Coupling Size	Carton Quantity	Carton Weight	List Price
4002	1½"	60	32	17.15
4006	2"	75	45	18.30
4008	3"	48	37	21.10
4010	4"	48	44	24.60
4012	5"	15	25	50.50
4014	6"	15	28	59.80
4016	8"	15	35	118.40
4017	10"	12	33	152.25
4018	12"	2	8	194.40
4020	15"	2	9	248.30
Reducing Couplings	Coupling Size	Carton Quantity	Carton Weight	List Price
4004	2 x 1½"	36	27	19.65
4005	3 x 2"	24	27	28.10
4009	4 x 3"	15	22	33.30
4013	4 x 2"	15	20	38.90
Transition Couplings	Coupling Size	Carton Quantity	Carton Weight	List Price
4101	2 x 1½"	24	19	22.80
4102	2 x 2"	24	16	21.75

Terms: 2% 10th prox., net thereafter.

Full freight is allowed on all orders of \$2500 or 600 or more pieces.

Prices subject to change without notice.

Return goods restocking charge of 25% subject to factory charge authorization.

Orders will be subject to a 10% premium on broken case quantities only.



1001 El Camino Ave. Corona, CA 92879 Phone: (951) 372-2732 Fax: (951) 738-1183

www.anaco-husky.com



HUSKY® SERIES 4000 COUPLING

Product Information Submittal



Certifications & Standards

- Meets ASTM C 1540
- Meets ASTM C 564
- Meets F 1680 Class 1
- Meets CSA B 602
- lapmo File 6726

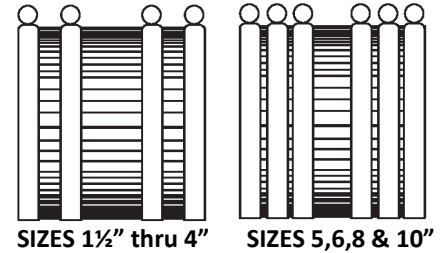

Size	Width	No. of Straps	Torque
1 ½" - 4"	3.0	4	80
5 & 6	4.0	6	80
8 & 10	4.0	6	80

Material Specifications

Clamp: Type 304 AISI Stainless steel

Screw: Type 305 AISI stainless steel 3/8

Shield: Type 304 AISI stainless steel, corrugated. Shield thickness 0.015

Gasket: The gasket shall be manufactured from a properly vulcanized virgin compound in which the primary elastomer is polychloroprene (neoprene) conforming to ASTM C 564. Oil Immersion test: 80% max. Volume Change after immersion in ASTM oil no. 3 for 70 hours at 212°F.

The **Husky SD 4000** Coupling has been engineered by **anaco** to provide a heavy duty, all stainless steel coupling, balancing the desire for a more rigid joint with the need to provide a superior positive seal, which can accommodate possible disparities in the mating of No-Hub pipe and fittings. This has been accomplished by manufacturing our coupling with a super-duty corrugated shield of sufficient width to accommodate additional surface-bearing sealing clamps.

The additional sealing clamps when torqued to 80 inch pounds, offer two salient performance related features. First, the overall dimensional thickness of the clamp and shield, in conjunction with the additional width of the coupling, result in a more uniformly rigid joint, with the load being supported at both the outer edge of the coupling and the centerline of the joint. Second, the additional sealing clamps yield increased surface-bearing contact between the coupling and the pipe or fittings, thereby inhibiting joint movement at higher internal pressures not commonly associated with a DWV system.

The 1½" through 4" diameter couplings consist of a 3" wide corrugated 304 stainless steel shield in conjunction with four (4) stainless steel clamps mounted in a series, secured in place by means of affixed and "floating" eyelet to allow the clamp "travel" during tightening.

The 5" through 10" diameter couplings consist of a 4" wide corrugated 304 stainless steel shield in conjunction with six (6) stainless steel clamps mounted in a series, secured in place by means of affixed and "floating" eyelet to allow the clamp "travel" during tightening.

All **SD 4000** Couplings are designed to be installed with a pre-set torque wrench calibrated at 80 inch pounds to accommodate the 305 stainless steel 3/8" Hex Head screw.

1001 El Camino Ave. Corona, CA 92879 Phone: (951) 372-2732 Fax: (951) 738-1183

www.anaco-husky.com



HUSKY® SERIES 4000 COUPLING

Product Information Submittal



Certifications & Standards

- Meets ASTM C 1540
- Meets ASTM C 564
- lapmo File 6726

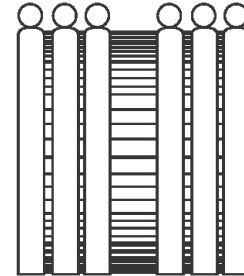

SIZES 12 & 15

Size	Width	No. of Straps	Torque
12 & 15"	5.5	6	80

Material Specifications

Clamp: Type 304 AISI Stainless steel

Screw: Type 305 AISI stainless steel 3/8

Shield: Type 304 AISI stainless steel, corrugated.

Gasket: The gasket shall be manufactured from a properly vulcanized virgin compound in which the primary elastomer is polychloroprene (neoprene) conforming to ASTM C 564. Oil Immersion test: 80% max. Volume Change after immersion in ASTM oil no. 3 for 70 hours at 212°F.

The **Husky SD 4000** Coupling has been engineered by **anaco** to provide a heavy duty, all stainless steel coupling, balancing the desire for a more rigid joint with the need to provide a superior positive seal, which can accommodate possible disparities in the mating of No-Hub pipe and fittings. This has been accomplished by manufacturing our coupling with a super-duty corrugated shield of sufficient width to accommodate additional surface-bearing sealing clamps.

The additional sealing clamps when torqued to 80 inch pounds, offer two salient performance related features. First, the overall dimensional thickness of the clamp and shield, in conjunction with the additional width of the coupling, result in a more uniformly rigid joint, with the load being supported at both the outer edge of the coupling and the centerline of the joint. Second, the additional sealing clamps yield increased surface-bearing contact between the coupling and the pipe or fittings, thereby inhibiting joint movement at higher internal pressures not commonly associated with a DWV system.

The 12 & 15" diameter couplings consist of a 5½" wide corrugated 304 stainless steel shield in conjunction with six (6) stainless steel clamps mounted in a series, secured in place by means of affixed and "floating" eyelet to allow the clamp "travel" during tightening.

All **SD 4000** Couplings are designed to be installed with a pre-set torque wrench calibrated at 80 inch pounds to accommodate the 305 stainless steel 3/8" Hex Head screw.

1001 El Camino Ave. Corona, CA 92879 Phone: (951) 372-2732 Fax: (951) 738-1183

www.anaco-husky.com



HUSKY® 4000 REDUCER COUPLING

Product Information Submittal

Test	Physical Tests Min. or Max Requirements	ASTM Method
Tensile Strength	1500 psi min.	D 412
Elongation	250 min.	D 412
Durometer [Shore A]	70 +/- 5 @ 76° F +/- 5°F.	D 2240
Accelerated Aging	15% maximum tensile and 20% maximum elongation deterioration, 10 points maximum increase in hardness, all determination after oven aging for 96 hours at 158°F	D 573
Compression Set	25% maximum after 22 hours at 158°F	D 395 method B
Oil Immersion	80% maximum volume change after immersion in IRM 903 for 70 hours at 212°F	D471
Ozone Cracking	No visible cracking at 2 times magnification of the gasket after 100 hours exposure in 1.5ppm ozone concentration at 100°F. Testing and inspection to be on gasket which is loop mounted to give approximately 20% elongation of outer surface.	D 1149
Tear Resistance	150Lbs. Minimum per inch of thickness	D 624
Water Absorption	20% maximum by weight after 7 days at 158°F	D 471

Materials

- Clamp: Type 304 AISI stainless steel.
- Screw: Type 305 AISI stainless steel 3/8"
- Shield: Type 304 AISI stainless steel, corrugated. Shield thickness .015
- Gasket: The gasket shall be manufactured from a properly vulcanized virgin compound in which the primary elastomer is polychloroprene (neoprene) conforming to ASTM C 564

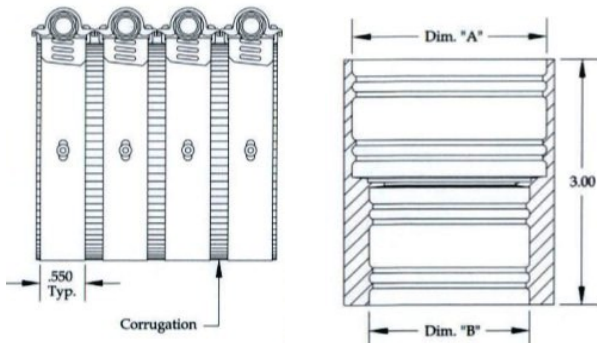

Application Data

Model	Size
4004	2"x1½"
4005	3"x2"
4009	4"x3"
4013	4"x2"

Certifications & Standards

- Meets **ASTM C 1540**
- Meets **ASTM C 564**
- **Iapmo File 6726**

The **HUSKY SD 4000** Coupling has been engineered by **anaco** to provide a heavy duty, all stainless steel coupling, balancing the desire for a more rigid joint with the need to provide a superior positive seal, which can accommodate possible disparities in mating of No-Hub pipe and fittings. This has been accomplished by manufacturing our coupling with a super-duty corrugated shield of sufficient width to accommodate additional surface-bearing sealing clamps.

All **SD 4000** Couplings are designed to be installed with a pre-set torque wrench calibrated at 80 inch pounds to accommodate the 305 stainless steel 3/8" Hex Head screw.

1001 El Camino Ave. Corona, CA 92879 Phone: (951) 372-2732 Fax: (951) 738-1183

www.anaco-husky.com



HUSKY® 4101-4102 COUPLING FOR HUBLESS TO COPPER JOINTS

Product Information Submittal

Test	Gasket Physical Test Min. or Max Requirements	ASTM Method
Tensile Strength	1500 psi min.	D 412
Elongation	250 min.	D 412
Durometer [Shore A]	70 ±5 @ 76° F ± 5°F.	D 2240
Accelerated Aging	15% max. tensile and 20% max. elongation deterioration, 10 points max. increase in hardness, all determinations after oven aging for 96 hours at 158°F	D 573
Compression Set	15% max. after 22 hours at 158°F	D 395 method B
Oil Immersion	80% max. volume change after immersion in ASTM oil no. 3 for 70 hours at 212°F	D471
Ozone Cracking	No visible cracking at 2 times magnification of the gasket after 100 hours exposure in 1.5ppm ozone concentration at 100°F. Testing and inspection to be on gasket which is loop mounted to give approximately 20% elongation of outer surface.	D 1149
Tear Resistance	Die C; 150 lbs., min. per inch of thickness	D 624
Water Absorption	20% max by weight after 7 days at 158°F	D 471

Materials

- Clamp: Type 304 AISI stainless steel.
- Screw: Type 305 AISI stainless steel 3/8" hex head/shoulder
- Shield: Type 304 AISI stainless steel, corrugated. Shield thickness .016
- Gasket: The gasket shall be fabricated from a compound containing high quality neoprene as the sole elastomer. ASTM C 564.

} ———— ASTM C 1277
} ———— ASTM C 1540

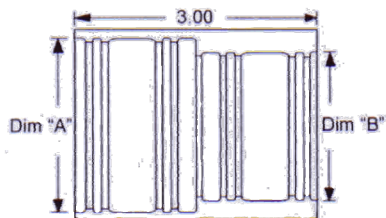
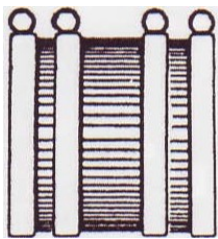

Application Data

Model	Dim "A"	Dim "B"
4101	2" CI	1 ½" Copper
4102	2" CI	2" Copper

The **HUSKY SD 4101 & 4102** is a heavy-duty all stainless steel transition coupling to connect cast iron Hubless pipe and fittings to Copper pipe. This has been accomplished by manufacturing our coupling with a heavy duty corrugated shield of sufficient width to accommodate additional surface-bearing sealing clamps.

The couplings consist of a 3" wide corrugated 304 stainless steel shield in conjunction with four stainless steel clamps mounted in a series, secured in place by means of a fixed and "floating" eyelet to allow the clamp "travel" during tightening. Couplings are designed to be installed with a pre-set torque wrench calibrated at 80 inch pounds, to accommodate the stainless steel 3/8" Hex Head/Shoulder screw.

Meets ASTM C 1460 standard.

1001 El Camino Ave. Corona, CA 92879 Phone: (951) 372-2732 Fax: (951) 738-1183

www.anaco-husky.com

INSTALLATION SUGGESTIONS

FOR THE ANACO SD 4000 NO HUB® COUPLING

Purpose

These suggestions provide guidelines for the use of **anaco HUSKY® SD 4000** Coupling for joining No-Hub® pipe and fitting in accordance with accepted industry standards and practices. All construction projects involve many variables. Governing codes, engineering criteria, and the conventions of the plumbing trade necessitate that judgment decisions must be a combination of design and "on the job" considerations. The following suggestions for joining No-Hub® pipe and fittings with the **anaco HUSKY®** coupling are not definitive but it is hoped that they will be helpful.

Installation Instructions

A properly calibrated torque wrench set at 80-inch pounds should always be used when installing **HUSKY®** couplings. When power tools are used to install **HUSKY®** couplings they should be adjusted or calibrated to torque only to 80-inch pounds.

1-1/2" thru 4"

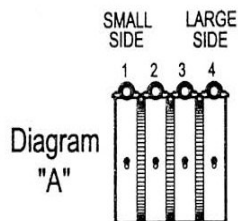

5" thru 10"

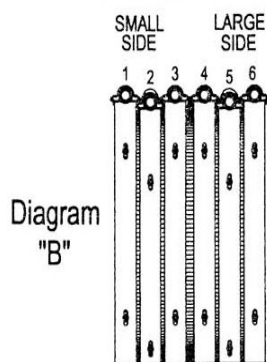

1. In order to provide a sound joint with field cut lengths of pipe, the ends should be cut square. Place the Neoprene gasket on the end of one pipe and the stainless steel clamp assembly on the other end of the other pipe or fitting to be joined.
2. Firmly seat both ends of the pipe/fitting against the internally molded shoulder in the center of the gasket.
3. Slide the clamp assembly into position centered over the gasket.
4. **HUSKY** couplings 1 1/2", 2", 3" and 4" are three inches wide and have four sealing bands. Tighten bands to 80-inch pounds in the following sequence. Starting on the side of the joint with the smaller diameter (see diagram "A") torque as follows: 2,1 - 2,1 - 3,4 - 2,1 - 3,4.
5. **HUSKY** couplings 5", 6", 8" and 10" are four inches wide and have six sealing bands. Tighten bands to 80-inch pounds in the following sequence. Starting on the side of the joint with the small diameter, (see diagram B) torque as follows: 3,2,1 - 3,2,1, - 4,5,6 - 4,5,6 - 2,1 - 4,5,6.
6. Once the coupling is installed and torqued to 80-inch pounds in this torque pattern it is no necessary to go back and re-torque the couplings.

*****HUSKY®** Technologies has intentionally color coated the **HUSKY®** 304 Stainless Steel Shield. The Orange shield identifies this product as genuine **anaco HUSKY®** Heavy Duty Coupling. Husky's performance, including its exceptional sealing ability, corrosion resistance, deflection and rigidity has not been compromised in any way. **Rev. 3-15-03**

1001 El Camino Ave. Corona, CA 92879 Phone: (951) 372-2732 Fax: (951) 738-1183

www.anaco-husky.com



HUSKY® HD 2000

List Prices

HD- 711NAT July 1, 2011

Part Number	Coupling Size	Carton Quantity	Carton Weight	List Price
2002	1½"	60	29	15.50
2006	2"	75	41	16.55
2008	3"	48	32	19.00
2010	4"	48	39	22.10
2012	5"	15	23	45.60
2014	6"	15	26	51.90
2016	8"	15	31	107.15
2017	10"	12	30	137.60
Reducing Couplings	Coupling Size	Carton Quantity	Carton Weight	List Price
2004	2 x 1½"	36	26	18.65
2005	3x2	24	26	26.80
2009	4x3	15	21	32.15
2013	4x2	15	27	38.60
Transition Couplings	Coupling Size	Carton Quantity	Carton Weight	List Price
2101	2 x 1½"	24	18	22.80
2102	2 x 2	24	15	21.75

Terms: 2% 10th prox., net thereafter.

Full freight is allowed on all orders of \$2500 or 600 or more pieces.

Prices subject to change without notice.

Return goods restocking charge of 25% subject to factory charge authorization.

Orders will be subject to a 10% premium on broken case quantities only.



1001 El Camino Ave. Corona, CA 92879 Phone: (951) 372-2732 Fax: (951) 738-1183

www.anaco-husky.com



HUSKY® SERIES 2000 COUPLING

Product Information Submittal



Certifications & Standards

- Meets ASTM C 1540
- Meets ASTM C 564
- Meets FM 1680 Class 1
- Meets CSA B 602
- lapmo File 6726

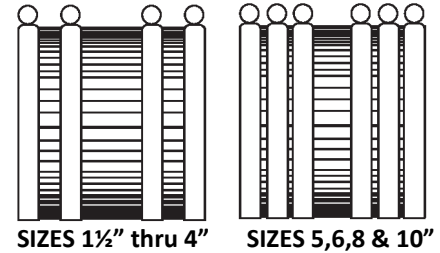

SIZES 1½" thru 4"

SIZES 5,6,8 & 10"

Size	Width	No. of Straps	Torque
1 ½" - 4"	3.0	4	80
5 & 6	4.0	6	80
8 & 10	4.0	6	80

Material Specifications

Clamp: Type 304 AISI Stainless steel

Screw: Type 305 AISI stainless steel 5/16

Shield: Type 304 AISI stainless steel, corrugated. Shield thickness 0.010

Gasket: The gasket shall be manufactured from a properly vulcanized virgin compound in which the primary elastomer is polychloroprene (neoprene) conforming to ASTM C 564. Oil Immersion test: 80% max. Volume Change after immersion in ASTM oil no. 3 for 70 hours at 212°F.

The **HUSKY HD 2000** Coupling has been engineered by **anaco** to provide a heavy duty, all stainless steel coupling, balancing the desire for a more rigid joint with the need to provide a superior positive seal, which can accommodate possible disparities in the mating of No-Hub pipe and fittings. This has been accomplished by manufacturing our coupling with a super-duty corrugated shield of sufficient width to accommodate additional surface-bearing sealing clamps.

The additional sealing clamps when torqued to 80 inch pounds, offer two salient performance related features. First, the overall dimensional thickness of the clamp and shield, in conjunction with the additional width of the coupling, result in a more uniformly rigid joint, with the load being supported at both the outer edge of the coupling and the centerline of the joint. Second, the additional sealing clamps yield increased surface-bearing contact between the coupling and the pipe or fittings, thereby inhibiting joint movement at higher internal pressures not commonly associated with a DWV system.

The 1½" through 4" diameter couplings consist of a 3" wide corrugated 304 stainless steel shield in conjunction with four (4) stainless steel clamps mounted in a series, secured in place by means of affixed and "floating" eyelet to allow the clamp "travel" during tightening.

The 5" through 10" diameter couplings consist of a 4" wide corrugated 304 stainless steel shield in conjunction with six (6) stainless steel clamps mounted in a series, secured in place by means of affixed and "floating" eyelet to allow the clamp "travel" during tightening.

All **HD 2000** Couplings are designed to be installed with a pre-set torque wrench calibrated at 80 inch pounds to accommodate the 305 stainless steel 3/8" Hex Head screw.

1001 El Camino Ave. Corona, CA 92879 Phone: (951) 372-2732 Fax: (951) 738-1183

www.anaco-husky.com



HUSKY® 2000 REDUCER COUPLING

Product Information Submittal

Test	Physical Tests Min. or Max Requirements	ASTM Method
Tensile Strength	1500 psi min.	D 412
Elongation	250 min.	D 412
Durometer [Shore A]	70 +/- 5 @ 76° F +/- 5°F.	D 2240
Accelerated Aging	15% maximum tensile and 20% maximum elongation deterioration, 10 points maximum increase in hardness, all determination after oven aging for 96 hours at 158°F	D 573
Compression Set	25% maximum after 22 hours at 158°F	D 395 method B
Oil Immersion	80% maximum volume change after immersion in IRM 903 for 70 hours at 212°F	D471
Ozone Cracking	No visible cracking at 2 times magnification of the gasket after 100 hours exposure in 1.5ppm ozone concentration at 100°F. Testing and inspection to be on gasket which is loop mounted to give approximately 20% elongation of outer surface.	D 1149
Tear Resistance	150Lbs. Minimum per inch of thickness	D 624
Water Absorption	20% maximum by weight after 7 days at 158°F	D 471

Materials

- Clamp: Type 304 AISI stainless steel.
- Screw: Type 305 AISI stainless steel 5/16"
- Shield: Type 304 AISI stainless steel, corrugated. Shield thickness .010
- Gasket: The gasket shall be manufactured from a properly vulcanized virgin compound in which the primary elastomer is polychloroprene (neoprene) conforming to ASTM C 564

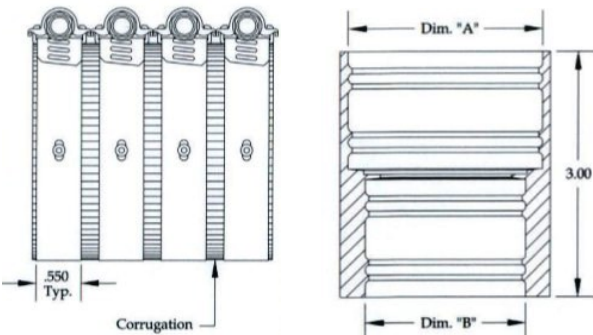

Application Data

Model	Size
2004	2"x1½"
2005	3"x2"
2009	4"x3"
2013	4"x2"

Certifications & Standards

- Meets ASTM C 1540
- Meets ASTM C 564
- Iapmo File 6726

The **HUSKY HD 2000** Coupling has been engineered by **anaco** to provide a heavy duty, all stainless steel coupling, balancing the desire for a more rigid joint with the need to provide a superior positive seal, which can accommodate possible disparities in mating of No-Hub pipe and fittings. This has been accomplished by manufacturing our coupling with a super-duty corrugated shield of sufficient width to accommodate additional surface-bearing sealing clamps. All **HD 2000** Couplings are designed to be installed with a pre-set torque wrench calibrated at 80 inch pounds to accommodate the 305 stainless steel 5/16" Hex Head screw.

1001 El Camino Ave. Corona, CA 92879 Phone: (951) 372-2732 Fax: (951) 738-1183

www.anaco-husky.com



HUSKY® 2101-2102 COUPLING FOR HUBLESS TO COPPER JOINTS

Product Information Submittal

Test	Gasket Physical Test Min. or Max Requirements	ASTM Method
Tensile Strength	1500 psi min.	D 412
Elongation	250 min.	D 412
Durometer [Shore A]	70 ±5 @ 76° F ± 5°F.	D 2240
Accelerated Aging	15% max. tensile and 20% max. elongation deterioration, 10 points max. increase in hardness, all determinations after oven aging for 96 hours at 158°F	D 573
Compression Set	15% max. after 22 hours at 158°F	D 395 method B
Oil Immersion	80% max. volume change after immersion in ASTM oil no. 3 for 70 hours at 212°F	D471
Ozone Cracking	No visible cracking at 2 times magnification of the gasket after 100 hours exposure in 1.5ppm ozone concentration at 100°F. Testing and inspection to be on gasket which is loop mounted to give approximately 20% elongation of outer surface.	D 1149
Tear Resistance	Die C; 150 lbs., min. per inch of thickness	D 624
Water Absorption	20% max by weight after 7 days at 158°F	D 471

Materials

- Clamp: Type 304 AISI stainless steel.
 - Screw: Type 305 AISI stainless steel 5/16" hex head/shoulder
 - Shield: Type 304 AISI stainless steel, corrugated. Shield thickness .010
 - Gasket: The gasket shall be fabricated from a compound containing high quality neoprene as the sole elastomer. ASTM C 564.
- } ——— ASTM C 1277
 } ——— ASTM C 1540

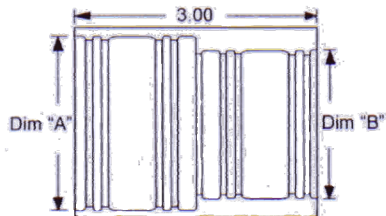
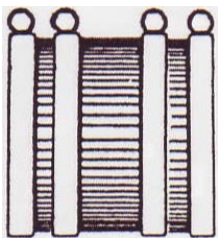

Application Data

Model	Dim "A"	Dim "B"
2101	2" CI	1 ½" Copper
2102	2" CI	2" Copper

The **Husky HD 2101 & 2102** is a heavy-duty all stainless steel transition coupling to connect cast iron Hubless pipe and fittings to Copper pipe. This has been accomplished by manufacturing our coupling with a heavy duty corrugated shield of sufficient width to accommodate additional surface-bearing sealing clamps.

The couplings consist of a 3" wide corrugated 304 stainless steel shield in conjunction with four stainless steel clamps mounted in a series, secured in place by means of a fixed and "floating" eyelet to allow the clamp "travel" during tightening. Couplings are designed to be installed with a pre-set torque wrench calibrated at 80 inch pounds, to accommodate the stainless steel 5/16" Hex Head/Shoulder screw.

Meets ASTM C 1460 standard.

INSTALLATION SUGGESTIONS

FOR THE ANACO HD 2000 NO HUB® COUPLING

Purpose

These suggestions provide guidelines for the use of **anaco HUSKY® HD 2000** Coupling for joining No-Hub® pipe and fitting in accordance with accepted industry standards and practices. All construction projects involve many variables. Governing codes, engineering criteria, and the conventions of the plumbing trade necessitate that judgment decisions must be a combination of design and "on the job" considerations. The following suggestions for joining No-Hub® pipe and fittings with the **anaco HUSKY®** coupling are not definitive but it is hoped that they will be helpful.

Installation Instructions

A properly calibrated torque wrench set at 80-inch pounds should always be used when installing **HUSKY®** couplings. When power tools are used to install **HUSKY®** couplings they should be adjusted or calibrated to torque only to 80-inch pounds.

1-1/2" thru 4"

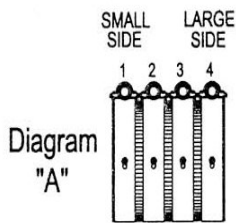

5" thru 10"

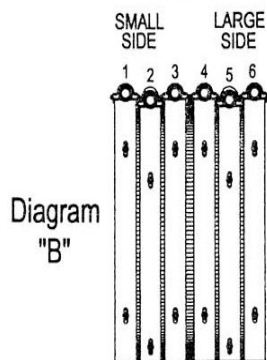

1. In order to provide a sound joint with field cut lengths of pipe, the ends should be cut square. Place the Neoprene gasket on the end of one pipe and the stainless steel clamp assembly on the other end of the other pipe or fitting to be joined.
2. Firmly seat both ends of the pipe/fitting against the internally molded shoulder in the center of the gasket.
3. Slide the clamp assembly into position centered over the gasket.
4. **HUSKY** couplings 1 1/2", 2", 3" and 4" are three inches wide and have four sealing bands. Tighten bands to 80-inch pounds in the following sequence. Starting on the side of the joint with the smaller diameter (see diagram "A") torque as follows: 2,1 - 2,1 - 3,4 - 2,1 - 3,4.
5. **HUSKY** couplings 5", 6", 8" and 10" are four inches wide and have six sealing bands. Tighten bands to 80-inch pounds in the following sequence. Starting on the side of the joint with the small diameter, (see diagram B) torque as follows: 3,2,1 - 3,2,1, - 4,5,6 - 4,5,6 - 2,1 - 4,5,6.
6. Once the coupling is installed and torqued to 80-inch pounds in this torque pattern it is no necessary to go back and re-torque the couplings.

*****HUSKY®** Technologies has intentionally color coated the **HUSKY®** 304 Stainless Steel Shield. The White shield identifies this product as genuine **anaco HUSKY®** Mid-Range Coupling. Husky's performance, including its exceptional sealing ability, corrosion resistance, deflection and rigidity has not been compromised in any way. **Rev. 3-15-03**

1001 El Camino Ave. Corona, CA 92879 Phone: (951) 372-2732 Fax: (951) 738-1183

www.anaco-husky.com

SERVICE WEIGHT GASKET

List Prices

SWG-711NAT July 1, 2011

ANACO Ty Seal Part #	ANACO EZ Tite Part #	Size	List Price	Carton Quantity	Weight Per carton
3002	3102	2"	\$ 7.85	60	18 lbs.
3003	3103	3"	\$ 10.25	40	16 lbs.
3004	3104	4"	\$12.80	40	24 lbs.
3005	3105	5"	\$19.70	30	35 lbs.
3006	3106	6"	\$20.35	30	40 lbs.
3008	N/A	8"	\$44.70	20	30 lbs.
3010	N/A	10"	\$68.00	10	18 lbs.
3012	N/A	12"	\$86.70	10	22 lbs.
3015	N/A	15"	\$103.75	10	38 lbs.

We reserve the right to withdraw this sheet without notice and price in effect at time of shipment will apply.

Possession of this list price sheet shall not be construed as an offer to sell.

Freight: Prepaid on all orders of 750 pieces or more



1001 El Camino Ave. Corona, CA 92879 Phone: (951) 372-2732 Fax: (951) 738-1183

www.anaco-husky.com



Description:

Ez-Tight is a one-piece compression gasket. It is used for joining hub and spigot cast iron soil pipe and fittings made according to ASTM A 74.

Gasket Specification:

Ez-Tight gaskets conform strictly to ASTM Standard C 564, latest issue.

Joint Characteristics:

Gasket joints will not leak even if deflected as much as 5 degrees, or when subjected to vibration, seismic tremors, expansion, contraction, external or internal test pressure.

Physical Properties

Property	Performance			ASTM Test Method
Hardness (nominal durometer ± 5) as specified by the pipe manufacturer	50	60	70	D2240
Elongation, min, percent	350	300	250	D412
Tensile strength, min, psi (MPa)	1500 (10)	1500 (10)	1500 (10)	D412
Tear Resistance, min, lbf/in. (N/cm)	150 (268)	150 (268)	150 (268)	D624
Compression set, max, percent	25	25	25	D395
Heat aging, 96 h at 158° \pm 2° F (70° \pm 1° C)				D573
Hardness, increase, max, durometer points	10	10	10	—
Loss in tensile strength, max, percent	15	15	15	—
Loss in elongation, max, percent	20	20	20	—
Water absorption: Weight increase, max, percent	20	20	20	D471 —
Ozone resistance Oil immersion: Volume increase, max, percent	no cracks 80	no cracks 80	no cracks 80	D1149 D471

SV EZ-TIGHT GASKETS

Size	Unit	Carton	Carton
2	.3	60	18
3	.4	40	16
4	.6	40	24
5	1.2	30	35
6	1.4	30	40

Bracing:

To prevent movement, horizontal pipe and fittings 5" and larger should be suitably braced by the use of blocks, rdding or other suitable methods at every branch or change of direction.

Test:

For best results, test one floor (ten feet) at a time. The system should be properly restrained; all bends, changes of direction and ends of runs should be restrained.

Gasket Material:

Ez-Tight gaskets are made of Neoprene as the sole elastomer. The physical characteristics of the Neoprene ensure that the gasket will not decay or deteriorate from contact with effluents in the pipe or chemicals in the soil or air around the pipe.

How to Specify:

All 2-inch through 6-inch hub and spigot cast iron soil pipe and fittings shall conform to ASTM A 74; joints shall be made either by caulked lead and oakum or by compression gaskets which conform to ASTM C 564.

SUBMITTAL: TY-SEAL GASKETS, HUB & SPIGOT CAST IRON SOIL PIPE & FITTINGS



DESCRIPTION

TY-SEAL is one-piece compression gasket. It is used for joining hub and spigot cast iron soil pipe and fittings made according to ASTM A 74

GASKET MATERIAL

TY-SEAL gaskets are made of Neoprene as the sole elastomer. The physical characteristics of the Neoprene ensure that the gasket will not decay or deteriorate from contact with effluents in the pipe or chemicals in the soil or air around the pipe.

GASKET SPECIFICATION

TY-SEAL gaskets conform strictly to ASTM Standard C 564, latest issue. The TY-SEAL mill specification meets or exceeds all requirements

PIPE SPECIFICATION

TYLER hub and spigot cast iron soil pipe and fittings comply with the latest issue of ASTM A 74, ANSI A 112.5.1 and Federal Specification WW-P-401E.

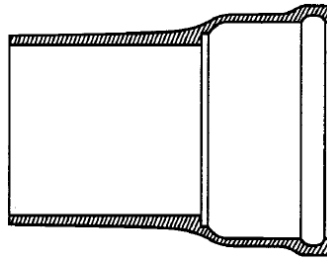

1. Clean hub and spigot to be joined.

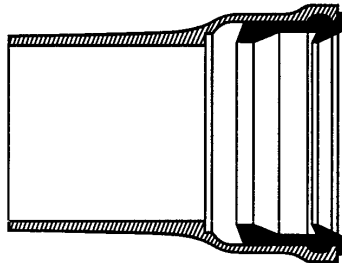

2. Insert gasket in the hub, lubricate inside the gasket.

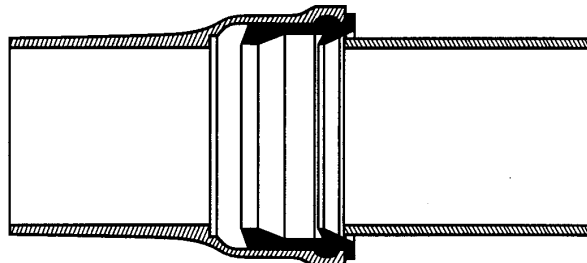

3. Align hub and spigot.

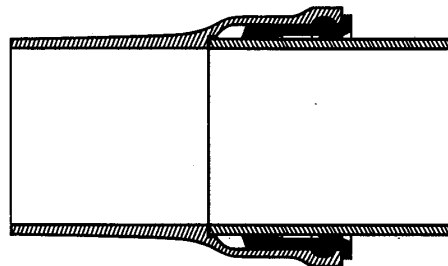

4. Pull or push spigot through the gasket until firmly sealed.

CREMCO SPECIALTY TRANSITION COUPLINGS

List Prices

**CT-710NAT
August 1, 2011**

Part Number	Code	Size / Description	Price Each	Carton Qty / Weight #
CP150	5010-C	1½"CI/PL/ST - 1½"CI/PL/ST	\$5.30	24 / 7
CP200	5020-C	2"CI/PL/ST - 2"CI/PL/ST	\$5.30	24 / 9
CP215	5023-C	1½"CI/PL/ST - 2"CI/PL/ST	\$7.20	24 / 12
CP33	5030-C	3" PL/ST/X - 3"CI	\$8.05	24 / 12
CP43	5041-C	3" PL/ST/X - 4"CI	\$11.40	24 / 16
CP44	5040-C	4" PL/ST/X - 4"CI	\$8.80	24 / 18
CP55	5050-C	5" PL/ST/X - 5"CI	\$18.60	20 / 25
CP66	5060-C	6" PL/ST/X - 6"CI	\$24.85	20 / 32
CP88	5080-C	8" PL/ST/X - 8"CI	\$33.85	10 / 29
CK110	5014-C	¾"PL/ST,1"K - 1½"CI/PL/ST	\$9.80	24 / 10
CK1125	5012-C	1"PL/ST,1¼"K - 1½"CI/PL/ST	\$8.70	24 / 9
CK115	5011-C	1¼"PL/ST,1½"K - 1½"CI/PL/ST	\$7.35	24 / 9
CK210	5025-C	¾"PL/ST,1"K - 2"CI/PL/ST	\$9.75	24 / 15
CK2125	5024-C	1"PL/ST,1-1/4"K - 2"CI/PL/ST	\$10.20	24 / 15
CK215	5022-C	1¼"PL/ST,1½"K - 2"CI/PL/ST	\$7.35	24 / 14
CK22	5021-C	2"K - 2"CI/PL/ST	\$9.80	24 / 11
CK315	5033-C	1¼"PL/ST,1½"K - 3"CI/PL/ST	\$10.80	24 / 24
CK32	5031-C	2"K - 3"CI	\$10.80	24 / 21
CK33	5032-C	3"K - 3"CI	\$10.30	24 / 15
CK42	5042-C	2"K - 4"CI	\$14.80	24 / 22
CK43	5043-C	3"K - 4"CI	\$10.95	24 / 28
CK44	5044-C	4"K - 4"CI	\$10.80	24 / 18
C315	5310-C	1½"CI/PL/ST - 3"CI	\$11.10	24 / 22
C320	5311-C	2"CI/PL/ST - 3"CI	\$10.45	24 / 22
C420	5410-C	2"CI/PL/ST - 4"CI	\$13.75	24 / 35
C430	5411-C	3"CI - 4"CI	\$12.65	24 / 26
C540	5501-C	4"CI - 5"CI	\$18.25	20 / 25
C640	5602-C	4"CI - 6"CI	\$26.75	20 / 30
P100	5105-C	1"PL/ST,1-1/4K - 1"PL/ST,1-1/4K	\$5.70	24 / 6
P300	5304-C	3"PL/ST/X - 3"PL/ST/X	\$8.70	24 / 10

1001 El Camino Ave. Corona, CA 92879 Phone: (951) 372-2732 Fax: (951) 738-1183

www.anaco-husky.com

P400	5405-C	4"PL/ST/X - 4"PL/ST/X	\$10.80	24 / 15
P430	5406-C	3"PL/ST/X - 4"PL/ST/X	\$12.15	24 / 25
P600	5601-C	6"PL/ST/X - 6"PL/ST/X	\$18.45	20 / 30
P800	5801-C	8"PL/ST/X - 8"PL/ST/X	\$31.40	10 / 20
PC32	5305-C	3"CI/PL/ST - 3"PL/ST/X	\$9.80	24 / 10
PC43	5407-C	3"CI - 4"PL/ST/X	\$12.45	24 / 25
PK33	5306-C	3"K - 3"PL/ST/X	\$10.70	24 / 15
K150	5106-C	ST X 1¼"PL/ST,1½"K - 1¼"PL/ST,1½K	\$5.90	24 / 8
K200	5206-C	2"K - 2"K	\$6.50	24 / 8
K215	5207-C	2"K - 1¼"PL/ST,1½K	\$10.60	24 / 15
K300	5307-C	3"K - 3"K	\$8.50	24 / 10
K320	5308-C	3"K - 2"K	\$11.50	24 / 24
K400	5408-C	4"K - 4"K	\$10.50	24 / 15
KC215	5208-C	1½"CI/PL/ST - 2"K	\$8.60	24 / 15
KC32	5309-C	2"CI/PL/ST - 3"K	\$10.85	24 / 22
KC43	5409-C	3"CI - 4"K	\$14.30	24 / 30
KT150	5107-C	1½"TU - 1¼"PL/ST,1½"K	\$7.75	24 / 10
KT215	5209-C	1½"TU - 2"K	\$10.75	24 / 15
T150	5108-C	1½"TU - 1½"CI/PL/ST	\$8.70	24 / 9
T215	5210-C	1½"TU - 2"CI/PL/ST	\$8.70	24 / 15
BWT150	5109-C	1½"TU - 1½"TU	\$8.00	24 / 11
TWC43	5412-C	3"CI - 4"TWP	\$14.10	24 / 28
TWC44	5413-C	4"CI - 4"TWP	\$9.40	24 / 18
TWP43	5414-C	3"PL/ST/X - 4"TWP	\$10.90	24 / 28
TWP44	5415-C	4"PL/ST/X - 4"TWP	\$11.80	24 / 18

We reserve the right to withdraw this sheet without notice and price in effect at time of shipment will apply. Possession of this list price sheet shall not be construed as an offer to sell. Freight: Prepaid on all orders of 750 or more





TRANSITION COUPLINGS SUBMITTAL

CERTIFICATIONS AND STANDARDS

- Meets ASTM C- 1460
- Meets ASTM C - 564
- Meets CSA B602
- IAPMO File 5794

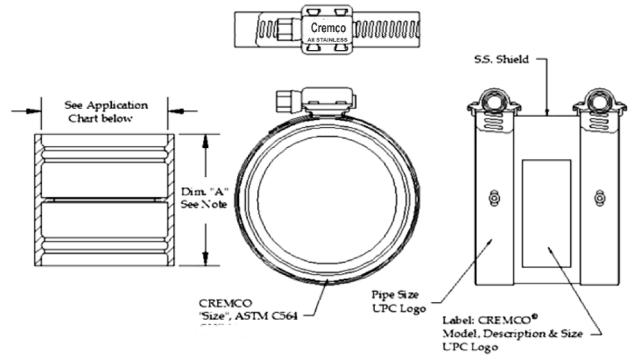

MATERIAL SPECIFICATION

- **CLAMP:** Type 301 AISI Stainless Steel
- **SCREW:** Type 305 AISI Stainless Steel
- **SHIELD:** Type 301 AISI Stainless Steel. Shield thickness .0072"
- **GASKET:** The gasket shall be manufactured from a properly vulcanized virgin compound, in which the primary elastomer is polychloroprene (Neoprene), conforming to ASTM C-564.

TEST	GASKET PHYSICAL TEST MIN. or MAX REQUIREMENTS	ASTM METHOD
Tensile Strength	1500 psi min.	D 412
Elongation	250 min.	D 412
Durometer (Shore A)	70 ± 5 @ 76° F ± 5° F	D 2240
Accelerated Aging	15% max. tensile and 20% max. elongation deterioration, 10 points max. increase in hardness, all determinations after oven aging for 96 hrs at 158° F	D 573
Compression Set	25% maximum after 22 hrs at 158° F	D 395 (Method B)
Oil Immersion	80% max. volume change after immersion in IRM 903 for 70 hrs at 212° F	D 471
Ozone Cracking	No visible cracking at 2x magnification of the gasket after 100 hrs of exposure in 1.5ppm ozone concentration at 100°F. Testing and inspection to be on gasket which is loop mounted to give approx. 20% elongation on outer surface.	D 1149
Tear Resistance	150 lbs minimum per inch thickness	D 624
Water Absorption	20% max by weight after 7 days at 158° F	D 471

1001 El Camino Ave. Corona, CA 92879 Phone: (951) 372-2732 Fax: (951) 738-1183

www.anaco-husky.com

anaco®CAP**List Prices**

TC-607NAT
June 1, 2007

Caps off Plastic, Cast Iron, NO-HUB,
 Steel Pipe or Closet Bends
 300 series all stainless steel worm drive screw and
 clamp assembly. Non-removable "Blow out Guard" built
 into body of cap. Materials conform to
 Cast Iron Soil Pipe Institute physical requirements spec. 301.
 Installs with screw driver or NO-HUB torque wrench

Code	Size	List Price	Quantity Per Carton	Weight Per carton
9329	1 1/2"	\$2.35	100	15.00 lbs.
9330	2"	\$2.35	100	17.75 lbs.
9331	3"	\$3.15	100	32.50 lbs.
9332	4"	\$3.55	50	22.25 lbs.

We reserve the right to withdraw this sheet without notice and price in effect at time of shipment will apply

Possession of this list price sheet shall not be construed as an offer to sell.

Freight: Prepaid on all orders of 750 or more



RIGID QUIK

List Prices

RQ-408NAT April 1, 2008

Code #	Size/Description	LIST	CARTON QTY
6010	1-1/2 CI, Plastic-1-1/4 Copper	\$19.90	24
6011	1-1/2 CI,Plastic - 1 1/2 CI Plastic	\$12.80	24
6012	1-1/2 CL,Plastic - 1 1/2 Copper, 1 1/4 Plastic	\$19.90	24
6020	2 CI Plastic - 1 1/4 Copper	\$24.50	18
6021	2 CI, Plastic - 1 1/2 CI Plastic	\$14.70	18
6022	2 CI, Plastic - 1 1/ 2 Copper, 1 1/4 Plastic	\$19.90	18
6023	2 CI, Plastic - 2 CI, Plastic	\$12.80	50
6024	2 CI, Plastic - 2 Copper	\$26.50	18
6030	3 CI, Plastic - 1 1/4 Copper	\$26.50	32
6031	3 CI, Plastic - 1 1/2 CI, Plastic	\$28.75	32
6032	3 CI, Plastic - 1 1/2 Copper, 1 1/4 Plastic	\$28.75	32
6033	3 CI, Plastic - 2 CI, Plastic	\$21.50	32
6034	3 CI, Plastic - 2 Copper	\$26.50	32
6035	3 CI, Plastic - 3 CI, Plastic	\$14.80	32
6036	3 CI, Plastic - 3 Copper	\$24.30	32
6040	4 CI, Plastic - 2 CI, Plastic	\$30.90	18
6041	4 CI, Plastic - 3 CI, Plastic	\$26.50	18
6042	4 CI, Plastic - 3 Copper	\$28.75	18
6043	4 CI, Plastic - 4 CI, Plastic	\$18.50	18

We reserve the right to withdraw this sheet without notice and price in effect at time of shipment will apply. Possession of this price sheet shall not be construed as an offer to sell.

Freight: Prepaid on all orders of 750 pieces or more



1001 El Camino Ave. Corona, CA 92879 Phone: (951) 372-2732 Fax: (951) 738-1183

www.anaco-husky.com



RIGID QUIK COUPLINGS SUBMITTAL

APPLICABLE PIPING STANDARDS

- Cast Iron - ASTM A 888/CISPI 301
- Copper DWV– ASTM B 306
- ABS DWV - ASTM D 2661 & ASTM F 628
- PVC DWV - ASTM D 2665 & ASTM F 891

MATERIAL SPECIFICATION

- CLAMP: Stainless steel hose clamps are 300 series
- COUPLING: Injected molded exclusively from Santoprene rubber

COUPLING SPECIFICATIONS

- Clamp: Stainless Quik comply with ASTM C 1461 and CSA B 602
- IAPMO Listing-3251

DESCRIPTION

Cremco Rigid Quik Couplings consist of a molded one-piece Santoprene rubber gasket and 300 series stainless steel hose clamps. The couplings are designated as Rigid Unshielded due to the coupling's ability to provide the required resistance to lateral displacement without the assistance of a metallic shear ring (shield). The couplings are used to join various types and diameters of Drain, Waste, and vent (DWV) pipe and fittings together, above and below ground, inside and outside of the building.

End of Document

