



The new degree of comfort.™

Rheem *Classic*® Series Package Gas Electric Unit



RGEA14- 14 SEER Series

Nominal Sizes 2-5 Tons [7.0-17.6 kW]

RGEA15- 15 SEER Series

Nominal Sizes 2-5 Tons [7.0-17.6 kW]



TABLE OF CONTENTS

Unit Features & Benefits	3-4
Model Number Identification	5
Available SKUs	5
Options	6
General Data	
RGEA14- Series	7-26
RGEA15- Series	27-49
General Data Notes	50
Gross Systems Performance Data	
RGEA14- Series	51-56
RGEA15- Series	57-62
Indoor Airflow Performance	
RGEA13- Series	63-68
RGEA15- Series	69-72
Electrical Data	
RGEA14- Series	73-81
RGEA15- Series	82-91
Dimensional Data	92-93
Typical Installations	94
Accessories	95-102
Limited Warranty	103

Package Gas Electric Unit Features:

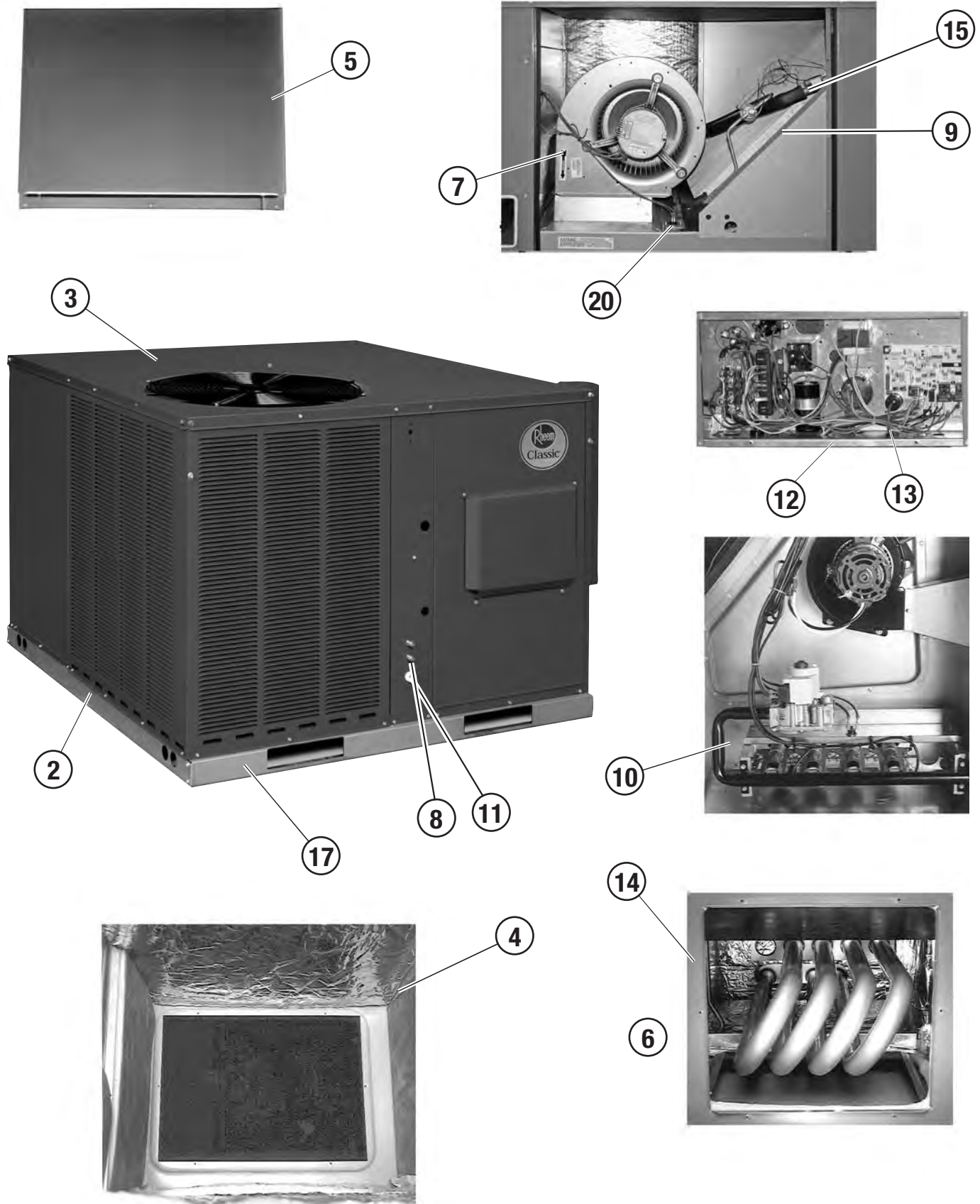



RGEA14/15 Features Below Correspond to Photos on Page 3

1. All models feature Scroll® compressors for maximum efficiency and quiet operation. 5 Ton RGEA15 models feature UltraTech™ Scroll 2-Stage compressors with Comfort Alert™ diagnostics (see below), high/low pressure switches, and hard start kits.
2. Louvered condenser compartment for protecting the coil against yard hazards and/or weather extremes.
3. One-piece top with a deep flange to help keep water out of the unit.
4. Supply and return air openings feature a one-inch tall flange to prevent water migration into the ductwork.
5. Access panels have “weep holes” and channels to further help manage water run-off.
6. Side and down discharge options available on all models. All models are shipped ready for horizontal application.
7. Easily accessible blower section complete with slide-out blower.
8. Refrigerant connections are conveniently located for easy service diagnostics.
9. Micro Channel evaporator and condenser delivers superior performance with less refrigerant charge and less weight than conventional copper tube/aluminum fin coils. In addition the all aluminum construction has superior protection against formicary corrosion and aluminum tube rubbing potential. Its easier to clean and has a more robust surface.
10. Inside the easily accessible furnace compartment is the draft inducer motor. This motor is specially designed for quiet reliable operation. In addition to the draft inducer motor, the in-shot gas burners and manifold efficiently regulate the flow of gas for combustion. These new gas/electric units also feature direct-spark ignition and remote flame sensors for added reliability and efficiency.
11. All units feature an internal trap on the condensate line eliminating the need for installing an on-site external trap.
12. Easily accessible control box.
13. Single point wiring simplifies installation.
14. Our gas/electric package units feature a tubular heat exchanger design. Tubular heat exchangers are more efficient and durable than older-style clamshell heat exchangers. The heat exchanger is backed by a 10 year limited warranty. Models with a stainless steel heat exchanger installed in a residential application are backed by a limited lifetime warranty.
15. Thermal expansion valve standard on all models for superior superheat control, reliability, and energy efficiency at all operating conditions.
16. Filter drier standard on all models (not shown).
17. Rugged baserail included for improved installation and handling
18. Complete factory charged, wired and run tested.
19. Molded compressor plugs.
20. A double sloped evaporator coil drain pan assures all water is removed from the unit to improve indoor air quality.

Comfort Alert™ Diagnostics – Faster Service And Improved Accuracy (2-Stage Models Only)

The Comfort Alert™ diagnostics module is a breakthrough innovation for troubleshooting air conditioning system failures. The module is installed in the control box near the compressor contactor. By monitoring and analyzing data from the Scroll® compressor and the thermostat demand, the module can accurately detect the cause of electrical and system related failures without any sensors. A flashing LED indicator communicates the ALERT code and guides the service technician more quickly and accurately to the root cause of a problem.

NOTE: Single phase module does not provide safety protection! The Comfort Alert module is a monitoring device and cannot control or shut down the compressor unless used with a White Rodgers IF95-CA397 Thermostat.

NOTE: Three phase module provides compressor protection and will shut down the compressor when compressor damaging conditions are detected.



R GE A 14 036 A J D 10 1 A A X X X

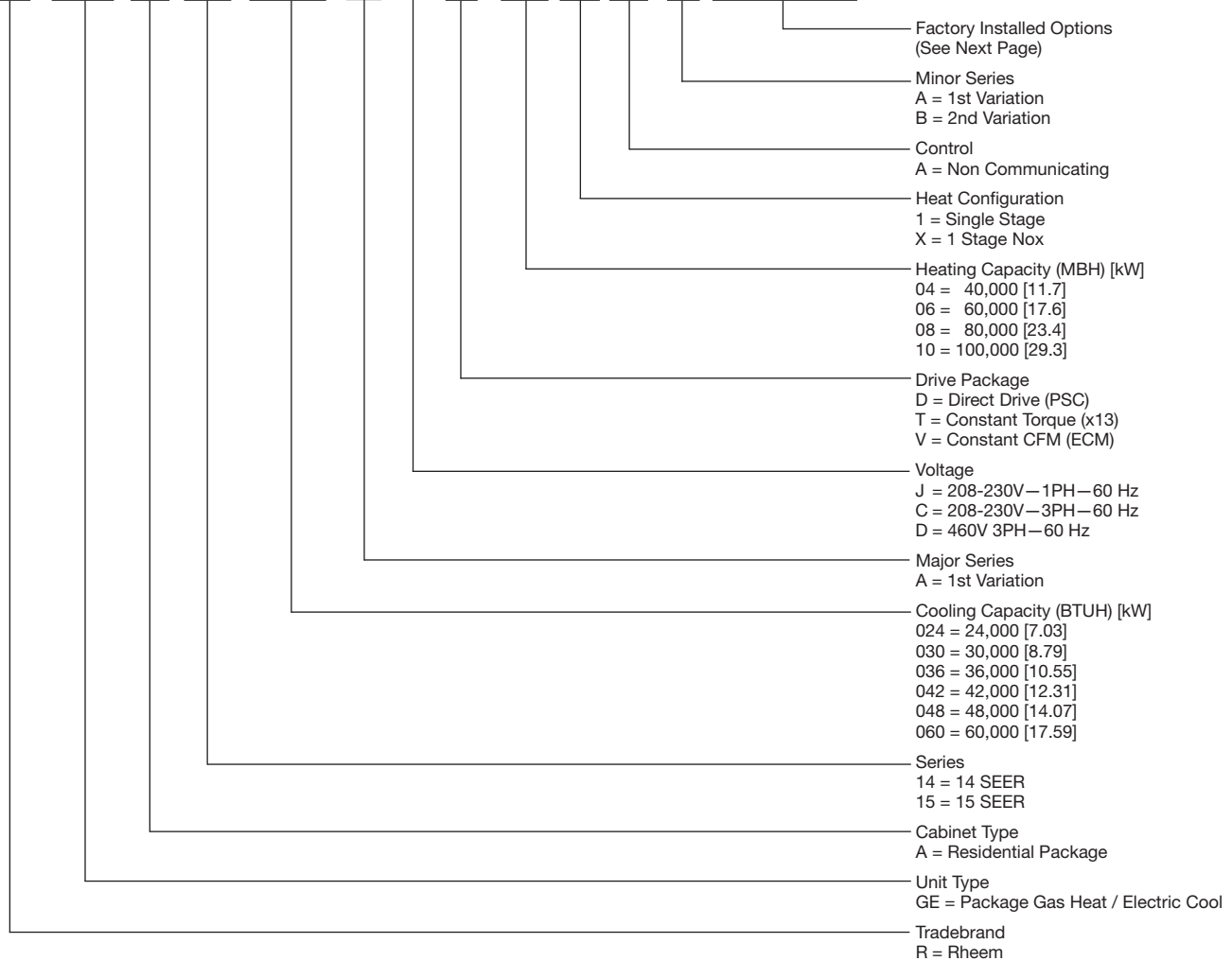

[] Designates Metric Conversions

Available SKUs

Available Models					
RGEA14			RGEA15		
RGEA14024AJT061AB	RGEA14036ADD08XAA	RGEA14048ACT081AA	RGEA15024AJV061AB	RGEA15036ADT08XAA	RGEA15048ACT081AA
RGEA14024AJT06XAB	RGEA14036ADD101AA	RGEA14048ACT08XAA	RGEA15024AJV06XAB	RGEA15036ADT101AA	RGEA15048ACT08XAA
RGEA14024AJT081AB	RGEA14036ADD10XAA	RGEA14048ACT101AA	RGEA15024AJV081AB	RGEA15036ADT10XAA	RGEA15048ACT101AA
RGEA14024AJT08XAB	RGEA14036AJT061AB	RGEA14048ACT10XAA	RGEA15024AJV08XAB	RGEA15036AJV061AB	RGEA15048ACT10XAA
RGEA14030AJT061AB	RGEA14036AJT06XAB	RGEA14048ADT101AA	RGEA15030AJV061AB	RGEA15036AJV06XAB	RGEA15048ADT101AA
RGEA14030AJT06XAB	RGEA14036AJT081AB	RGEA14048ADT10XAA	RGEA15030AJV06XAB	RGEA15036AJV081AB	RGEA15048ADT10XAA
RGEA14030AJT081AB	RGEA14036AJT08XAB	RGEA14048AJT081AB	RGEA15030AJV081AB	RGEA15036AJV08XAB	RGEA15048AJV081AB
RGEA14030AJT08XAB	RGEA14036AJT101AB	RGEA14048AJT08XAB	RGEA15030AJV08XAB	RGEA15036AJV101AB	RGEA15048AJV08XAB
RGEA14036ACD061AA	RGEA14036AJT10XAB	RGEA14048AJT101AB	RGEA15036ACT061AA	RGEA15036AJV10XAB	RGEA15048AJV101AB
RGEA14036ACD06XAA	RGEA14042ACT081AA	RGEA14048AJT10XAB	RGEA15036ACT06XAA	RGEA15042ACT081AA	RGEA15048AJV10XAB
RGEA14036ACD081AA	RGEA14042ACT08XAA	RGEA14060ACT101AA	RGEA15036ACT081AA	RGEA15042ACT08XAA	RGEA15060ACT101AA
RGEA14036ACD08XAA	RGEA14042ACT101AA	RGEA14060ACT10XAA	RGEA15036ACT08XAA	RGEA15042ACT101AA	RGEA15060ACT10XAA
RGEA14036ACD101AA	RGEA14042ACT10XAA	RGEA14060ADT101AA	RGEA15036ACT101AA	RGEA15042ACT10XAA	RGEA15060ADT101AA
RGEA14036ACD10XAA	RGEA14042AJT081AB	RGEA14060ADT10XAA	RGEA15036ACT10XAA	RGEA15042AJV081AB	RGEA15060ADT10XAA
RGEA14036ADD061AA	RGEA14042AJT08XAB	RGEA14060AJT101AB	RGEA15036ADT061AA	RGEA15042AJV08XAB	RGEA15060AJV101AB
RGEA14036ADD06XAA	RGEA14042AJT101AB	RGEA14060AJT10XAB	RGEA15036ADT06XAA	RGEA15042AJV101AB	
RGEA14036ADD081AA	RGEA14042AJT10XAB		RGEA15036ADT081AA	RGEA15042AJV10XAB	



Instructions for Factory Installed Option(s) Selection

Note: Three characters following the model number will be utilized to designate a factory-installed option or combination of options. If no factory option(s) is required, nothing follows the model number.

Step 1. After a basic rooftop model is selected, choose a *three-character* option code from the FACTORY INSTALLED OPTION SELECTION TABLE.

FACTORY INSTALLED OPTION CODES

Option Code	Stainless Steel Heat Exchanger	Tin Plated Hairpin Coil
AJA	x	

"x" indicates factory installed option.

Example: No Option

RGEA14036AJD081AA

Example: Option with Stainless Steel Heat Exchanger

RGEA14036AJD081AAAJA

Note: Factory installed economizer is not available on these models.

NOMINAL SIZES 2-5 TONS [7.0-17.6 kW]

Model RGEA14 Series	024AJD041AA	024AJD04XAA	024AJD061AA	024AJD06XAA
Cooling Performance¹				CONTINUED →
EER/SEER ²	11/14	11/14	11/14	11/14
Nominal CFM/AHRI Rated CFM [L/s]	800/900 [378/425]	800/900 [378/425]	800/900 [378/425]	800/900 [378/425]
AHRI Net Cooling Capacity Btu [kW]	23,600 [6.91]	23,600 [6.91]	23,600 [6.91]	23,600 [6.91]
Net Sensible Capacity Btu [kW]	17,790 [5.21]	17,790 [5.21]	17,790 [5.21]	17,790 [5.21]
Net Latent Capacity Btu [kW]	5,810 [1.70]	5,810 [1.70]	5,810 [1.70]	5,810 [1.70]
Net System Power kW	2.1	2.1	2.1	2.1
Heating Performance (Gas)³				
Heating Input Btu [kW]	40,000 [11.72]	40,000 [11.72]	60,000 [17.58]	60,000 [17.58]
Heating Output Btu [kW]	32,000 [9.38]	32,000 [9.38]	48,000 [14.06]	48,000 [14.06]
Temperature Rise Range °F [°C]	25-55 [13.9-30.6]	25-55 [13.9-30.6]	40-70 [22.2-38.9]	40-70 [22.2-38.9]
AFUE % ⁴	81	81	81	81
Steady State Efficiency (%)	82	82	82	82
No. Burners	2	2	2	2
No. Stages	1	1	1	1
Gas Connection Pipe Size in. [mm]	0.5 [12.7]	0.5 [12.7]	0.5 [12.7]	0.5 [12.7]
Compressor				
No./Type	1/Scroll	1/Scroll	1/Scroll	1/Scroll
Outdoor Sound Rating (dB)⁵				
	76	76	76	76
Outdoor Coil—Fin Type				
Tube Type	Louvered	Louvered	Louvered	Louvered
MicroChannel Depth in. [mm]	MicroChannel	MicroChannel	MicroChannel	MicroChannel
Face Area sq. ft. [sq. m]	0.71 [18]	0.71 [18]	0.71 [18]	0.71 [18]
Rows / FPI [FPcm]	7.1 [0.66]	7.1 [0.66]	7.1 [0.66]	7.1 [0.66]
	1 / 23 [9]	1 / 23 [9]	1 / 23 [9]	1 / 23 [9]
Indoor Coil—Fin Type				
Tube Type	Louvered	Louvered	Louvered	Louvered
MicroChannel Depth in. [mm]	MicroChannel	MicroChannel	MicroChannel	MicroChannel
Face Area sq. ft. [sq. m]	1 [25.4]	1 [25.4]	1 [25.4]	1 [25.4]
Rows / FPI [FPcm]	3.6 [0.33]	3.6 [0.33]	3.6 [0.33]	3.6 [0.33]
	1 / 17 [7]	1 / 17 [7]	1 / 17 [7]	1 / 17 [7]
Refrigerant Control	TX Valves	TX Valves	TX Valves	TX Valves
Drain Connection No./Size in. [mm]	1/0.75 [19.05]	1/0.75 [19.05]	1/0.75 [19.05]	1/0.75 [19.05]
Outdoor Fan—Type				
No. Used/Diameter in. [mm]	Propeller	Propeller	Propeller	Propeller
Drive Type/No. Speeds	1/22 [558.8]	1/22 [558.8]	1/22 [558.8]	1/22 [558.8]
CFM [L/s]	Direct/1	Direct/1	Direct/1	Direct/1
No. Motors/HP	2500 [1180]	2500 [1180]	2500 [1180]	2500 [1180]
Motor RPM	1 at 1/3 HP	1 at 1/3 HP	1 at 1/3 HP	1 at 1/3 HP
	1075	1075	1075	1075
Indoor Fan—Type				
No. Used/Diameter in. [mm]	FC Centrifugal	FC Centrifugal	FC Centrifugal	FC Centrifugal
Drive Type	1/9x7 [229x178]	1/9x7 [229x178]	1/9x7 [229x178]	1/9x7 [229x178]
No. Speeds	Direct	Direct	Direct	Direct
No. Motors	Multiple	Multiple	Multiple	Multiple
Motor HP	1	1	1	1
Motor RPM	1/4	1/4	1/4	1/4
Motor Frame Size	1075	1075	1075	1075
	48	48	48	48
Filter—Type				
Furnished	Field Supplied	Field Supplied	Field Supplied	Field Supplied
(NO.) Size Recommended in. [mm x mm x mm]	No	No	No	No
	(1)1x20x20 [25x508x508]	(1)1x20x20 [25x508x508]	(1)1x20x20 [25x508x508]	(1)1x20x20 [25x508x508]
Refrigerant Charge Oz. [g]				
	42.7 [1211]	42.7 [1211]	42.7 [1211]	42.7 [1211]
Weights				
Net Weight lbs. [kg]	398 [181]	398 [181]	403 [183]	403 [183]
Ship Weight lbs. [kg]	408 [185]	408 [185]	413 [187]	413 [187]

See Page 50 for Notes.

[] Designates Metric Conversions

NOMINAL SIZES 2-5 TONS [7.0-17.6 kW]

Model RGEA14 Series	024AJT061AB	024AJT06XAB	024AJT081AB	024AJT08XAB
Cooling Performance¹				CONTINUED →
EER/SEER ²	11/14	11/14	11/14	11/14
Nominal CFM/AHRI Rated CFM [L/s]	800/900 [378/425]	800/900 [378/425]	800/900 [378/425]	800/900 [378/425]
AHRI Net Cooling Capacity Btu [kW]	23,600 [6.91]	23,600 [6.91]	23,600 [6.91]	23,600 [6.91]
Net Sensible Capacity Btu [kW]	17,790 [5.21]	17,790 [5.21]	17,790 [5.21]	17,790 [5.21]
Net Latent Capacity Btu [kW]	5,810 [1.70]	5,810 [1.70]	5,810 [1.70]	5,810 [1.70]
Net System Power kW	2.03	2.03	2.03	2.03
Heating Performance (Gas)³				
Heating Input Btu [kW]	60,000 [17.58]	60,000 [17.58]	80,000 [23.44]	80,000 [23.44]
Heating Output Btu [kW]	48,000 [14.06]	48,000 [14.06]	65,000 [19.04]	65,000 [19.04]
Temperature Rise Range °F [°C]	40-70 [22.2-38.9]	40-70 [22.2-38.9]	35-65 [19.4-36.1]	35-65 [19.4-36.1]
AFUE % ⁴	81	81	81	81
Steady State Efficiency (%)	82	82	82	82
No. Burners	2	2	2	2
No. Stages	1	1	1	1
Gas Connection Pipe Size in. [mm]	0.5 [12.7]	0.5 [12.7]	0.5 [12.7]	0.5 [12.7]
Compressor				
No./Type	1/Scroll	1/Scroll	1/Scroll	1/Scroll
Outdoor Sound Rating (dB)⁵	76	76	76	76
Outdoor Coil—Fin Type	Louvered	Louvered	Louvered	Louvered
Tube Type	MicroChannel	MicroChannel	MicroChannel	MicroChannel
MicroChannel Depth in. [mm]	0.71 [18]	0.71 [18]	0.71 [18]	0.71 [18]
Face Area sq. ft. [sq. m]	7.1 [0.66]	7.1 [0.66]	7.1 [0.66]	7.1 [0.66]
Rows / FPI [FPcm]	1 / 23 [9]	1 / 23 [9]	1 / 23 [9]	1 / 23 [9]
Indoor Coil—Fin Type	Louvered	Louvered	Louvered	Louvered
Tube Type	MicroChannel	MicroChannel	MicroChannel	MicroChannel
MicroChannel Depth in. [mm]	1 [25.4]	1 [25.4]	1 [25.4]	1 [25.4]
Face Area sq. ft. [sq. m]	3.6 [0.33]	3.6 [0.33]	3.6 [0.33]	3.6 [0.33]
Rows / FPI [FPcm]	1 / 17 [7]	1 / 17 [7]	1 / 17 [7]	1 / 17 [7]
Refrigerant Control	TX Valves	TX Valves	TX Valves	TX Valves
Drain Connection No./Size in. [mm]	1/0.75 [19.05]	1/0.75 [19.05]	1/0.75 [19.05]	1/0.75 [19.05]
Outdoor Fan—Type	Propeller	Propeller	Propeller	Propeller
No. Used/Diameter in. [mm]	1/22 [558.8]	1/22 [558.8]	1/22 [558.8]	1/22 [558.8]
Drive Type/No. Speeds	Direct/1	Direct/1	Direct/1	Direct/1
CFM [L/s]	2500 [1180]	2500 [1180]	2500 [1180]	2500 [1180]
No. Motors/HP	1 at 1/3 HP	1 at 1/3 HP	1 at 1/3 HP	1 at 1/3 HP
Motor RPM	1075	1075	1075	1075
Indoor Fan—Type	FC Centrifugal	FC Centrifugal	FC Centrifugal	FC Centrifugal
No. Used/Diameter in. [mm]	1/10x9 [254x229]	1/10x9 [254x229]	1/10x9 [254x229]	1/10x9 [254x229]
Drive Type	Direct	Direct	Direct	Direct
No. Speeds	Multiple	Multiple	Multiple	Multiple
No. Motors	1	1	1	1
Motor HP	1/3	1/3	1/3	1/3
Motor RPM	1075	1075	1075	1075
Motor Frame Size	48	48	48	48
Filter—Type	Field Supplied	Field Supplied	Field Supplied	Field Supplied
Furnished	No	No	No	No
(NO.) Size Recommended in. [mm x mm x mm]	(1)1x20x20 [25x508x508]	(1)1x20x20 [25x508x508]	(1)1x20x20 [25x508x508]	(1)1x20x20 [25x508x508]
Refrigerant Charge Oz. [g]	42.6 [1208]	42.6 [1208]	42.6 [1208]	42.6 [1208]
Weights				
Net Weight lbs. [kg]	403 [183]	403 [183]	408 [185]	408 [185]
Ship Weight lbs. [kg]	413 [187]	413 [187]	418 [190]	418 [190]

See Page 50 for Notes.

[] Designates Metric Conversions

NOMINAL SIZES 2-5 TONS [7.0-17.6 kW]

Model RGEA14 Series	030AJD061AA	030AJD06XAA	030AJD081AA	030AJD08XAA
Cooling Performance¹				CONTINUED →
EER/SEER ²	11/14	11/14	11/14	11/14
Nominal CFM/AHRI Rated CFM [L/s]	1000/975 [472/460]	1000/975 [472/460]	1000/975 [472/460]	1000/975 [472/460]
AHRI Net Cooling Capacity Btu [kW]	28,000 [8.21]	28,000 [8.21]	28,000 [8.21]	28,000 [8.21]
Net Sensible Capacity Btu [kW]	20,750 [6.08]	20,750 [6.08]	20,750 [6.08]	20,750 [6.08]
Net Latent Capacity Btu [kW]	7,250 [2.12]	7,250 [2.12]	7,250 [2.12]	7,250 [2.12]
Net System Power kW	2.37	2.37	2.37	2.37
Heating Performance (Gas)³				
Heating Input Btu [kW]	60,000 [17.58]	60,000 [17.58]	80,000 [23.44]	80,000 [23.44]
Heating Output Btu [kW]	48,000 [14.06]	48,000 [14.06]	65,000 [19.04]	65,000 [19.04]
Temperature Rise Range °F [°C]	35-65 [19.4-36.1]	35-65 [19.4-36.1]	35-65 [19.4-36.1]	35-65 [19.4-36.1]
AFUE % ⁴	81	81	81	81
Steady State Efficiency (%)	82	82	82	82
No. Burners	3	3	3	3
No. Stages	1	1	1	1
Gas Connection Pipe Size in. [mm]	0.5 [12.7]	0.5 [12.7]	0.5 [12.7]	0.5 [12.7]
Compressor				
No./Type	1/Scroll	1/Scroll	1/Scroll	1/Scroll
Outdoor Sound Rating (dB)⁵				
	76	76	76	76
Outdoor Coil—Fin Type				
Tube Type	Louvered	Louvered	Louvered	Louvered
MicroChannel Depth in. [mm]	MicroChannel	MicroChannel	MicroChannel	MicroChannel
Face Area sq. ft. [sq. m]	0.71 [18]	0.71 [18]	0.71 [18]	0.71 [18]
Rows / FPI [FPcm]	9.9 [0.92]	9.9 [0.92]	9.9 [0.92]	9.9 [0.92]
	1 / 23 [9]	1 / 23 [9]	1 / 23 [9]	1 / 23 [9]
Indoor Coil—Fin Type				
Tube Type	Louvered	Louvered	Louvered	Louvered
MicroChannel Depth in. [mm]	MicroChannel	MicroChannel	MicroChannel	MicroChannel
Face Area sq. ft. [sq. m]	1 [25.4]	1 [25.4]	1 [25.4]	1 [25.4]
Rows / FPI [FPcm]	3.6 [0.33]	3.6 [0.33]	3.6 [0.33]	3.6 [0.33]
	1 / 23 [9]	1 / 23 [9]	1 / 23 [9]	1 / 23 [9]
Refrigerant Control	TX Valves	TX Valves	TX Valves	TX Valves
Drain Connection No./Size in. [mm]	1/0.75 [19.05]	1/0.75 [19.05]	1/0.75 [19.05]	1/0.75 [19.05]
Outdoor Fan—Type				
No. Used/Diameter in. [mm]	Propeller	Propeller	Propeller	Propeller
Drive Type/No. Speeds	1/22 [558.8]	1/22 [558.8]	1/22 [558.8]	1/22 [558.8]
CFM [L/s]	Direct/1	Direct/1	Direct/1	Direct/1
No. Motors/HP	2500 [1180]	2500 [1180]	2500 [1180]	2500 [1180]
Motor RPM	1 at 1/3 HP	1 at 1/3 HP	1 at 1/3 HP	1 at 1/3 HP
	1075	1075	1075	1075
Indoor Fan—Type				
No. Used/Diameter in. [mm]	FC Centrifugal	FC Centrifugal	FC Centrifugal	FC Centrifugal
Drive Type	1/10x9 [254x229]	1/10x9 [254x229]	1/10x9 [254x229]	1/10x9 [254x229]
No. Speeds	Direct	Direct	Direct	Direct
No. Motors	Multiple	Multiple	Multiple	Multiple
Motor HP	1	1	1	1
Motor RPM	1/2	1/2	1/2	1/2
Motor Frame Size	1075	1075	1075	1075
	48	48	48	48
Filter—Type				
Furnished	Field Supplied	Field Supplied	Field Supplied	Field Supplied
(NO.) Size Recommended in. [mm x mm x mm]	No	No	No	No
	(1)1x24x24 [25x610x610]	(1)1x24x24 [25x610x610]	(1)1x24x24 [25x610x610]	(1)1x24x24 [25x610x610]
Refrigerant Charge Oz. [g]				
	46.8 [1327]	46.8 [1327]	46.8 [1327]	46.8 [1327]
Weights				
Net Weight lbs. [kg]	403 [183]	403 [183]	408 [185]	408 [185]
Ship Weight lbs. [kg]	413 [187]	413 [187]	418 [190]	418 [190]

See Page 50 for Notes.

[] Designates Metric Conversions

NOMINAL SIZES 2-5 TONS [7.0-17.6 kW]

Model RGEA14 Series	030AJT061AB	030AJT06XAB	030AJT081AB	030AJT08XAB
Cooling Performance¹				CONTINUED →
EER/SEER ²	11/14	11/14	11/14	11/14
Nominal CFM/AHRI Rated CFM [L/s]	1000/975 [472/460]	1000/975 [472/460]	1000/975 [472/460]	1000/975 [472/460]
AHRI Net Cooling Capacity Btu [kW]	28,000 [8.21]	28,000 [8.21]	28,000 [8.21]	28,000 [8.21]
Net Sensible Capacity Btu [kW]	20,750 [6.08]	20,750 [6.08]	20,750 [6.08]	20,750 [6.08]
Net Latent Capacity Btu [kW]	7,250 [2.12]	7,250 [2.12]	7,250 [2.12]	7,250 [2.12]
Net System Power kW	2.21	2.21	2.21	2.21
Heating Performance (Gas)³				
Heating Input Btu [kW]	60,000 [17.58]	60,000 [17.58]	80,000 [23.44]	80,000 [23.44]
Heating Output Btu [kW]	48,000 [14.06]	48,000 [14.06]	65,000 [19.04]	65,000 [19.04]
Temperature Rise Range °F [°C]	40-70 [22.2-38.9]	40-70 [22.2-38.9]	35-65 [19.4-36.1]	35-65 [19.4-36.1]
AFUE % ⁴	81	81	81	81
Steady State Efficiency (%)	82	82	82	82
No. Burners	3	3	3	3
No. Stages	1	1	1	1
Gas Connection Pipe Size in. [mm]	0.5 [12.7]	0.5 [12.7]	0.5 [12.7]	0.5 [12.7]
Compressor				
No./Type	1/Scroll	1/Scroll	1/Scroll	1/Scroll
Outdoor Sound Rating (dB)⁵	76	76	76	76
Outdoor Coil—Fin Type	Louvered	Louvered	Louvered	Louvered
Tube Type	MicroChannel	MicroChannel	MicroChannel	MicroChannel
MicroChannel Depth in. [mm]	0.71 [18]	0.71 [18]	0.71 [18]	0.71 [18]
Face Area sq. ft. [sq. m]	9.9 [0.92]	9.9 [0.92]	9.9 [0.92]	9.9 [0.92]
Rows / FPI [FPcm]	1 / 23 [9]	1 / 23 [9]	1 / 23 [9]	1 / 23 [9]
Indoor Coil—Fin Type	Louvered	Louvered	Louvered	Louvered
Tube Type	MicroChannel	MicroChannel	MicroChannel	MicroChannel
MicroChannel Depth in. [mm]	1 [25.4]	1 [25.4]	1 [25.4]	1 [25.4]
Face Area sq. ft. [sq. m]	3.6 [0.33]	3.6 [0.33]	3.6 [0.33]	3.6 [0.33]
Rows / FPI [FPcm]	1 / 17 [7]	1 / 17 [7]	1 / 17 [7]	1 / 17 [7]
Refrigerant Control	TX Valves	TX Valves	TX Valves	TX Valves
Drain Connection No./Size in. [mm]	1/0.75 [19.05]	1/0.75 [19.05]	1/0.75 [19.05]	1/0.75 [19.05]
Outdoor Fan—Type	Propeller	Propeller	Propeller	Propeller
No. Used/Diameter in. [mm]	1/22 [558.8]	1/22 [558.8]	1/22 [558.8]	1/22 [558.8]
Drive Type/No. Speeds	Direct/1	Direct/1	Direct/1	Direct/1
CFM [L/s]	2500 [1180]	2500 [1180]	2500 [1180]	2500 [1180]
No. Motors/HP	1 at 1/3 HP	1 at 1/3 HP	1 at 1/3 HP	1 at 1/3 HP
Motor RPM	1075	1075	1075	1075
Indoor Fan—Type	FC Centrifugal	FC Centrifugal	FC Centrifugal	FC Centrifugal
No. Used/Diameter in. [mm]	1/10x9 [254x229]	1/10x9 [254x229]	1/10x9 [254x229]	1/10x9 [254x229]
Drive Type	Direct	Direct	Direct	Direct
No. Speeds	Multiple	Multiple	Multiple	Multiple
No. Motors	1	1	1	1
Motor HP	1/2	1/2	1/2	1/2
Motor RPM	1075	1075	1075	1075
Motor Frame Size	48	48	48	48
Filter—Type	Field Supplied	Field Supplied	Field Supplied	Field Supplied
Furnished	No	No	No	No
(NO.) Size Recommended in. [mm x mm x mm]	(1)1x24x24 [25x610x610]	(1)1x24x24 [25x610x610]	(1)1x24x24 [25x610x610]	(1)1x24x24 [25x610x610]
Refrigerant Charge Oz. [g]	46.8 [1327]	46.8 [1327]	46.8 [1327]	46.8 [1327]
Weights				
Net Weight lbs. [kg]	403 [183]	403 [183]	408 [185]	408 [185]
Ship Weight lbs. [kg]	413 [187]	413 [187]	418 [190]	418 [190]

See Page 50 for Notes.

[] Designates Metric Conversions

NOMINAL SIZES 2-5 TONS [7.0-17.6 kW]

Model RGEA14 Series	036ACD061AA	036ACD06XAA	036ACD081AA	036ACD08XAA
Cooling Performance¹				CONTINUED →
EER/SEER ²	11/14	11/14	11/14	11/14
Nominal CFM/AHRI Rated CFM [L/s]	1200/1200 [566/566]	1200/1200 [566/566]	1200/1200 [566/566]	1200/1200 [566/566]
AHRI Net Cooling Capacity Btu [kW]	33,600 [9.85]	33,600 [9.85]	33,600 [9.85]	33,600 [9.85]
Net Sensible Capacity Btu [kW]	24,380 [7.15]	24,380 [7.15]	24,380 [7.15]	24,380 [7.15]
Net Latent Capacity Btu [kW]	9,220 [2.70]	9,220 [2.70]	9,220 [2.70]	9,220 [2.70]
Net System Power kW	2.93	2.93	2.93	2.93
Heating Performance (Gas)³				
Heating Input Btu [kW]	60,000 [17.58]	60,000 [17.58]	80,000 [23.44]	80,000 [23.44]
Heating Output Btu [kW]	48,000 [14.06]	48,000 [14.06]	65,000 [19.04]	65,000 [19.04]
Temperature Rise Range °F [°C]	30-60 [16.7-33.3]	30-60 [16.7-33.3]	30-60 [16.7-33.3]	30-60 [16.7-33.3]
AFUE % ⁴	81	81	81	81
Steady State Efficiency (%)	82	82	82	82
No. Burners	3	3	3	3
No. Stages	1	1	1	1
Gas Connection Pipe Size in. [mm]	0.5 [12.7]	0.5 [12.7]	0.5 [12.7]	0.5 [12.7]
Compressor				
No./Type	1/Scroll	1/Scroll	1/Scroll	1/Scroll
Outdoor Sound Rating (dB)⁵				
	76	76	76	76
Outdoor Coil—Fin Type				
Tube Type	Louvered	Louvered	Louvered	Louvered
MicroChannel Depth in. [mm]	MicroChannel	MicroChannel	MicroChannel	MicroChannel
Face Area sq. ft. [sq. m]	0.71 [18]	0.71 [18]	0.71 [18]	0.71 [18]
Rows / FPI [FPcm]	9.8 [0.91]	9.8 [0.91]	9.8 [0.91]	9.8 [0.91]
	1 / 23 [9]	1 / 23 [9]	1 / 23 [9]	1 / 23 [9]
Indoor Coil—Fin Type				
Tube Type	Louvered	Louvered	Louvered	Louvered
MicroChannel Depth in. [mm]	MicroChannel	MicroChannel	MicroChannel	MicroChannel
Face Area sq. ft. [sq. m]	1 [25.4]	1 [25.4]	1 [25.4]	1 [25.4]
Rows / FPI [FPcm]	3.6 [0.33]	3.6 [0.33]	3.6 [0.33]	3.6 [0.33]
	1 / 23 [9]	1 / 23 [9]	1 / 23 [9]	1 / 23 [9]
Refrigerant Control	TX Valves	TX Valves	TX Valves	TX Valves
Drain Connection No./Size in. [mm]	1/0.75 [19.05]	1/0.75 [19.05]	1/0.75 [19.05]	1/0.75 [19.05]
Outdoor Fan—Type				
No. Used/Diameter in. [mm]	Propeller	Propeller	Propeller	Propeller
Drive Type/No. Speeds	1/22 [558.8]	1/22 [558.8]	1/22 [558.8]	1/22 [558.8]
CFM [L/s]	Direct/1	Direct/1	Direct/1	Direct/1
No. Motors/HP	2700 [1274]	2700 [1274]	2700 [1274]	2700 [1274]
Motor RPM	1 at 1/3 HP	1 at 1/3 HP	1 at 1/3 HP	1 at 1/3 HP
	840	840	840	840
Indoor Fan—Type				
No. Used/Diameter in. [mm]	FC Centrifugal	FC Centrifugal	FC Centrifugal	FC Centrifugal
Drive Type	1/12x9 [305x229]	1/12x9 [305x229]	1/12x9 [305x229]	1/12x9 [305x229]
No. Speeds	Direct	Direct	Direct	Direct
No. Motors	Multiple	Multiple	Multiple	Multiple
Motor HP	1	1	1	1
Motor RPM	1/2	1/2	1/2	1/2
Motor Frame Size	1075	1075	1075	1075
	48	48	48	48
Filter—Type				
Furnished	Field Supplied	Field Supplied	Field Supplied	Field Supplied
(NO.) Size Recommended in. [mm x mm x mm]	No	No	No	No
	(1)1x24x24 [25x610x610]	(1)1x24x24 [25x610x610]	(1)1x24x24 [25x610x610]	(1)1x24x24 [25x610x610]
Refrigerant Charge Oz. [g]				
	52.7 [1494]	52.7 [1494]	52.7 [1494]	52.7 [1494]
Weights				
Net Weight lbs. [kg]	411 [186]	411 [186]	416 [189]	416 [189]
Ship Weight lbs. [kg]	421 [191]	421 [191]	426 [193]	426 [193]

See Page 50 for Notes.

[] Designates Metric Conversions

NOMINAL SIZES 2-5 TONS [7.0-17.6 kW]

Model RGEA14 Series	036ACD101AA	036ACD10XAA	036ADD061AA	036ADD06XAA
Cooling Performance¹				CONTINUED →
EER/SEER ²	11/14	11/14	11/14	11/14
Nominal CFM/AHRI Rated CFM [L/s]	1200/1200 [566/566]	1200/1200 [566/566]	1200/1200 [566/566]	1200/1200 [566/566]
AHRI Net Cooling Capacity Btu [kW]	33,600 [9.85]	33,600 [9.85]	33,600 [9.85]	33,600 [9.85]
Net Sensible Capacity Btu [kW]	24,380 [7.15]	24,380 [7.15]	24,380 [7.15]	24,380 [7.15]
Net Latent Capacity Btu [kW]	9,220 [2.70]	9,220 [2.70]	9,220 [2.70]	9,220 [2.70]
Net System Power kW	2.93	2.93	2.93	2.93
Heating Performance (Gas)³				
Heating Input Btu [kW]	100,000 [29.3]	100,000 [29.3]	60,000 [17.58]	60,000 [17.58]
Heating Output Btu [kW]	81,000 [23.73]	81,000 [23.73]	48,000 [14.06]	48,000 [14.06]
Temperature Rise Range °F [°C]	40-70 [22.2-38.9]	40-70 [22.2-38.9]	30-60 [16.7-33.3]	30-60 [16.7-33.3]
AFUE % ⁴	81	81	81	81
Steady State Efficiency (%)	82	82	82	82
No. Burners	3	3	3	3
No. Stages	1	1	1	1
Gas Connection Pipe Size in. [mm]	0.5 [12.7]	0.5 [12.7]	0.5 [12.7]	0.5 [12.7]
Compressor				
No./Type	1/Scroll	1/Scroll	1/Scroll	1/Scroll
Outdoor Sound Rating (dB)⁵	76	76	76	76
Outdoor Coil—Fin Type	Louvered	Louvered	Louvered	Louvered
Tube Type	MicroChannel	MicroChannel	MicroChannel	MicroChannel
MicroChannel Depth in. [mm]	0.71 [18]	0.71 [18]	0.71 [18]	0.71 [18]
Face Area sq. ft. [sq. m]	9.8 [0.91]	9.8 [0.91]	9.8 [0.91]	9.8 [0.91]
Rows / FPI [FPcm]	1 / 23 [9]	1 / 23 [9]	1 / 23 [9]	1 / 23 [9]
Indoor Coil—Fin Type	Louvered	Louvered	Louvered	Louvered
Tube Type	MicroChannel	MicroChannel	MicroChannel	MicroChannel
MicroChannel Depth in. [mm]	1 [25.4]	1 [25.4]	1 [25.4]	1 [25.4]
Face Area sq. ft. [sq. m]	3.6 [0.33]	3.6 [0.33]	3.6 [0.33]	3.6 [0.33]
Rows / FPI [FPcm]	1 / 23 [9]	1 / 23 [9]	1 / 17 [7]	1 / 17 [7]
Refrigerant Control	TX Valves	TX Valves	TX Valves	TX Valves
Drain Connection No./Size in. [mm]	1/0.75 [19.05]	1/0.75 [19.05]	1/0.75 [19.05]	1/0.75 [19.05]
Outdoor Fan—Type	Propeller	Propeller	Propeller	Propeller
No. Used/Diameter in. [mm]	1/22 [558.8]	1/22 [558.8]	1/22 [558.8]	1/22 [558.8]
Drive Type/No. Speeds	Direct/1	Direct/1	Direct/1	Direct/1
CFM [L/s]	2700 [1274]	2700 [1274]	2700 [1274]	2700 [1274]
No. Motors/HP	1 at 1/3 HP	1 at 1/3 HP	1 at 1/3 HP	1 at 1/3 HP
Motor RPM	840	840	840	840
Indoor Fan—Type	FC Centrifugal	FC Centrifugal	FC Centrifugal	FC Centrifugal
No. Used/Diameter in. [mm]	1/12x9 [305x229]	1/12x9 [305x229]	1/12x9 [305x229]	1/12x9 [305x229]
Drive Type	Direct	Direct	Direct	Direct
No. Speeds	Multiple	Multiple	Multiple	Multiple
No. Motors	1	1	1	1
Motor HP	1/2	1/2	1/2	1/2
Motor RPM	1075	1075	1075	1075
Motor Frame Size	48	48	48	48
Filter—Type	Field Supplied	Field Supplied	Field Supplied	Field Supplied
Furnished	No	No	No	No
(NO.) Size Recommended in. [mm x mm x mm]	(1)1x24x24 [25x610x610]	(1)1x24x24 [25x610x610]	(1)1x24x24 [25x610x610]	(1)1x24x24 [25x610x610]
Refrigerant Charge Oz. [g]	52.7 [1494]	52.7 [1494]	52.7 [1494]	52.7 [1494]
Weights				
Net Weight lbs. [kg]	421 [191]	421 [191]	411 [186]	411 [186]
Ship Weight lbs. [kg]	431 [196]	431 [196]	421 [191]	421 [191]

See Page 50 for Notes.

[] Designates Metric Conversions

NOMINAL SIZES 2-5 TONS [7.0-17.6 kW]

Model RGEA14 Series	036ADD081AA	036ADD08XAA	036ADD101AA	036ADD10XAA
Cooling Performance¹				CONTINUED →
EER/SEER ²	11/14	11/14	11/14	11/14
Nominal CFM/AHRI Rated CFM [L/s]	1200/1200 [566/566]	1200/1200 [566/566]	1200/1200 [566/566]	1200/1200 [566/566]
AHRI Net Cooling Capacity Btu [kW]	33,600 [9.85]	33,600 [9.85]	33,600 [9.85]	33,600 [9.85]
Net Sensible Capacity Btu [kW]	24,380 [7.15]	24,380 [7.15]	24,380 [7.15]	24,380 [7.15]
Net Latent Capacity Btu [kW]	9,220 [2.70]	9,220 [2.70]	9,220 [2.70]	9,220 [2.70]
Net System Power kW	2.93	2.93	2.93	2.93
Heating Performance (Gas)³				
Heating Input Btu [kW]	80,000 [23.44]	80,000 [23.44]	100,000 [29.3]	100,000 [29.3]
Heating Output Btu [kW]	65,000 [19.04]	65,000 [19.04]	81,000 [23.73]	81,000 [23.73]
Temperature Rise Range °F [°C]	30-60 [16.7-33.3]	30-60 [16.7-33.3]	40-70 [22.2-38.9]	40-70 [22.2-38.9]
AFUE % ⁴	81	81	81	81
Steady State Efficiency (%)	82	82	82	82
No. Burners	3	3	3	3
No. Stages	1	1	1	1
Gas Connection Pipe Size in. [mm]	0.5 [12.7]	0.5 [12.7]	0.5 [12.7]	0.5 [12.7]
Compressor				
No./Type	1/Scroll	1/Scroll	1/Scroll	1/Scroll
Outdoor Sound Rating (dB)⁵				
	76	76	76	76
Outdoor Coil—Fin Type				
Tube Type	Louvered	Louvered	Louvered	Louvered
MicroChannel Depth in. [mm]	MicroChannel	MicroChannel	MicroChannel	MicroChannel
Face Area sq. ft. [sq. m]	0.71 [18]	0.71 [18]	0.71 [18]	0.71 [18]
Rows / FPI [FPcm]	9.8 [0.91]	9.8 [0.91]	9.8 [0.91]	9.8 [0.91]
	1 / 23 [9]	1 / 23 [9]	1 / 23 [9]	1 / 23 [9]
Indoor Coil—Fin Type				
Tube Type	Louvered	Louvered	Louvered	Louvered
MicroChannel Depth in. [mm]	MicroChannel	MicroChannel	MicroChannel	MicroChannel
Face Area sq. ft. [sq. m]	1 [25.4]	1 [25.4]	1 [25.4]	1 [25.4]
Rows / FPI [FPcm]	3.6 [0.33]	3.6 [0.33]	3.6 [0.33]	3.6 [0.33]
	1 / 17 [7]	1 / 17 [7]	1 / 17 [7]	1 / 17 [7]
Refrigerant Control	TX Valves	TX Valves	TX Valves	TX Valves
Drain Connection No./Size in. [mm]	1/0.75 [19.05]	1/0.75 [19.05]	1/0.75 [19.05]	1/0.75 [19.05]
Outdoor Fan—Type				
No. Used/Diameter in. [mm]	Propeller	Propeller	Propeller	Propeller
Drive Type/No. Speeds	1/22 [558.8]	1/22 [558.8]	1/22 [558.8]	1/22 [558.8]
CFM [L/s]	Direct/1	Direct/1	Direct/1	Direct/1
No. Motors/HP	2700 [1274]	2700 [1274]	2700 [1274]	2700 [1274]
Motor RPM	1 at 1/3 HP	1 at 1/3 HP	1 at 1/3 HP	1 at 1/3 HP
	840	840	840	840
Indoor Fan—Type				
No. Used/Diameter in. [mm]	FC Centrifugal	FC Centrifugal	FC Centrifugal	FC Centrifugal
Drive Type	1/12x9 [305x229]	1/12x9 [305x229]	1/12x9 [305x229]	1/12x9 [305x229]
No. Speeds	Direct	Direct	Direct	Direct
No. Motors	Multiple	Multiple	Multiple	Multiple
Motor HP	1	1	1	1
Motor RPM	1/2	1/2	1/2	1/2
Motor Frame Size	1075	1075	1075	1075
	48	48	48	48
Filter—Type				
Furnished	Field Supplied	Field Supplied	Field Supplied	Field Supplied
(NO.) Size Recommended in. [mm x mm x mm]	No	No	No	No
	(1)1x24x24 [25x610x610]	(1)1x24x24 [25x610x610]	(1)1x24x24 [25x610x610]	(1)1x24x24 [25x610x610]
Refrigerant Charge Oz. [g]				
	52.7 [1494]	52.7 [1494]	52.7 [1494]	52.7 [1494]
Weights				
Net Weight lbs. [kg]	416 [189]	416 [189]	421 [191]	421 [191]
Ship Weight lbs. [kg]	426 [193]	426 [193]	431 [196]	431 [196]

See Page 50 for Notes.

[] Designates Metric Conversions

NOMINAL SIZES 2-5 TONS [7.0-17.6 kW]

Model RGEA14 Series	036AJD061AA	036AJD06XAA	036AJD081AA	036AJD08XAA
Cooling Performance¹				CONTINUED →
EER/SEER ²	11/14	11/14	11/14	11/14
Nominal CFM/AHRI Rated CFM [L/s]	1200/1200 [566/566]	1200/1200 [566/566]	1200/1200 [566/566]	1200/1200 [566/566]
AHRI Net Cooling Capacity Btu [kW]	33,600 [9.85]	33,600 [9.85]	33,600 [9.85]	33,600 [9.85]
Net Sensible Capacity Btu [kW]	24,380 [7.15]	24,380 [7.15]	24,380 [7.15]	24,380 [7.15]
Net Latent Capacity Btu [kW]	9,220 [2.70]	9,220 [2.70]	9,220 [2.70]	9,220 [2.70]
Net System Power kW	2.93	2.93	2.93	2.93
Heating Performance (Gas)³				
Heating Input Btu [kW]	60,000 [17.58]	60,000 [17.58]	80,000 [23.44]	80,000 [23.44]
Heating Output Btu [kW]	48,000 [14.06]	48,000 [14.06]	65,000 [19.04]	65,000 [19.04]
Temperature Rise Range °F [°C]	30-60 [16.7-33.3]	30-60 [16.7-33.3]	30-60 [16.7-33.3]	30-60 [16.7-33.3]
AFUE % ⁴	81	81	81	81
Steady State Efficiency (%)	82	82	82	82
No. Burners	3	3	3	3
No. Stages	1	1	1	1
Gas Connection Pipe Size in. [mm]	0.5 [12.7]	0.5 [12.7]	0.5 [12.7]	0.5 [12.7]
Compressor				
No./Type	1/Scroll	1/Scroll	1/Scroll	1/Scroll
Outdoor Sound Rating (dB)⁵				
	76	76	76	76
Outdoor Coil—Fin Type				
Tube Type	Louvered	Louvered	Louvered	Louvered
MicroChannel Depth in. [mm]	MicroChannel	MicroChannel	MicroChannel	MicroChannel
Face Area sq. ft. [sq. m]	0.71 [18]	0.71 [18]	0.71 [18]	0.71 [18]
Rows / FPI [FPcm]	9.8 [0.91]	9.8 [0.91]	9.8 [0.91]	9.8 [0.91]
	1 / 23 [9]	1 / 23 [9]	1 / 23 [9]	1 / 23 [9]
Indoor Coil—Fin Type				
Tube Type	Louvered	Louvered	Louvered	Louvered
MicroChannel Depth in. [mm]	MicroChannel	MicroChannel	MicroChannel	MicroChannel
Face Area sq. ft. [sq. m]	1 [25.4]	1 [25.4]	1 [25.4]	1 [25.4]
Rows / FPI [FPcm]	3.6 [0.33]	3.6 [0.33]	3.6 [0.33]	3.6 [0.33]
	1 / 17 [7]	1 / 17 [7]	1 / 17 [7]	1 / 17 [7]
Refrigerant Control	TX Valves	TX Valves	TX Valves	TX Valves
Drain Connection No./Size in. [mm]	1/0.75 [19.05]	1/0.75 [19.05]	1/0.75 [19.05]	1/0.75 [19.05]
Outdoor Fan—Type				
No. Used/Diameter in. [mm]	Propeller	Propeller	Propeller	Propeller
Drive Type/No. Speeds	1/22 [558.8]	1/22 [558.8]	1/22 [558.8]	1/22 [558.8]
CFM [L/s]	Direct/1	Direct/1	Direct/1	Direct/1
No. Motors/HP	2700 [1274]	2700 [1274]	2700 [1274]	2700 [1274]
Motor RPM	1 at 1/3 HP	1 at 1/3 HP	1 at 1/3 HP	1 at 1/3 HP
	840	840	840	840
Indoor Fan—Type				
No. Used/Diameter in. [mm]	FC Centrifugal	FC Centrifugal	FC Centrifugal	FC Centrifugal
Drive Type	1/12x9 [305x229]	1/12x9 [305x229]	1/12x9 [305x229]	1/12x9 [305x229]
No. Speeds	Direct	Direct	Direct	Direct
No. Motors	Multiple	Multiple	Multiple	Multiple
Motor HP	1	1	1	1
Motor RPM	1/2	1/2	1/2	1/2
Motor Frame Size	1075	1075	1075	1075
	48	48	48	48
Filter—Type				
Furnished	Field Supplied	Field Supplied	Field Supplied	Field Supplied
(NO.) Size Recommended in. [mm x mm x mm]	No	No	No	No
	(1)1x24x24 [25x610x610]	(1)1x24x24 [25x610x610]	(1)1x24x24 [25x610x610]	(1)1x24x24 [25x610x610]
Refrigerant Charge Oz. [g]				
	52.7 [1494]	52.7 [1494]	52.7 [1494]	52.7 [1494]
Weights				
Net Weight lbs. [kg]	411 [186]	411 [186]	416 [189]	416 [189]
Ship Weight lbs. [kg]	421 [191]	421 [191]	426 [193]	426 [193]

See Page 50 for Notes.

[] Designates Metric Conversions

NOMINAL SIZES 2-5 TONS [7.0-17.6 kW]

Model RGEA14 Series	036AJD101AA	036AJD10XAA	036AJT061AB	036AJT06XAB
Cooling Performance¹				CONTINUED →
EER/SEER ²	11/14	11/14	11/14	11/14
Nominal CFM/AHRI Rated CFM [L/s]	1200/1200 [566/566]	1200/1200 [566/566]	1200/1200 [566/566]	1200/1200 [566/566]
AHRI Net Cooling Capacity Btu [kW]	33,600 [9.85]	33,600 [9.85]	33,600 [9.85]	33,600 [9.85]
Net Sensible Capacity Btu [kW]	24,380 [7.15]	24,380 [7.15]	24,380 [7.15]	24,380 [7.15]
Net Latent Capacity Btu [kW]	9,220 [2.70]	9,220 [2.70]	9,220 [2.70]	9,220 [2.70]
Net System Power kW	2.93	2.93	2.77	2.77
Heating Performance (Gas)³				
Heating Input Btu [kW]	100,000 [29.3]	100,000 [29.3]	60,000 [17.58]	60,000 [17.58]
Heating Output Btu [kW]	81,000 [23.73]	81,000 [23.73]	48,000 [14.06]	48,000 [14.06]
Temperature Rise Range °F [°C]	40-70 [22.2-38.9]	40-70 [22.2-38.9]	40-70 [22.2-38.9]	40-70 [22.2-38.9]
AFUE % ⁴	81	81	81	81
Steady State Efficiency (%)	82	82	82	82
No. Burners	3	3	3	3
No. Stages	1	1	1	1
Gas Connection Pipe Size in. [mm]	0.5 [12.7]	0.5 [12.7]	0.5 [12.7]	0.5 [12.7]
Compressor				
No./Type	1/Scroll	1/Scroll	1/Scroll	1/Scroll
Outdoor Sound Rating (dB)⁵				
	76	76	76	76
Outdoor Coil—Fin Type				
Tube Type	Louvered	Louvered	Louvered	Louvered
MicroChannel Depth in. [mm]	MicroChannel	MicroChannel	MicroChannel	MicroChannel
Face Area sq. ft. [sq. m]	0.71 [18]	0.71 [18]	0.71 [18]	0.71 [18]
Rows / FPI [FPcm]	9.8 [0.91]	9.8 [0.91]	9.8 [0.91]	9.8 [0.91]
	1 / 23 [9]	1 / 23 [9]	1 / 23 [9]	1 / 23 [9]
Indoor Coil—Fin Type				
Tube Type	Louvered	Louvered	Louvered	Louvered
MicroChannel Depth in. [mm]	MicroChannel	MicroChannel	MicroChannel	MicroChannel
Face Area sq. ft. [sq. m]	1 [25.4]	1 [25.4]	1 [25.4]	1 [25.4]
Rows / FPI [FPcm]	3.6 [0.33]	3.6 [0.33]	3.6 [0.33]	3.6 [0.33]
	1 / 17 [7]	1 / 17 [7]	1 / 17 [7]	1 / 17 [7]
Refrigerant Control	TX Valves	TX Valves	TX Valves	TX Valves
Drain Connection No./Size in. [mm]	1/0.75 [19.05]	1/0.75 [19.05]	1/0.75 [19.05]	1/0.75 [19.05]
Outdoor Fan—Type				
No. Used/Diameter in. [mm]	Propeller	Propeller	Propeller	Propeller
Drive Type/No. Speeds	1/22 [558.8]	1/22 [558.8]	1/22 [558.8]	1/22 [558.8]
CFM [L/s]	Direct/1	Direct/1	Direct/1	Direct/1
No. Motors/HP	2700 [1274]	2700 [1274]	2700 [1274]	2700 [1274]
Motor RPM	1 at 1/3 HP	1 at 1/3 HP	1 at 1/3 HP	1 at 1/3 HP
	840	840	1075	1075
Indoor Fan—Type				
No. Used/Diameter in. [mm]	FC Centrifugal	FC Centrifugal	FC Centrifugal	FC Centrifugal
Drive Type	1/12x9 [305x229]	1/12x9 [305x229]	1/12x9 [305x229]	1/12x9 [305x229]
No. Speeds	Direct	Direct	Direct	Direct
No. Motors	Multiple	Multiple	Multiple	Multiple
Motor HP	1	1	1	1
Motor RPM	1/2	1/2	1/2	1/2
Motor Frame Size	1075	1075	1075	1075
	48	48	48	48
Filter—Type				
Furnished	Field Supplied	Field Supplied	Field Supplied	Field Supplied
(NO.) Size Recommended in. [mm x mm x mm]	No	No	No	No
	(1)1x24x24 [25x610x610]	(1)1x24x24 [25x610x610]	(1)1x24x24 [25x610x610]	(1)1x24x24 [25x610x610]
Refrigerant Charge Oz. [g]				
	52.7 [1494]	52.7 [1494]	52.7 [1494]	52.7 [1494]
Weights				
Net Weight lbs. [kg]	421 [191]	421 [191]	411 [186]	411 [186]
Ship Weight lbs. [kg]	431 [196]	431 [196]	421 [191]	421 [191]

See Page 50 for Notes.

[] Designates Metric Conversions

NOMINAL SIZES 2-5 TONS [7.0-17.6 kW]

Model RGEA14 Series	036AJT081AB	036AJT08XAB	036AJT101AB	036AJT10XAB
Cooling Performance¹				CONTINUED →
EER/SEER ²	11/14	11/14	11/14	11/14
Nominal CFM/AHRI Rated CFM [L/s]	1200/1200 [566/566]	1200/1200 [566/566]	1200/1200 [566/566]	1200/1200 [566/566]
AHRI Net Cooling Capacity Btu [kW]	33,600 [9.85]	33,600 [9.85]	33,600 [9.85]	33,600 [9.85]
Net Sensible Capacity Btu [kW]	24,380 [7.15]	24,380 [7.15]	24,380 [7.15]	24,380 [7.15]
Net Latent Capacity Btu [kW]	9,220 [2.70]	9,220 [2.70]	9,220 [2.70]	9,220 [2.70]
Net System Power kW	2.77	2.77	2.77	2.77
Heating Performance (Gas)³				
Heating Input Btu [kW]	80,000 [23.44]	80,000 [23.44]	100,000 [29.3]	100,000 [29.3]
Heating Output Btu [kW]	65,000 [19.04]	65,000 [19.04]	81,000 [23.73]	81,000 [23.73]
Temperature Rise Range °F [°C]	35-65 [19.4-36.1]	35-65 [19.4-36.1]	45-75 [25-41.7]	45-75 [25-41.7]
AFUE % ⁴	81	81	81	81
Steady State Efficiency (%)	82	82	82	82
No. Burners	3	3	3	3
No. Stages	1	1	1	1
Gas Connection Pipe Size in. [mm]	0.5 [12.7]	0.5 [12.7]	0.5 [12.7]	0.5 [12.7]
Compressor				
No./Type	1/Scroll	1/Scroll	1/Scroll	1/Scroll
Outdoor Sound Rating (dB)⁵	76	76	76	76
Outdoor Coil—Fin Type	Louvered	Louvered	Louvered	Louvered
Tube Type	MicroChannel	MicroChannel	MicroChannel	MicroChannel
MicroChannel Depth in. [mm]	0.71 [18]	0.71 [18]	0.71 [18]	0.71 [18]
Face Area sq. ft. [sq. m]	9.8 [0.91]	9.8 [0.91]	9.8 [0.91]	9.8 [0.91]
Rows / FPI [FPcm]	1 / 23 [9]	1 / 23 [9]	1 / 23 [9]	1 / 23 [9]
Indoor Coil—Fin Type	Louvered	Louvered	Louvered	Louvered
Tube Type	MicroChannel	MicroChannel	MicroChannel	MicroChannel
MicroChannel Depth in. [mm]	1 [25.4]	1 [25.4]	1 [25.4]	1 [25.4]
Face Area sq. ft. [sq. m]	3.6 [0.33]	3.6 [0.33]	3.6 [0.33]	3.6 [0.33]
Rows / FPI [FPcm]	1 / 17 [7]	1 / 17 [7]	1 / 17 [7]	1 / 17 [7]
Refrigerant Control	TX Valves	TX Valves	TX Valves	TX Valves
Drain Connection No./Size in. [mm]	1/0.75 [19.05]	1/0.75 [19.05]	1/0.75 [19.05]	1/0.75 [19.05]
Outdoor Fan—Type	Propeller	Propeller	Propeller	Propeller
No. Used/Diameter in. [mm]	1/22 [558.8]	1/22 [558.8]	1/22 [558.8]	1/22 [558.8]
Drive Type/No. Speeds	Direct/1	Direct/1	Direct/1	Direct/1
CFM [L/s]	2700 [1274]	2700 [1274]	2700 [1274]	2700 [1274]
No. Motors/HP	1 at 1/3 HP	1 at 1/3 HP	1 at 1/3 HP	1 at 1/3 HP
Motor RPM	1075	1075	1075	1075
Indoor Fan—Type	FC Centrifugal	FC Centrifugal	FC Centrifugal	FC Centrifugal
No. Used/Diameter in. [mm]	1/12x9 [305x229]	1/12x9 [305x229]	1/12x9 [305x229]	1/12x9 [305x229]
Drive Type	Direct	Direct	Direct	Direct
No. Speeds	Multiple	Multiple	Multiple	Multiple
No. Motors	1	1	1	1
Motor HP	1/2	1/2	1/2	1/2
Motor RPM	1075	1075	1075	1075
Motor Frame Size	48	48	48	48
Filter—Type	Field Supplied	Field Supplied	Field Supplied	Field Supplied
Furnished	No	No	No	No
(NO.) Size Recommended in. [mm x mm x mm]	(1)1x24x24 [25x610x610]	(1)1x24x24 [25x610x610]	(1)1x24x24 [25x610x610]	(1)1x24x24 [25x610x610]
Refrigerant Charge Oz. [g]	52.7 [1494]	52.7 [1494]	52.7 [1494]	52.7 [1494]
Weights				
Net Weight lbs. [kg]	416 [189]	416 [189]	421 [191]	421 [191]
Ship Weight lbs. [kg]	426 [193]	426 [193]	431 [196]	431 [196]

See Page 50 for Notes.

[] Designates Metric Conversions

NOMINAL SIZES 2-5 TONS [7.0-17.6 kW]

Model RGEA14 Series	042ACT081AA	042ACT08XAA	042ACT101AA	042ACT10XAA
Cooling Performance¹				CONTINUED →
EER/SEER ²	11/14	11/14	11/14	11/14
Nominal CFM/AHRI Rated CFM [L/s]	1400/1300 [661/613]	1400/1300 [661/613]	1400/1300 [661/613]	1400/1300 [661/613]
AHRI Net Cooling Capacity Btu [kW]	39,000 [11.43]	39,000 [11.43]	39,000 [11.43]	39,000 [11.43]
Net Sensible Capacity Btu [kW]	28,270 [8.29]	28,270 [8.29]	28,270 [8.29]	28,270 [8.29]
Net Latent Capacity Btu [kW]	10,730 [3.14]	10,730 [3.14]	10,730 [3.14]	10,730 [3.14]
Net System Power kW	3.27	3.27	3.27	3.27
Heating Performance (Gas)³				
Heating Input Btu [kW]	80,000 [23.44]	80,000 [23.44]	100,000 [29.3]	100,000 [29.3]
Heating Output Btu [kW]	65,000 [19.04]	65,000 [19.04]	81,000 [23.73]	81,000 [23.73]
Temperature Rise Range °F [°C]	35-65 [19.4-36.1]	35-65 [19.4-36.1]	45-75 [25-41.7]	45-75 [25-41.7]
AFUE % ⁴	81	81	81	81
Steady State Efficiency (%)	82	82	82	82
No. Burners	4	4	4	4
No. Stages	1	1	1	1
Gas Connection Pipe Size in. [mm]	0.5 [12.7]	0.5 [12.7]	0.5 [12.7]	0.5 [12.7]
Compressor				
No./Type	1/Scroll	1/Scroll	1/Scroll	1/Scroll
Outdoor Sound Rating (dB)⁵				
	76	76	76	76
Outdoor Coil—Fin Type				
Tube Type	Louvered	Louvered	Louvered	Louvered
MicroChannel Depth in. [mm]	MicroChannel	MicroChannel	MicroChannel	MicroChannel
Face Area sq. ft. [sq. m]	0.71 [18]	0.71 [18]	0.71 [18]	0.71 [18]
Rows / FPI [FPcm]	14.1 [1.31]	14.1 [1.31]	14.1 [1.31]	14.1 [1.31]
	1 / 23 [9]	1 / 23 [9]	1 / 23 [9]	1 / 23 [9]
Indoor Coil—Fin Type				
Tube Type	Louvered	Louvered	Louvered	Louvered
MicroChannel Depth in. [mm]	MicroChannel	MicroChannel	MicroChannel	MicroChannel
Face Area sq. ft. [sq. m]	1 [25.4]	1 [25.4]	1 [25.4]	1 [25.4]
Rows / FPI [FPcm]	3.6 [0.33]	3.6 [0.33]	3.6 [0.33]	3.6 [0.33]
	1 / 17 [7]	1 / 17 [7]	1 / 17 [7]	1 / 17 [7]
Refrigerant Control	TX Valves	TX Valves	TX Valves	TX Valves
Drain Connection No./Size in. [mm]	1/0.75 [19.05]	1/0.75 [19.05]	1/0.75 [19.05]	1/0.75 [19.05]
Outdoor Fan—Type				
No. Used/Diameter in. [mm]	Propeller	Propeller	Propeller	Propeller
Drive Type/No. Speeds	1/22 [558.8]	1/22 [558.8]	1/22 [558.8]	1/22 [558.8]
CFM [L/s]	Direct/1	Direct/1	Direct/1	Direct/1
No. Motors/HP	3500 [1652]	3500 [1652]	3500 [1652]	3500 [1652]
Motor RPM	1 at 1/3 HP	1 at 1/3 HP	1 at 1/3 HP	1 at 1/3 HP
	1075	1075	1075	1075
Indoor Fan—Type				
No. Used/Diameter in. [mm]	FC Centrifugal	FC Centrifugal	FC Centrifugal	FC Centrifugal
Drive Type	1/12x9 [305x229]	1/12x9 [305x229]	1/12x9 [305x229]	1/12x9 [305x229]
No. Speeds	Direct	Direct	Direct	Direct
No. Motors	Multiple	Multiple	Multiple	Multiple
Motor HP	1	1	1	1
Motor RPM	3/4	3/4	3/4	3/4
Motor Frame Size	1075	1075	1075	1075
	48	48	48	48
Filter—Type				
Furnished	Field Supplied	Field Supplied	Field Supplied	Field Supplied
(NO.) Size Recommended in. [mm x mm x mm]	No	No	No	No
	(1)1x24x24 [25x610x610]	(1)1x24x24 [25x610x610]	(1)1x24x24 [25x610x610]	(1)1x24x24 [25x610x610]
Refrigerant Charge Oz. [g]				
	53.6 [1520]	53.6 [1520]	53.6 [1520]	53.6 [1520]
Weights				
Net Weight lbs. [kg]	441 [200]	441 [200]	446 [202]	446 [202]
Ship Weight lbs. [kg]	451 [205]	451 [205]	456 [207]	456 [207]

See Page 50 for Notes.

[] Designates Metric Conversions

NOMINAL SIZES 2-5 TONS [7.0-17.6 kW]

Model RGEA14 Series	042AJT081AA	042AJT081AB	042AJT08XAA	042AJT08XAB
Cooling Performance¹				CONTINUED →
EER/SEER ²	11/14	11/14	11/14	11/14
Nominal CFM/AHRI Rated CFM [L/s]	1400/1300 [661/613]	1400/1300 [661/613]	1400/1300 [661/613]	1400/1300 [661/613]
AHRI Net Cooling Capacity Btu [kW]	39,000 [11.43]	39,000 [11.43]	39,000 [11.43]	39,000 [11.43]
Net Sensible Capacity Btu [kW]	28,270 [8.29]	28,270 [8.29]	28,270 [8.29]	28,270 [8.29]
Net Latent Capacity Btu [kW]	10,730 [3.14]	10,730 [3.14]	10,730 [3.14]	10,730 [3.14]
Net System Power kW	3.27	3.27	3.27	3.27
Heating Performance (Gas)³				
Heating Input Btu [kW]	80,000 [23.44]	80,000 [23.44]	80,000 [23.44]	80,000 [23.44]
Heating Output Btu [kW]	65,000 [19.04]	65,000 [19.04]	65,000 [19.04]	65,000 [19.04]
Temperature Rise Range °F [°C]	35-65 [19.4-36.1]	35-65 [19.4-36.1]	35-65 [19.4-36.1]	35-65 [19.4-36.1]
AFUE % ⁴	81	81	81	81
Steady State Efficiency (%)	82	82	82	82
No. Burners	4	4	4	4
No. Stages	1	1	1	1
Gas Connection Pipe Size in. [mm]	0.5 [12.7]	0.5 [12.7]	0.5 [12.7]	0.5 [12.7]
Compressor				
No./Type	1/Scroll	1/Scroll	1/Scroll	1/Scroll
Outdoor Sound Rating (dB)⁵	76	76	76	76
Outdoor Coil—Fin Type	Louvered	Louvered	Louvered	Louvered
Tube Type	MicroChannel	MicroChannel	MicroChannel	MicroChannel
MicroChannel Depth in. [mm]	0.71 [18]	0.71 [18]	0.71 [18]	0.71 [18]
Face Area sq. ft. [sq. m]	14.1 [1.31]	14.1 [1.31]	14.1 [1.31]	14.1 [1.31]
Rows / FPI [FPcm]	1 / 23 [9]	1 / 23 [9]	1 / 23 [9]	1 / 23 [9]
Indoor Coil—Fin Type	Louvered	Louvered	Louvered	Louvered
Tube Type	MicroChannel	MicroChannel	MicroChannel	MicroChannel
MicroChannel Depth in. [mm]	1 [25.4]	1 [25.4]	1 [25.4]	1 [25.4]
Face Area sq. ft. [sq. m]	3.6 [0.33]	3.6 [0.33]	3.6 [0.33]	3.6 [0.33]
Rows / FPI [FPcm]	1 / 17 [7]	1 / 17 [7]	1 / 17 [7]	1 / 17 [7]
Refrigerant Control	TX Valves	TX Valves	TX Valves	TX Valves
Drain Connection No./Size in. [mm]	1/0.75 [19.05]	1/0.75 [19.05]	1/0.75 [19.05]	1/0.75 [19.05]
Outdoor Fan—Type	Propeller	Propeller	Propeller	Propeller
No. Used/Diameter in. [mm]	1/22 [558.8]	1/22 [558.8]	1/22 [558.8]	1/22 [558.8]
Drive Type/No. Speeds	Direct/1	Direct/1	Direct/1	Direct/1
CFM [L/s]	3500 [1652]	3500 [1652]	3500 [1652]	3500 [1652]
No. Motors/HP	1 at 1/3 HP	1 at 1/3 HP	1 at 1/3 HP	1 at 1/3 HP
Motor RPM	1075	1075	1075	1075
Indoor Fan—Type	FC Centrifugal	FC Centrifugal	FC Centrifugal	FC Centrifugal
No. Used/Diameter in. [mm]	1/12x9 [305x229]	1/12x9 [305x229]	1/12x9 [305x229]	1/12x9 [305x229]
Drive Type	Direct	Direct	Direct	Direct
No. Speeds	Multiple	Multiple	Multiple	Multiple
No. Motors	1	1	1	1
Motor HP	3/4	3/4	3/4	3/4
Motor RPM	1075	1075	1075	1075
Motor Frame Size	48	48	48	48
Filter—Type	Field Supplied	Field Supplied	Field Supplied	Field Supplied
Furnished	No	No	No	No
(NO.) Size Recommended in. [mm x mm x mm]	(1)1x24x24 [25x610x610]	(1)1x24x24 [25x610x610]	(1)1x24x24 [25x610x610]	(1)1x24x24 [25x610x610]
Refrigerant Charge Oz. [g]	53.6 [1520]	53.6 [1520]	53.6 [1520]	53.6 [1520]
Weights				
Net Weight lbs. [kg]	441 [200]	441 [200]	441 [200]	441 [200]
Ship Weight lbs. [kg]	451 [205]	451 [205]	451 [205]	451 [205]

See Page 50 for Notes.

[] Designates Metric Conversions

NOMINAL SIZES 2-5 TONS [7.0-17.6 kW]

Model RGEA14 Series	042AJT101AA	042AJT101AB	042AJT10XAA	042AJT10XAB
Cooling Performance¹				CONTINUED →
EER/SEER ²	11/14	11/14	11/14	11/14
Nominal CFM/AHRI Rated CFM [L/s]	1400/1300 [661/613]	1400/1300 [661/613]	1400/1300 [661/613]	1400/1300 [661/613]
AHRI Net Cooling Capacity Btu [kW]	39,000 [11.43]	39,000 [11.43]	39,000 [11.43]	39,000 [11.43]
Net Sensible Capacity Btu [kW]	28,270 [8.29]	28,270 [8.29]	28,270 [8.29]	28,270 [8.29]
Net Latent Capacity Btu [kW]	10,730 [3.14]	10,730 [3.14]	10,730 [3.14]	10,730 [3.14]
Net System Power kW	3.27	3.27	3.27	3.27
Heating Performance (Gas)³				
Heating Input Btu [kW]	100,000 [29.3]	100,000 [29.3]	100,000 [29.3]	100,000 [29.3]
Heating Output Btu [kW]	81,000 [23.73]	81,000 [23.73]	81,000 [23.73]	81,000 [23.73]
Temperature Rise Range °F [°C]	45-75 [25-41.7]	45-75 [25-41.7]	45-75 [25-41.7]	45-75 [25-41.7]
AFUE % ⁴	81	81	81	81
Steady State Efficiency (%)	82	82	82	82
No. Burners	4	4	4	4
No. Stages	1	1	1	1
Gas Connection Pipe Size in. [mm]	0.5 [12.7]	0.5 [12.7]	0.5 [12.7]	0.5 [12.7]
Compressor				
No./Type	1/Scroll	1/Scroll	1/Scroll	1/Scroll
Outdoor Sound Rating (dB)⁵				
	76	76	76	76
Outdoor Coil—Fin Type				
Tube Type	Louvered	Louvered	Louvered	Louvered
MicroChannel Depth in. [mm]	MicroChannel	MicroChannel	MicroChannel	MicroChannel
Face Area sq. ft. [sq. m]	0.71 [18]	0.71 [18]	0.71 [18]	0.71 [18]
Rows / FPI [FPcm]	14.1 [1.31]	14.1 [1.31]	14.1 [1.31]	14.1 [1.31]
	1 / 23 [9]	1 / 23 [9]	1 / 23 [9]	1 / 23 [9]
Indoor Coil—Fin Type				
Tube Type	Louvered	Louvered	Louvered	Louvered
MicroChannel Depth in. [mm]	MicroChannel	MicroChannel	MicroChannel	MicroChannel
Face Area sq. ft. [sq. m]	1 [25.4]	1 [25.4]	1 [25.4]	1 [25.4]
Rows / FPI [FPcm]	3.6 [0.33]	3.6 [0.33]	3.6 [0.33]	3.6 [0.33]
	1 / 17 [7]	1 / 17 [7]	1 / 17 [7]	1 / 17 [7]
Refrigerant Control	TX Valves	TX Valves	TX Valves	TX Valves
Drain Connection No./Size in. [mm]	1/0.75 [19.05]	1/0.75 [19.05]	1/0.75 [19.05]	1/0.75 [19.05]
Outdoor Fan—Type				
No. Used/Diameter in. [mm]	Propeller	Propeller	Propeller	Propeller
Drive Type/No. Speeds	1/22 [558.8]	1/22 [558.8]	1/22 [558.8]	1/22 [558.8]
CFM [L/s]	Direct/1	Direct/1	Direct/1	Direct/1
No. Motors/HP	3500 [1652]	3500 [1652]	3500 [1652]	3500 [1652]
Motor RPM	1 at 1/3 HP	1 at 1/3 HP	1 at 1/3 HP	1 at 1/3 HP
	1075	1075	1075	1075
Indoor Fan—Type				
No. Used/Diameter in. [mm]	FC Centrifugal	FC Centrifugal	FC Centrifugal	FC Centrifugal
Drive Type	1/12x9 [305x229]	1/12x9 [305x229]	1/12x9 [305x229]	1/12x9 [305x229]
No. Speeds	Direct	Direct	Direct	Direct
No. Motors	Multiple	Multiple	Multiple	Multiple
Motor HP	1	1	1	1
Motor RPM	3/4	3/4	3/4	3/4
Motor Frame Size	1075	1075	1075	1075
	48	48	48	48
Filter—Type				
Furnished	Field Supplied	Field Supplied	Field Supplied	Field Supplied
(NO.) Size Recommended in. [mm x mm x mm]	No	No	No	No
	(1)1x24x24 [25x610x610]	(1)1x24x24 [25x610x610]	(1)1x24x24 [25x610x610]	(1)1x24x24 [25x610x610]
Refrigerant Charge Oz. [g]				
	53.6 [1520]	53.6 [1520]	53.6 [1520]	53.6 [1520]
Weights				
Net Weight lbs. [kg]	446 [202]	446 [202]	446 [202]	446 [202]
Ship Weight lbs. [kg]	456 [207]	456 [207]	456 [207]	456 [207]

See Page 50 for Notes.

[] Designates Metric Conversions

NOMINAL SIZES 2-5 TONS [7.0-17.6 kW]

Model RGEA14 Series	048ACT081AA	048ACT08XAA	048ACT101AA	048ACT10XAA
Cooling Performance¹				CONTINUED →
EER/SEER ²	11/14	11/14	11/14	11/14
Nominal CFM/AHRI Rated CFM [L/s]	1600/1550 [755/731]	1600/1550 [755/731]	1600/1550 [755/731]	1600/1550 [755/731]
AHRI Net Cooling Capacity Btu [kW]	44,500 [13.04]	44,500 [13.04]	44,500 [13.04]	44,500 [13.04]
Net Sensible Capacity Btu [kW]	31,920 [9.35]	31,920 [9.35]	31,920 [9.35]	31,920 [9.35]
Net Latent Capacity Btu [kW]	12,580 [3.69]	12,580 [3.69]	12,580 [3.69]	12,580 [3.69]
Net System Power kW	3.89	3.89	3.89	3.89
Heating Performance (Gas)³				
Heating Input Btu [kW]	80,000 [23.44]	80,000 [23.44]	100,000 [29.3]	100,000 [29.3]
Heating Output Btu [kW]	65,000 [19.04]	65,000 [19.04]	81,000 [23.73]	81,000 [23.73]
Temperature Rise Range °F [°C]	35-65 [19.4-36.1]	35-65 [19.4-36.1]	45-75 [25-41.7]	45-75 [25-41.7]
AFUE % ⁴	81	81	81	81
Steady State Efficiency (%)	82	82	82	82
No. Burners	4	4	4	4
No. Stages	1	1	1	1
Gas Connection Pipe Size in. [mm]	0.5 [12.7]	0.5 [12.7]	0.5 [12.7]	0.5 [12.7]
Compressor				
No./Type	1/Scroll	1/Scroll	1/Scroll	1/Scroll
Outdoor Sound Rating (dB)⁵				
	78	78	78	78
Outdoor Coil—Fin Type				
Tube Type	Louvered	Louvered	Louvered	Louvered
MicroChannel Depth in. [mm]	MicroChannel	MicroChannel	MicroChannel	MicroChannel
Face Area sq. ft. [sq. m]	0.71 [18]	0.71 [18]	0.71 [18]	0.71 [18]
Rows / FPI [FPcm]	16.3 [1.51]	16.3 [1.51]	16.3 [1.51]	16.3 [1.51]
	1 / 23 [9]	1 / 23 [9]	1 / 23 [9]	1 / 23 [9]
Indoor Coil—Fin Type				
Tube Type	Louvered	Louvered	Louvered	Louvered
MicroChannel Depth in. [mm]	MicroChannel	MicroChannel	MicroChannel	MicroChannel
Face Area sq. ft. [sq. m]	1 [25.4]	1 [25.4]	1 [25.4]	1 [25.4]
Rows / FPI [FPcm]	4.1 [0.38]	4.1 [0.38]	4.1 [0.38]	4.1 [0.38]
	1 / 20 [8]	1 / 20 [8]	1 / 20 [8]	1 / 20 [8]
Refrigerant Control	TX Valves	TX Valves	TX Valves	TX Valves
Drain Connection No./Size in. [mm]	1/0.75 [19.05]	1/0.75 [19.05]	1/0.75 [19.05]	1/0.75 [19.05]
Outdoor Fan—Type				
No. Used/Diameter in. [mm]	Propeller	Propeller	Propeller	Propeller
Drive Type/No. Speeds	1/22 [558.8]	1/22 [558.8]	1/22 [558.8]	1/22 [558.8]
CFM [L/s]	Direct/1	Direct/1	Direct/1	Direct/1
No. Motors/HP	3300 [1557]	3300 [1557]	3300 [1557]	3300 [1557]
Motor RPM	1 at 1/3 HP	1 at 1/3 HP	1 at 1/3 HP	1 at 1/3 HP
	1075	1075	1075	1075
Indoor Fan—Type				
No. Used/Diameter in. [mm]	FC Centrifugal	FC Centrifugal	FC Centrifugal	FC Centrifugal
Drive Type	1/12x9 [305x229]	1/12x9 [305x229]	1/12x9 [305x229]	1/12x9 [305x229]
No. Speeds	Direct	Direct	Direct	Direct
No. Motors	Multiple	Multiple	Multiple	Multiple
Motor HP	1	1	1	1
Motor RPM	3/4	3/4	3/4	3/4
Motor Frame Size	1075	1075	1075	1075
	48	48	48	48
Filter—Type				
Furnished	Field Supplied	Field Supplied	Field Supplied	Field Supplied
(NO.) Size Recommended in. [mm x mm x mm]	No	No	No	No
	(1)1x24x24 [25x610x610]	(1)1x24x24 [25x610x610]	(1)1x24x24 [25x610x610]	(1)1x24x24 [25x610x610]
Refrigerant Charge Oz. [g]				
	69.3 [1965]	69.3 [1965]	69.3 [1965]	69.3 [1965]
Weights				
Net Weight lbs. [kg]	477 [216]	477 [216]	482 [219]	482 [219]
Ship Weight lbs. [kg]	487 [221]	487 [221]	492 [223]	492 [223]

See Page 50 for Notes.

[] Designates Metric Conversions

NOMINAL SIZES 2-5 TONS [7.0-17.6 kW]

Model RGEA14 Series	048ADT101AA	048ADT10XAA	048AJT081AA	048AJT081AB
Cooling Performance¹				CONTINUED 
EER/SEER ²	11/14	11/14	11/14	11/14
Nominal CFM/AHRI Rated CFM [L/s]	1600/1550 [755/731]	1600/1550 [755/731]	1600/1550 [755/731]	1600/1550 [755/731]
AHRI Net Cooling Capacity Btu [kW]	44,500 [13.04]	44,500 [13.04]	44,500 [13.04]	44,500 [13.04]
Net Sensible Capacity Btu [kW]	31,920 [9.35]	31,920 [9.35]	31,920 [9.35]	31,920 [9.35]
Net Latent Capacity Btu [kW]	12,580 [3.69]	12,580 [3.69]	12,580 [3.69]	12,580 [3.69]
Net System Power kW	3.89	3.89	3.89	3.66
Heating Performance (Gas)³				
Heating Input Btu [kW]	100,000 [29.3]	100,000 [29.3]	80,000 [23.44]	80,000 [23.44]
Heating Output Btu [kW]	81,000 [23.73]	81,000 [23.73]	65,000 [19.04]	65,000 [19.04]
Temperature Rise Range °F [°C]	45-75 [25-41.7]	45-75 [25-41.7]	35-65 [19.4-36.1]	35-65 [19.4-36.1]
AFUE % ⁴	81	81	81	81
Steady State Efficiency (%)	82	82	82	82
No. Burners	4	4	4	4
No. Stages	1	1	1	1
Gas Connection Pipe Size in. [mm]	0.5 [12.7]	0.5 [12.7]	0.5 [12.7]	0.5 [12.7]
Compressor				
No./Type	1/Scroll	1/Scroll	1/Scroll	1/Scroll
Outdoor Sound Rating (dB)⁵	78	78	78	78
Outdoor Coil—Fin Type	Louvered	Louvered	Louvered	Louvered
Tube Type	MicroChannel	MicroChannel	MicroChannel	MicroChannel
MicroChannel Depth in. [mm]	0.71 [18]	0.71 [18]	0.71 [18]	0.7 [17.8]
Face Area sq. ft. [sq. m]	16.3 [1.51]	16.3 [1.51]	16.3 [1.51]	16.3 [1.51]
Rows / FPI [FPcm]	1 / 23 [9]	1 / 23 [9]	1 / 23 [9]	1 / 23 [9]
Indoor Coil—Fin Type	Louvered	Louvered	Louvered	Louvered
Tube Type	MicroChannel	MicroChannel	MicroChannel	MicroChannel
MicroChannel Depth in. [mm]	1 [25.4]	1 [25.4]	1 [25.4]	1.26 [32]
Face Area sq. ft. [sq. m]	4.1 [0.38]	4.1 [0.38]	4.1 [0.38]	4.1 [0.38]
Rows / FPI [FPcm]	1 / 20 [8]	1 / 20 [8]	1 / 20 [8]	1 / 20 [8]
Refrigerant Control	TX Valves	TX Valves	TX Valves	TX Valves
Drain Connection No./Size in. [mm]	1/0.75 [19.05]	1/0.75 [19.05]	1/0.75 [19.05]	1/0.75 [19.05]
Outdoor Fan—Type	Propeller	Propeller	Propeller	Propeller
No. Used/Diameter in. [mm]	1/22 [558.8]	1/22 [558.8]	1/22 [558.8]	1/22 [558.8]
Drive Type/No. Speeds	Direct/1	Direct/1	Direct/1	Direct/1
CFM [L/s]	3300 [1557]	3300 [1557]	3300 [1557]	3300 [1557]
No. Motors/HP	1 at 1/3 HP	1 at 1/3 HP	1 at 1/3 HP	1 at 1/3 HP
Motor RPM	1075	1075	1075	1075
Indoor Fan—Type	FC Centrifugal	FC Centrifugal	FC Centrifugal	FC Centrifugal
No. Used/Diameter in. [mm]	1/12x9 [305x229]	1/12x9 [305x229]	1/12x9 [305x229]	1/12x9 [305x229]
Drive Type	Direct	Direct	Direct	Direct
No. Speeds	Multiple	Multiple	Multiple	Multiple
No. Motors	1	1	1	1
Motor HP	3/4	3/4	3/4	3/4
Motor RPM	1075	1075	1075	1075
Motor Frame Size	48	48	48	48
Filter—Type	Field Supplied	Field Supplied	Field Supplied	Field Supplied
Furnished	No	No	No	No
(NO.) Size Recommended in. [mm x mm x mm]	(1)1x24x24 [25x610x610]	(1)1x24x24 [25x610x610]	(1)1x24x24 [25x610x610]	(1)1x24x24 [25x610x610]
Refrigerant Charge Oz. [g]	69.3 [1965]	69.3 [1965]	69.3 [1965]	85.3 [2418]
Weights				
Net Weight lbs. [kg]	482 [219]	482 [219]	477 [216]	492 [223]
Ship Weight lbs. [kg]	492 [223]	492 [223]	487 [221]	502 [228]

See Page 50 for Notes.

[] Designates Metric Conversions

NOMINAL SIZES 2-5 TONS [7.0-17.6 kW]

Model RGEA14 Series	048AJT08XAA	048AJT08XAB	048AJT101AA	048AJT101AB
Cooling Performance¹				CONTINUED →
EER/SEER ²	11/14	11/14	11/14	11/14
Nominal CFM/AHRI Rated CFM [L/s]	1600/1550 [755/731]	1600/1550 [755/731]	1600/1550 [755/731]	1600/1550 [755/731]
AHRI Net Cooling Capacity Btu [kW]	44,500 [13.04]	44,500 [13.04]	44,500 [13.04]	44,500 [13.04]
Net Sensible Capacity Btu [kW]	31,920 [9.35]	31,920 [9.35]	31,920 [9.35]	31,920 [9.35]
Net Latent Capacity Btu [kW]	12,580 [3.69]	12,580 [3.69]	12,580 [3.69]	12,580 [3.69]
Net System Power kW	3.89	3.66	3.89	3.66
Heating Performance (Gas)³				
Heating Input Btu [kW]	80,000 [23.44]	80,000 [23.44]	100,000 [29.3]	100,000 [29.3]
Heating Output Btu [kW]	65,000 [19.04]	65,000 [19.04]	81,000 [23.73]	81,000 [23.73]
Temperature Rise Range °F [°C]	35-65 [19.4-36.1]	35-65 [19.4-36.1]	45-75 [25-41.7]	45-75 [25-41.7]
AFUE % ⁴	81	81	81	81
Steady State Efficiency (%)	82	82	82	82
No. Burners	4	4	4	4
No. Stages	1	1	1	1
Gas Connection Pipe Size in. [mm]	0.5 [12.7]	0.5 [12.7]	0.5 [12.7]	0.5 [12.7]
Compressor				
No./Type	1/Scroll	1/Scroll	1/Scroll	1/Scroll
Outdoor Sound Rating (dB)⁵	78	78	78	78
Outdoor Coil—Fin Type	Louvered	Louvered	Louvered	Louvered
Tube Type	MicroChannel	MicroChannel	MicroChannel	MicroChannel
MicroChannel Depth in. [mm]	0.71 [18]	0.7 [17.8]	0.71 [18]	0.7 [17.8]
Face Area sq. ft. [sq. m]	16.3 [1.51]	16.3 [1.51]	16.3 [1.51]	16.3 [1.51]
Rows / FPI [FPcm]	1 / 23 [9]	1 / 23 [9]	1 / 23 [9]	1 / 23 [9]
Indoor Coil—Fin Type	Louvered	Louvered	Louvered	Louvered
Tube Type	MicroChannel	MicroChannel	MicroChannel	MicroChannel
MicroChannel Depth in. [mm]	1 [25.4]	1.26 [32]	1 [25.4]	1.26 [32]
Face Area sq. ft. [sq. m]	4.1 [0.38]	4.1 [0.38]	4.1 [0.38]	4.1 [0.38]
Rows / FPI [FPcm]	1 / 20 [8]	1 / 20 [8]	1 / 20 [8]	1 / 20 [8]
Refrigerant Control	TX Valves	TX Valves	TX Valves	TX Valves
Drain Connection No./Size in. [mm]	1/0.75 [19.05]	1/0.75 [19.05]	1/0.75 [19.05]	1/0.75 [19.05]
Outdoor Fan—Type	Propeller	Propeller	Propeller	Propeller
No. Used/Diameter in. [mm]	1/22 [558.8]	1/22 [558.8]	1/22 [558.8]	1/22 [558.8]
Drive Type/No. Speeds	Direct/1	Direct/1	Direct/1	Direct/1
CFM [L/s]	3300 [1557]	3300 [1557]	3300 [1557]	3300 [1557]
No. Motors/HP	1 at 1/3 HP	1 at 1/3 HP	1 at 1/3 HP	1 at 1/3 HP
Motor RPM	1075	1075	1075	1075
Indoor Fan—Type	FC Centrifugal	FC Centrifugal	FC Centrifugal	FC Centrifugal
No. Used/Diameter in. [mm]	1/12x9 [305x229]	1/12x9 [305x229]	1/12x9 [305x229]	1/12x9 [305x229]
Drive Type	Direct	Direct	Direct	Direct
No. Speeds	Multiple	Multiple	Multiple	Multiple
No. Motors	1	1	1	1
Motor HP	3/4	3/4	3/4	3/4
Motor RPM	1075	1075	1075	1075
Motor Frame Size	48	48	48	48
Filter—Type	Field Supplied	Field Supplied	Field Supplied	Field Supplied
Furnished	No	No	No	No
(NO.) Size Recommended in. [mm x mm x mm]	(1)1x24x24 [25x610x610]	(1)1x24x24 [25x610x610]	(1)1x24x24 [25x610x610]	(1)1x24x24 [25x610x610]
Refrigerant Charge Oz. [g]	69.3 [1965]	85.3 [2418]	69.3 [1965]	85.3 [2418]
Weights				
Net Weight lbs. [kg]	477 [216]	492 [223]	482 [219]	497 [225]
Ship Weight lbs. [kg]	487 [221]	502 [228]	492 [223]	507 [230]

See Page 50 for Notes.

[] Designates Metric Conversions

NOMINAL SIZES 2-5 TONS [7.0-17.6 kW]

Model RGEA14 Series	048AJT10XAA	048AJT10XAB
Cooling Performance¹		
EER/SEER ²	11/14	11/14
Nominal CFM/AHRI Rated CFM [L/s]	1600/1550 [755/731]	1600/1550 [755/731]
AHRI Net Cooling Capacity Btu [kW]	44,500 [13.04]	44,500 [13.04]
Net Sensible Capacity Btu [kW]	31,920 [9.35]	31,920 [9.35]
Net Latent Capacity Btu [kW]	12,580 [3.69]	12,580 [3.69]
Net System Power kW	3.89	3.66
Heating Performance (Gas)³		
Heating Input Btu [kW]	100,000 [29.3]	100,000 [29.3]
Heating Output Btu [kW]	81,000 [23.73]	81,000 [23.73]
Temperature Rise Range °F [°C]	45-75 [25-41.7]	45-75 [25-41.7]
AFUE % ⁴	81	81
Steady State Efficiency (%)	82	82
No. Burners	4	4
No. Stages	1	1
Gas Connection Pipe Size in. [mm]	0.5 [12.7]	0.5 [12.7]
Compressor		
No./Type	1/Scroll	1/Scroll
Outdoor Sound Rating (dB)⁵		
	78	78
Outdoor Coil—Fin Type		
Tube Type	Louvered	Louvered
MicroChannel Depth in. [mm]	MicroChannel	MicroChannel
Face Area sq. ft. [sq. m]	0.71 [18]	0.7 [17.8]
Rows / FPI [FPcm]	16.3 [1.51]	16.3 [1.51]
	1 / 23 [9]	1 / 23 [9]
Indoor Coil—Fin Type		
Tube Type	Louvered	Louvered
MicroChannel Depth in. [mm]	MicroChannel	MicroChannel
Face Area sq. ft. [sq. m]	1 [25.4]	1.26 [32]
Rows / FPI [FPcm]	4.1 [0.38]	4.1 [0.38]
Refrigerant Control	1 / 20 [8]	1 / 20 [8]
Drain Connection No./Size in. [mm]	TX Valves	TX Valves
	1/0.75 [19.05]	1/0.75 [19.05]
Outdoor Fan—Type		
No. Used/Diameter in. [mm]	Propeller	Propeller
Drive Type/No. Speeds	1/22 [558.8]	1/22 [558.8]
CFM [L/s]	Direct/1	Direct/1
No. Motors/HP	3300 [1557]	3300 [1557]
Motor RPM	1 at 1/3 HP	1 at 1/3 HP
	1075	1075
Indoor Fan—Type		
No. Used/Diameter in. [mm]	FC Centrifugal	FC Centrifugal
Drive Type	1/12x9 [305x229]	1/12x9 [305x229]
No. Speeds	Direct	Direct
No. Motors	Multiple	Multiple
Motor HP	1	1
Motor RPM	3/4	3/4
Motor Frame Size	1075	1075
	48	48
Filter—Type		
Furnished	Field Supplied	Field Supplied
(NO.) Size Recommended in. [mm x mm x mm]	No	No
	(1)1x24x24 [25x610x610]	(1)1x24x24 [25x610x610]
Refrigerant Charge Oz. [g]		
	69.3 [1965]	85.3 [2418]
Weights		
Net Weight lbs. [kg]	482 [219]	497 [225]
Ship Weight lbs. [kg]	492 [223]	507 [230]

CONTINUED →

See Page 50 for Notes.

[] Designates Metric Conversions

NOMINAL SIZES 2-5 TONS [7.0-17.6 kW]

Model RGEA14 Series	060ACT101AA	060ACT10XAA	060ADT101AA	060ADT10XAA
Cooling Performance¹				CONTINUED →
EER/SEER ²	11/14	11/14	11/14	11/14
Nominal CFM/AHRI Rated CFM [L/s]	2000/1700 [944/802]	2000/1700 [944/802]	2000/1700 [944/802]	2000/1700 [944/802]
AHRI Net Cooling Capacity Btu [kW]	54,500 [15.97]	54,500 [15.97]	54,500 [15.97]	54,500 [15.97]
Net Sensible Capacity Btu [kW]	37,760 [11.07]	37,760 [11.07]	37,760 [11.07]	37,760 [11.07]
Net Latent Capacity Btu [kW]	16,740 [4.90]	16,740 [4.90]	16,740 [4.90]	16,740 [4.90]
Net System Power kW	4.94	4.94	4.94	4.94
Heating Performance (Gas)³				
Heating Input Btu [kW]	100,000 [29.3]	100,000 [29.3]	100,000 [29.3]	100,000 [29.3]
Heating Output Btu [kW]	81,000 [23.73]	81,000 [23.73]	81,000 [23.73]	81,000 [23.73]
Temperature Rise Range °F [°C]	45-75 [25-41.7]	45-75 [25-41.7]	45-75 [25-41.7]	45-75 [25-41.7]
AFUE % ⁴	81	81	81	81
Steady State Efficiency (%)	82	82	82	82
No. Burners	5	5	5	5
No. Stages	1	1	1	1
Gas Connection Pipe Size in. [mm]	0.5 [12.7]	0.5 [12.7]	0.5 [12.7]	0.5 [12.7]
Compressor				
No./Type	1/Scroll	1/Scroll	1/Scroll	1/Scroll
Outdoor Sound Rating (dB)⁵				
	79	79	79	79
Outdoor Coil—Fin Type				
Tube Type	Louvered	Louvered	Louvered	Louvered
MicroChannel Depth in. [mm]	MicroChannel	MicroChannel	MicroChannel	MicroChannel
Face Area sq. ft. [sq. m]	1 [25.4]	1 [25.4]	1 [25.4]	1 [25.4]
Rows / FPI [FPcm]	15.3 [1.42]	15.3 [1.42]	15.3 [1.42]	15.3 [1.42]
	1 / 23 [9]	1 / 23 [9]	1 / 23 [9]	1 / 23 [9]
Indoor Coil—Fin Type				
Tube Type	Louvered	Louvered	Louvered	Louvered
MicroChannel Depth in. [mm]	MicroChannel	MicroChannel	MicroChannel	MicroChannel
Face Area sq. ft. [sq. m]	1.26 [32]	1.26 [32]	1.26 [32]	1.26 [32]
Rows / FPI [FPcm]	4 [0.37]	4 [0.37]	4 [0.37]	4 [0.37]
	1 / 20 [8]	1 / 20 [8]	1 / 20 [8]	1 / 20 [8]
Refrigerant Control	TX Valves	TX Valves	TX Valves	TX Valves
Drain Connection No./Size in. [mm]	1/0.75 [19.05]	1/0.75 [19.05]	1/0.75 [19.05]	1/0.75 [19.05]
Outdoor Fan—Type				
No. Used/Diameter in. [mm]	Propeller	Propeller	Propeller	Propeller
Drive Type/No. Speeds	1/22 [558.8]	1/22 [558.8]	1/22 [558.8]	1/22 [558.8]
CFM [L/s]	Direct/1	Direct/1	Direct/1	Direct/1
No. Motors/HP	3400 [1604]	3400 [1604]	3400 [1604]	3400 [1604]
Motor RPM	1 at 1/3 HP	1 at 1/3 HP	1 at 1/3 HP	1 at 1/3 HP
	1075	1075	1075	1075
Indoor Fan—Type				
No. Used/Diameter in. [mm]	FC Centrifugal	FC Centrifugal	FC Centrifugal	FC Centrifugal
Drive Type	1/12x9 [305x229]	1/12x9 [305x229]	1/12x9 [305x229]	1/12x9 [305x229]
No. Speeds	Direct	Direct	Direct	Direct
No. Motors	Multiple	Multiple	Multiple	Multiple
Motor HP	1	1	1	1
Motor RPM	1	1	1	1
Motor Frame Size	1075	1075	1075	1075
	48	48	48	48
Filter—Type				
Furnished	Field Supplied	Field Supplied	Field Supplied	Field Supplied
(NO.) Size Recommended in. [mm x mm x mm]	No	No	No	No
	(1)1x24x30 [25x610x762]	(1)1x24x30 [25x610x762]	(1)1x24x30 [25x610x762]	(1)1x24x30 [25x610x762]
Refrigerant Charge Oz. [g]				
	83.1 [2356]	83.1 [2356]	83.1 [2356]	83.1 [2356]
Weights				
Net Weight lbs. [kg]	512 [232]	512 [232]	512 [232]	512 [232]
Ship Weight lbs. [kg]	522 [237]	522 [237]	522 [237]	522 [237]

See Page 50 for Notes.

[] Designates Metric Conversions

NOMINAL SIZES 2-5 TONS [7.0-17.6 kW]

Model RGEA14 Series	060AJT101AA	060AJT10XAA
Cooling Performance¹		
EER/SEER ²	11/14	11/14
Nominal CFM/AHRI Rated CFM [L/s]	2000/1700 [944/802]	2000/1700 [944/802]
AHRI Net Cooling Capacity Btu [kW]	54,500 [15.97]	54,500 [15.97]
Net Sensible Capacity Btu [kW]	37,760 [11.07]	37,760 [11.07]
Net Latent Capacity Btu [kW]	16,740 [4.90]	16,740 [4.90]
Net System Power kW	4.94	4.94
Heating Performance (Gas)³		
Heating Input Btu [kW]	100,000 [29.3]	100,000 [29.3]
Heating Output Btu [kW]	81,000 [23.73]	81,000 [23.73]
Temperature Rise Range °F [°C]	45-75 [25-41.7]	45-75 [25-41.7]
AFUE % ⁴	81	81
Steady State Efficiency (%)	82	82
No. Burners	5	5
No. Stages	1	1
Gas Connection Pipe Size in. [mm]	0.5 [12.7]	0.5 [12.7]
Compressor		
No./Type	1/Scroll	1/Scroll
Outdoor Sound Rating (dB)⁵		
	79	79
Outdoor Coil—Fin Type		
Tube Type	Louvered	Louvered
MicroChannel Depth in. [mm]	MicroChannel	MicroChannel
Face Area sq. ft. [sq. m]	1 [25.4]	1 [25.4]
Rows / FPI [FPcm]	15.3 [1.42]	15.3 [1.42]
	1 / 23 [9]	1 / 23 [9]
Indoor Coil—Fin Type		
Tube Type	Louvered	Louvered
MicroChannel Depth in. [mm]	MicroChannel	MicroChannel
Face Area sq. ft. [sq. m]	1.26 [32]	1.26 [32]
Rows / FPI [FPcm]	4 [0.37]	4 [0.37]
	1 / 20 [8]	1 / 20 [8]
Refrigerant Control	TX Valves	TX Valves
Drain Connection No./Size in. [mm]	1/0.75 [19.05]	1/0.75 [19.05]
Outdoor Fan—Type		
No. Used/Diameter in. [mm]	Propeller	Propeller
Drive Type/No. Speeds	1/22 [558.8]	1/22 [558.8]
CFM [L/s]	Direct/1	Direct/1
No. Motors/HP	3400 [1604]	3400 [1604]
Motor RPM	1 at 1/3 HP	1 at 1/3 HP
	1075	1075
Indoor Fan—Type		
No. Used/Diameter in. [mm]	FC Centrifugal	FC Centrifugal
Drive Type	1/12x9 [305x229]	1/12x9 [305x229]
No. Speeds	Direct	Direct
No. Motors	Multiple	Multiple
Motor HP	1	1
Motor RPM	1	1
Motor Frame Size	1075	1075
	48	48
Filter—Type		
Furnished	Field Supplied	Field Supplied
(NO.) Size Recommended in. [mm x mm x mm]	No	No
	(1)1x24x30 [25x610x762]	(1)1x24x30 [25x610x762]
Refrigerant Charge Oz. [g]		
	83.1 [2356]	83.1 [2356]
Weights		
Net Weight lbs. [kg]	512 [232]	512 [232]
Ship Weight lbs. [kg]	522 [237]	522 [237]

CONTINUED →

See Page 50 for Notes.

[] Designates Metric Conversions



NOMINAL SIZES 2-5 TONS [7.0-17.6 kW]

Model RGEA14 Series	060AJT101AB	060AJT10XAB
Cooling Performance¹		
EER/SEER ²	14	14
Nominal CFM/AHRI Rated CFM [L/s]	11	11
AHRI Net Cooling Capacity Btu [kW]	1250/1850 [590/873]	1250/1850 [590/873]
Net Sensible Capacity Btu [kW]	54,500 [15.97]	54,500 [15.97]
Net Latent Capacity Btu [kW]	37,760 [11.07]	37,760 [11.07]
Net System Power kW	16,740 [4.90]	16,740 [4.90]
Heating Performance (Gas)³		
Heating Input Btu [kW]	2.14/5.02	2.14/5.02
Heating Output Btu [kW]	100,000 [29.3]	100,000 [29.3]
Temperature Rise Range °F [°C]	81,000 [23.73]	81,000 [23.73]
AFUE % ⁴	45-75 [25-41.7]	45-75 [25-41.7]
Steady State Efficiency (%)	81	81
No. Burners	82	82
No. Stages	5	5
Gas Connection Pipe Size in. [mm]	1	1
Compressor		
No./Type	0.5 [12.7] 1/Scroll	0.5 [12.7] 1/Scroll
Outdoor Sound Rating (dB)⁵		
	78	78
Outdoor Coil—Fin Type		
Tube Type	Louvered	Louvered
MicroChannel Depth in. [mm]	MicroChannel	MicroChannel
Face Area sq. ft. [sq. m]	1 [25.4]	1 [25.4]
Rows / FPI [FPcm]	15.3 [1.42]	15.3 [1.42]
	1 / 23 [9]	1 / 23 [9]
Indoor Coil—Fin Type		
Tube Type	Louvered	Louvered
MicroChannel Depth in. [mm]	MicroChannel	MicroChannel
Face Area sq. ft. [sq. m]	1.26 [32]	1.26 [32]
Rows / FPI [FPcm]	4 [0.37]	4 [0.37]
	1 / 20 [8]	1 / 20 [8]
Refrigerant Control	TX Valves	TX Valves
Drain Connection No./Size in. [mm]	1/0.75 [19.05]	1/0.75 [19.05]
Outdoor Fan—Type		
No. Used/Diameter in. [mm]	Propeller	Propeller
Drive Type/No. Speeds	1/22 [558.8]	1/22 [558.8]
CFM [L/s]	Direct/1	Direct/1
No. Motors/HP	3300 [1557]	3300 [1557]
Motor RPM	1 at 1/3 HP	1 at 1/3 HP
	1075	1075
Indoor Fan—Type		
No. Used/Diameter in. [mm]	FC Centrifugal	FC Centrifugal
Drive Type	1/12x9 [305x229]	1/12x9 [305x229]
No. Speeds	Direct	Direct
No. Motors	Multiple	Multiple
Motor HP	1	1
Motor RPM	1	1
Motor Frame Size	1075	1075
	48	48
Filter—Type		
Furnished	Field Supplied	Field Supplied
(NO.) Size Recommended in. [mm x mm x mm]	No	No
	(1)1x24x30 [25x610x762]	(1)1x24x30 [25x610x762]
Refrigerant Charge Oz. [g]		
	89.6 [2540]	89.6 [2540]
Weights		
Net Weight lbs. [kg]	515 [234]	515 [234]
Ship Weight lbs. [kg]	525 [238]	525 [238]

See Page 50 for Notes.

[] Designates Metric Conversions

NOMINAL SIZES 2-5 TONS [7.0-17.6 kW]

Model RGEA15 Series	024AJT061AA	024AJT06XAA	024AJT081AA	024AJT08XAA
Cooling Performance¹				CONTINUED →
EER/SEER ²	11.7/14.3	11.7/14.3	11.7/14.3	11.7/14.3
Nominal CFM/AHRI Rated CFM [L/s]	800/900 [378/425]	800/900 [378/425]	800/900 [378/425]	800/900 [378/425]
AHRI Net Cooling Capacity Btu [kW]	23,600 [6.91]	23,600 [6.91]	23,600 [6.91]	23,600 [6.91]
Net Sensible Capacity Btu [kW]	17,790 [5.21]	17,790 [5.21]	17,790 [5.21]	17,790 [5.21]
Net Latent Capacity Btu [kW]	5,810 [1.70]	5,810 [1.70]	5,810 [1.70]	5,810 [1.70]
Net System Power kW	2.03	2.03	2.03	2.03
Heating Performance (Gas)³				
Heating Input Btu [kW]	60,000 [17.58]	60,000 [17.58]	80,000 [23.44]	80,000 [23.44]
Heating Output Btu [kW]	48,000 [14.06]	48,000 [14.06]	65,000 [19.04]	65,000 [19.04]
Temperature Rise Range °F [°C]	40-70 [22.2-38.9]	40-70 [22.2-38.9]	35-65 [19.4-36.1]	35-65 [19.4-36.1]
AFUE % ⁴	81	81	81	81
Steady State Efficiency (%)	82	82	82	82
No. Burners	2	2	2	2
No. Stages	1	1	1	1
Gas Connection Pipe Size in. [mm]	0.5 [12.7]	0.5 [12.7]	0.5 [12.7]	0.5 [12.7]
Compressor				
No./Type	1/Scroll	1/Scroll	1/Scroll	1/Scroll
Outdoor Sound Rating (dB)⁵	76	76	76	76
Outdoor Coil—Fin Type	Louvered	Louvered	Louvered	Louvered
Tube Type	MicroChannel	MicroChannel	MicroChannel	MicroChannel
MicroChannel Depth in. [mm]	0.71 [18]	0.71 [18]	0.71 [18]	0.71 [18]
Face Area sq. ft. [sq. m]	7.1 [0.66]	7.1 [0.66]	7.1 [0.66]	7.1 [0.66]
Rows / FPI [FPcm]	1 / 23 [9]	1 / 23 [9]	1 / 23 [9]	1 / 23 [9]
Indoor Coil—Fin Type	Louvered	Louvered	Louvered	Louvered
Tube Type	MicroChannel	MicroChannel	MicroChannel	MicroChannel
MicroChannel Depth in. [mm]	1 [25.4]	1 [25.4]	1 [25.4]	1 [25.4]
Face Area sq. ft. [sq. m]	3.6 [0.33]	3.6 [0.33]	3.6 [0.33]	3.6 [0.33]
Rows / FPI [FPcm]	1 / 17 [7]	1 / 17 [7]	1 / 17 [7]	1 / 17 [7]
Refrigerant Control	TX Valves	TX Valves	TX Valves	TX Valves
Drain Connection No./Size in. [mm]	1/0.75 [19.05]	1/0.75 [19.05]	1/0.75 [19.05]	1/0.75 [19.05]
Outdoor Fan—Type	Propeller	Propeller	Propeller	Propeller
No. Used/Diameter in. [mm]	1/22 [558.8]	1/22 [558.8]	1/22 [558.8]	1/22 [558.8]
Drive Type/No. Speeds	Direct/1	Direct/1	Direct/1	Direct/1
CFM [L/s]	2500 [1180]	2500 [1180]	2500 [1180]	2500 [1180]
No. Motors/HP	1 at 1/3 HP	1 at 1/3 HP	1 at 1/3 HP	1 at 1/3 HP
Motor RPM	1075	1075	1075	1075
Indoor Fan—Type	FC Centrifugal	FC Centrifugal	FC Centrifugal	FC Centrifugal
No. Used/Diameter in. [mm]	1/10x9 [254x229]	1/10x9 [254x229]	1/10x9 [254x229]	1/10x9 [254x229]
Drive Type	Direct	Direct	Direct	Direct
No. Speeds	Multiple	Multiple	Multiple	Multiple
No. Motors	1	1	1	1
Motor HP	1/3	1/3	1/3	1/3
Motor RPM	1075	1075	1075	1075
Motor Frame Size	48	48	48	48
Filter—Type	Field Supplied	Field Supplied	Field Supplied	Field Supplied
Furnished	No	No	No	No
(NO.) Size Recommended in. [mm x mm x mm]	(1)1x20x20 [25x508x508]	(1)1x20x20 [25x508x508]	(1)1x20x20 [25x508x508]	(1)1x20x20 [25x508x508]
Refrigerant Charge Oz. [g]	42.6 [1208]	42.6 [1208]	42.6 [1208]	42.6 [1208]
Weights				
Net Weight lbs. [kg]	403 [183]	403 [183]	408 [185]	408 [185]
Ship Weight lbs. [kg]	413 [187]	413 [187]	418 [190]	418 [190]

See Page 50 for Notes.

[] Designates Metric Conversions

NOMINAL SIZES 2-5 TONS [7.0-17.6 kW]

Model RGEA15 Series	024AJV061AA	024AJV061AB	024AJV06XAA	024AJV06XAB
Cooling Performance¹				CONTINUED →
EER/SEER ²	11.7/14.3	11.7/14.3	11.7/14.3	11.7/14.3
Nominal CFM/AHRI Rated CFM [L/s]	800/900 [378/425]	800/900 [378/425]	800/900 [378/425]	800/900 [378/425]
AHRI Net Cooling Capacity Btu [kW]	23,600 [6.91]	23,600 [6.91]	23,600 [6.91]	23,600 [6.91]
Net Sensible Capacity Btu [kW]	17,790 [5.21]	17,790 [5.21]	17,790 [5.21]	17,790 [5.21]
Net Latent Capacity Btu [kW]	5,810 [1.70]	5,810 [1.70]	5,810 [1.70]	5,810 [1.70]
Net System Power kW	2.03	2.03	2.03	2.03
Heating Performance (Gas)³				
Heating Input Btu [kW]	60,000 [17.58]	60,000 [17.58]	60,000 [17.58]	60,000 [17.58]
Heating Output Btu [kW]	48,000 [14.06]	48,000 [14.06]	48,000 [14.06]	48,000 [14.06]
Temperature Rise Range °F [°C]	40-70 [22.2-38.9]	40-70 [22.2-38.9]	40-70 [22.2-38.9]	40-70 [22.2-38.9]
AFUE % ⁴	81	81	81	81
Steady State Efficiency (%)	82	82	82	82
No. Burners	2	2	2	2
No. Stages	1	1	1	1
Gas Connection Pipe Size in. [mm]	0.5 [12.7]	0.5 [12.7]	0.5 [12.7]	0.5 [12.7]
Compressor				
No./Type	1/Scroll	1/Scroll	1/Scroll	1/Scroll
Outdoor Sound Rating (dB)⁵	76	76	76	76
Outdoor Coil—Fin Type	Louvered	Louvered	Louvered	Louvered
Tube Type	MicroChannel	MicroChannel	MicroChannel	MicroChannel
MicroChannel Depth in. [mm]	0.71 [18]	0.71 [18]	0.71 [18]	0.71 [18]
Face Area sq. ft. [sq. m]	7.1 [0.66]	7.1 [0.66]	7.1 [0.66]	7.1 [0.66]
Rows / FPI [FPcm]	1 / 23 [9]	1 / 23 [9]	1 / 23 [9]	1 / 23 [9]
Indoor Coil—Fin Type	Louvered	Louvered	Louvered	Louvered
Tube Type	MicroChannel	MicroChannel	MicroChannel	MicroChannel
MicroChannel Depth in. [mm]	1 [25.4]	1 [25.4]	1 [25.4]	1 [25.4]
Face Area sq. ft. [sq. m]	3.6 [0.33]	3.6 [0.33]	3.6 [0.33]	3.6 [0.33]
Rows / FPI [FPcm]	1 / 17 [7]	1 / 17 [7]	1 / 17 [7]	1 / 17 [7]
Refrigerant Control	TX Valves	TX Valves	TX Valves	TX Valves
Drain Connection No./Size in. [mm]	1/0.75 [19.05]	1/0.75 [19.05]	1/0.75 [19.05]	1/0.75 [19.05]
Outdoor Fan—Type	Propeller	Propeller	Propeller	Propeller
No. Used/Diameter in. [mm]	1/22 [558.8]	1/22 [558.8]	1/22 [558.8]	1/22 [558.8]
Drive Type/No. Speeds	Direct/1	Direct/1	Direct/1	Direct/1
CFM [L/s]	2500 [1180]	2500 [1180]	2500 [1180]	2500 [1180]
No. Motors/HP	1 at 1/3 HP	1 at 1/3 HP	1 at 1/3 HP	1 at 1/3 HP
Motor RPM	1075	1075	1075	1075
Indoor Fan—Type	FC Centrifugal	FC Centrifugal	FC Centrifugal	FC Centrifugal
No. Used/Diameter in. [mm]	1/10x9 [254x229]	1/10x9 [254x229]	1/10x9 [254x229]	1/10x9 [254x229]
Drive Type	Direct	Direct	Direct	Direct
No. Speeds	Multiple	Multiple	Multiple	Multiple
No. Motors	1	1	1	1
Motor HP	1/2	1/2	1/2	1/2
Motor RPM	1050	1050	1050	1050
Motor Frame Size	48	48	48	48
Filter—Type	Field Supplied	Field Supplied	Field Supplied	Field Supplied
Furnished	No	No	No	No
(NO.) Size Recommended in. [mm x mm x mm]	(1)1x20x20 [25x508x508]	(1)1x20x20 [25x508x508]	(1)1x20x20 [25x508x508]	(1)1x20x20 [25x508x508]
Refrigerant Charge Oz. [g]	42.6 [1208]	42.6 [1208]	42.6 [1208]	42.6 [1208]
Weights				
Net Weight lbs. [kg]	403 [183]	403 [183]	403 [183]	403 [183]
Ship Weight lbs. [kg]	413 [187]	413 [187]	413 [187]	413 [187]

See Page 50 for Notes.

[] Designates Metric Conversions

NOMINAL SIZES 2-5 TONS [7.0-17.6 kW]

Model RGEA15 Series	024AJV081AA	024AJV081AB	024AJV08XAA	024AJV08XAB
Cooling Performance¹				CONTINUED →
EER/SEER ²	11.7/14.3	11.7/14.3	11.7/14.3	11.7/14.3
Nominal CFM/AHRI Rated CFM [L/s]	800/900 [378/425]	800/900 [378/425]	800/900 [378/425]	800/900 [378/425]
AHRI Net Cooling Capacity Btu [kW]	23,600 [6.91]	23,600 [6.91]	23,600 [6.91]	23,600 [6.91]
Net Sensible Capacity Btu [kW]	17,790 [5.21]	17,790 [5.21]	17,790 [5.21]	17,790 [5.21]
Net Latent Capacity Btu [kW]	5,810 [1.70]	5,810 [1.70]	5,810 [1.70]	5,810 [1.70]
Net System Power kW	2.03	2.03	2.03	2.03
Heating Performance (Gas)³				
Heating Input Btu [kW]	80,000 [23.44]	80,000 [23.44]	80,000 [23.44]	80,000 [23.44]
Heating Output Btu [kW]	65,000 [19.04]	65,000 [19.04]	65,000 [19.04]	65,000 [19.04]
Temperature Rise Range °F [°C]	35-65 [19.4-36.1]	35-65 [19.4-36.1]	35-65 [19.4-36.1]	35-65 [19.4-36.1]
AFUE % ⁴	81	81	81	81
Steady State Efficiency (%)	82	82	82	82
No. Burners	2	2	2	2
No. Stages	1	1	1	1
Gas Connection Pipe Size in. [mm]	0.5 [12.7]	0.5 [12.7]	0.5 [12.7]	0.5 [12.7]
Compressor				
No./Type	1/Scroll	1/Scroll	1/Scroll	1/Scroll
Outdoor Sound Rating (dB)⁵	76	76	76	76
Outdoor Coil—Fin Type	Louvered	Louvered	Louvered	Louvered
Tube Type	MicroChannel	MicroChannel	MicroChannel	MicroChannel
MicroChannel Depth in. [mm]	0.71 [18]	0.71 [18]	0.71 [18]	0.71 [18]
Face Area sq. ft. [sq. m]	7.1 [0.66]	7.1 [0.66]	7.1 [0.66]	7.1 [0.66]
Rows / FPI [FPcm]	1 / 23 [9]	1 / 23 [9]	1 / 23 [9]	1 / 23 [9]
Indoor Coil—Fin Type	Louvered	Louvered	Louvered	Louvered
Tube Type	MicroChannel	MicroChannel	MicroChannel	MicroChannel
MicroChannel Depth in. [mm]	1 [25.4]	1 [25.4]	1 [25.4]	1 [25.4]
Face Area sq. ft. [sq. m]	3.6 [0.33]	3.6 [0.33]	3.6 [0.33]	3.6 [0.33]
Rows / FPI [FPcm]	1 / 17 [7]	1 / 17 [7]	1 / 17 [7]	1 / 17 [7]
Refrigerant Control	TX Valves	TX Valves	TX Valves	TX Valves
Drain Connection No./Size in. [mm]	1/0.75 [19.05]	1/0.75 [19.05]	1/0.75 [19.05]	1/0.75 [19.05]
Outdoor Fan—Type	Propeller	Propeller	Propeller	Propeller
No. Used/Diameter in. [mm]	1/22 [558.8]	1/22 [558.8]	1/22 [558.8]	1/22 [558.8]
Drive Type/No. Speeds	Direct/1	Direct/1	Direct/1	Direct/1
CFM [L/s]	2500 [1180]	2500 [1180]	2500 [1180]	2500 [1180]
No. Motors/HP	1 at 1/3 HP	1 at 1/3 HP	1 at 1/3 HP	1 at 1/3 HP
Motor RPM	1075	1075	1075	1075
Indoor Fan—Type	FC Centrifugal	FC Centrifugal	FC Centrifugal	FC Centrifugal
No. Used/Diameter in. [mm]	1/10x9 [254x229]	1/10x9 [254x229]	1/10x9 [254x229]	1/10x9 [254x229]
Drive Type	Direct	Direct	Direct	Direct
No. Speeds	Multiple	Multiple	Multiple	Multiple
No. Motors	1	1	1	1
Motor HP	1/2	1/2	1/2	1/2
Motor RPM	1050	1050	1050	1050
Motor Frame Size	48	48	48	48
Filter—Type	Field Supplied	Field Supplied	Field Supplied	Field Supplied
Furnished	No	No	No	No
(NO.) Size Recommended in. [mm x mm x mm]	(1)1x20x20 [25x508x508]	(1)1x20x20 [25x508x508]	(1)1x20x20 [25x508x508]	(1)1x20x20 [25x508x508]
Refrigerant Charge Oz. [g]	42.6 [1208]	42.6 [1208]	42.6 [1208]	42.6 [1208]
Weights				
Net Weight lbs. [kg]	408 [185]	408 [185]	408 [185]	408 [185]
Ship Weight lbs. [kg]	418 [190]	418 [190]	418 [190]	418 [190]

See Page 50 for Notes.

[] Designates Metric Conversions

NOMINAL SIZES 2-5 TONS [7.0-17.6 kW]

Model RGEA15 Series	030AJT061AA	030AJT06XAA	030AJT081AA	030AJT08XAA
Cooling Performance¹				CONTINUED →
EER/SEER ²	12/15	12/15	12/15	12/15
Nominal CFM/AHRI Rated CFM [L/s]	1000/975 [472/460]	1000/975 [472/460]	1000/975 [472/460]	1000/975 [472/460]
AHRI Net Cooling Capacity Btu [kW]	28,600 [8.38]	28,600 [8.38]	28,600 [8.38]	28,600 [8.38]
Net Sensible Capacity Btu [kW]	21,200 [6.21]	21,200 [6.21]	21,200 [6.21]	21,200 [6.21]
Net Latent Capacity Btu [kW]	7,400 [2.17]	7,400 [2.17]	7,400 [2.17]	7,400 [2.17]
Net System Power kW	2.21	2.21	2.21	2.21
Heating Performance (Gas)³				
Heating Input Btu [kW]	60,000 [17.58]	60,000 [17.58]	80,000 [23.44]	80,000 [23.44]
Heating Output Btu [kW]	48,000 [14.06]	48,000 [14.06]	65,000 [19.04]	65,000 [19.04]
Temperature Rise Range °F [°C]	40-70 [22.2-38.9]	40-70 [22.2-38.9]	35-65 [19.4-36.1]	35-65 [19.4-36.1]
AFUE % ⁴	81	81	81	81
Steady State Efficiency (%)	82	82	82	82
No. Burners	3	3	3	3
No. Stages	1	1	1	1
Gas Connection Pipe Size in. [mm]	0.5 [12.7]	0.5 [12.7]	0.5 [12.7]	0.5 [12.7]
Compressor				
No./Type	1/Scroll	1/Scroll	1/Scroll	1/Scroll
Outdoor Sound Rating (dB)⁵	76	76	76	76
Outdoor Coil—Fin Type	Louvered	Louvered	Louvered	Louvered
Tube Type	MicroChannel	MicroChannel	MicroChannel	MicroChannel
MicroChannel Depth in. [mm]	0.71 [18]	0.71 [18]	0.71 [18]	0.71 [18]
Face Area sq. ft. [sq. m]	9.9 [0.92]	9.9 [0.92]	9.9 [0.92]	9.9 [0.92]
Rows / FPI [FPcm]	1 / 23 [9]	1 / 23 [9]	1 / 23 [9]	1 / 23 [9]
Indoor Coil—Fin Type	Louvered	Louvered	Louvered	Louvered
Tube Type	MicroChannel	MicroChannel	MicroChannel	MicroChannel
MicroChannel Depth in. [mm]	1 [25.4]	1 [25.4]	1 [25.4]	1 [25.4]
Face Area sq. ft. [sq. m]	3.6 [0.33]	3.6 [0.33]	3.6 [0.33]	3.6 [0.33]
Rows / FPI [FPcm]	1 / 17 [7]	1 / 17 [7]	1 / 17 [7]	1 / 17 [7]
Refrigerant Control	TX Valves	TX Valves	TX Valves	TX Valves
Drain Connection No./Size in. [mm]	1/0.75 [19.05]	1/0.75 [19.05]	1/0.75 [19.05]	1/0.75 [19.05]
Outdoor Fan—Type	Propeller	Propeller	Propeller	Propeller
No. Used/Diameter in. [mm]	1/22 [558.8]	1/22 [558.8]	1/22 [558.8]	1/22 [558.8]
Drive Type/No. Speeds	Direct/1	Direct/1	Direct/1	Direct/1
CFM [L/s]	2500 [1180]	2500 [1180]	2500 [1180]	2500 [1180]
No. Motors/HP	1 at 1/3 HP	1 at 1/3 HP	1 at 1/3 HP	1 at 1/3 HP
Motor RPM	1075	1075	1075	1075
Indoor Fan—Type	FC Centrifugal	FC Centrifugal	FC Centrifugal	FC Centrifugal
No. Used/Diameter in. [mm]	1/10x9 [254x229]	1/10x9 [254x229]	1/10x9 [254x229]	1/10x9 [254x229]
Drive Type	Direct	Direct	Direct	Direct
No. Speeds	Multiple	Multiple	Multiple	Multiple
No. Motors	1	1	1	1
Motor HP	1/2	1/2	1/2	1/2
Motor RPM	1075	1075	1075	1075
Motor Frame Size	48	48	48	48
Filter—Type	Field Supplied	Field Supplied	Field Supplied	Field Supplied
Furnished	No	No	No	No
(NO.) Size Recommended in. [mm x mm x mm]	(1)1x24x24 [25x610x610]	(1)1x24x24 [25x610x610]	(1)1x24x24 [25x610x610]	(1)1x24x24 [25x610x610]
Refrigerant Charge Oz. [g]	46.8 [1327]	46.8 [1327]	46.8 [1327]	46.8 [1327]
Weights				
Net Weight lbs. [kg]	403 [183]	403 [183]	408 [185]	408 [185]
Ship Weight lbs. [kg]	413 [187]	413 [187]	418 [190]	418 [190]

See Page 50 for Notes.

[] Designates Metric Conversions

NOMINAL SIZES 2-5 TONS [7.0-17.6 kW]

Model RGEA15 Series	030AJV061AA	030AJV061AB	030AJV06XAA	030AJV06XAB
Cooling Performance¹				CONTINUED →
EER/SEER ²	12/15	12/15	12/15	12/15
Nominal CFM/AHRI Rated CFM [L/s]	1000/975 [472/460]	1000/975 [472/460]	1000/975 [472/460]	1000/975 [472/460]
AHRI Net Cooling Capacity Btu [kW]	28,600 [8.38]	28,600 [8.38]	28,600 [8.38]	28,600 [8.38]
Net Sensible Capacity Btu [kW]	21,200 [6.21]	21,200 [6.21]	21,200 [6.21]	21,200 [6.21]
Net Latent Capacity Btu [kW]	7,400 [2.17]	7,400 [2.17]	7,400 [2.17]	7,400 [2.17]
Net System Power kW	2.21	2.21	2.21	2.21
Heating Performance (Gas)³				
Heating Input Btu [kW]	60,000 [17.58]	60,000 [17.58]	60,000 [17.58]	60,000 [17.58]
Heating Output Btu [kW]	48,000 [14.06]	48,000 [14.06]	48,000 [14.06]	48,000 [14.06]
Temperature Rise Range °F [°C]	40-70 [22.2-38.9]	40-70 [22.2-38.9]	40-70 [22.2-38.9]	40-70 [22.2-38.9]
AFUE % ⁴	81	81	81	81
Steady State Efficiency (%)	82	82	82	82
No. Burners	3	3	3	3
No. Stages	1	1	1	1
Gas Connection Pipe Size in. [mm]	0.5 [12.7]	0.5 [12.7]	0.5 [12.7]	0.5 [12.7]
Compressor				
No./Type	1/Scroll	1/Scroll	1/Scroll	1/Scroll
Outdoor Sound Rating (dB)⁵	76	76	76	76
Outdoor Coil—Fin Type	Louvered	Louvered	Louvered	Louvered
Tube Type	MicroChannel	MicroChannel	MicroChannel	MicroChannel
MicroChannel Depth in. [mm]	0.71 [18]	0.71 [18]	0.71 [18]	0.71 [18]
Face Area sq. ft. [sq. m]	9.9 [0.92]	9.9 [0.92]	9.9 [0.92]	9.9 [0.92]
Rows / FPI [FPcm]	1 / 23 [9]	1 / 23 [9]	1 / 23 [9]	1 / 23 [9]
Indoor Coil—Fin Type	Louvered	Louvered	Louvered	Louvered
Tube Type	MicroChannel	MicroChannel	MicroChannel	MicroChannel
MicroChannel Depth in. [mm]	1 [25.4]	1 [25.4]	1 [25.4]	1 [25.4]
Face Area sq. ft. [sq. m]	3.6 [0.33]	3.6 [0.33]	3.6 [0.33]	3.6 [0.33]
Rows / FPI [FPcm]	1 / 17 [7]	1 / 17 [7]	1 / 17 [7]	1 / 17 [7]
Refrigerant Control	TX Valves	TX Valves	TX Valves	TX Valves
Drain Connection No./Size in. [mm]	1/0.75 [19.05]	1/0.75 [19.05]	1/0.75 [19.05]	1/0.75 [19.05]
Outdoor Fan—Type	Propeller	Propeller	Propeller	Propeller
No. Used/Diameter in. [mm]	1/22 [558.8]	1/22 [558.8]	1/22 [558.8]	1/22 [558.8]
Drive Type/No. Speeds	Direct/1	Direct/1	Direct/1	Direct/1
CFM [L/s]	2500 [1180]	2500 [1180]	2500 [1180]	2500 [1180]
No. Motors/HP	1 at 1/3 HP	1 at 1/3 HP	1 at 1/3 HP	1 at 1/3 HP
Motor RPM	1075	1075	1075	1075
Indoor Fan—Type	FC Centrifugal	FC Centrifugal	FC Centrifugal	FC Centrifugal
No. Used/Diameter in. [mm]	1/10x9 [254x229]	1/10x9 [254x229]	1/10x9 [254x229]	1/10x9 [254x229]
Drive Type	Direct	Direct	Direct	Direct
No. Speeds	Multiple	Multiple	Multiple	Multiple
No. Motors	1	1	1	1
Motor HP	1/2	1/2	1/2	1/2
Motor RPM	1050	1050	1050	1050
Motor Frame Size	48	48	48	48
Filter—Type	Field Supplied	Field Supplied	Field Supplied	Field Supplied
Furnished	No	No	No	No
(NO.) Size Recommended in. [mm x mm x mm]	(1)1x24x24 [25x610x610]	(1)1x24x24 [25x610x610]	(1)1x24x24 [25x610x610]	(1)1x24x24 [25x610x610]
Refrigerant Charge Oz. [g]	46.8 [1327]	46.8 [1327]	46.8 [1327]	46.8 [1327]
Weights				
Net Weight lbs. [kg]	403 [183]	403 [183]	403 [183]	403 [183]
Ship Weight lbs. [kg]	413 [187]	413 [187]	413 [187]	413 [187]

See Page 50 for Notes.

[] Designates Metric Conversions

NOMINAL SIZES 2-5 TONS [7.0-17.6 kW]

Model RGEA15 Series	030AJV081AA	030AJV081AB	030AJV08XAA	030AJV08XAB
Cooling Performance¹				CONTINUED →
EER/SEER ²	12/15	12/15	12/15	12/15
Nominal CFM/AHRI Rated CFM [L/s]	1000/975 [472/460]	1000/975 [472/460]	1000/975 [472/460]	1000/975 [472/460]
AHRI Net Cooling Capacity Btu [kW]	28,600 [8.38]	28,600 [8.38]	28,600 [8.38]	28,600 [8.38]
Net Sensible Capacity Btu [kW]	21,200 [6.21]	21,200 [6.21]	21,200 [6.21]	21,200 [6.21]
Net Latent Capacity Btu [kW]	7,400 [2.17]	7,400 [2.17]	7,400 [2.17]	7,400 [2.17]
Net System Power kW	2.21	2.21	2.21	2.21
Heating Performance (Gas)³				
Heating Input Btu [kW]	80,000 [23.44]	80,000 [23.44]	80,000 [23.44]	80,000 [23.44]
Heating Output Btu [kW]	65,000 [19.04]	65,000 [19.04]	65,000 [19.04]	65,000 [19.04]
Temperature Rise Range °F [°C]	35-65 [19.4-36.1]	35-65 [19.4-36.1]	35-65 [19.4-36.1]	35-65 [19.4-36.1]
AFUE % ⁴	81	81	81	81
Steady State Efficiency (%)	82	82	82	82
No. Burners	3	3	3	3
No. Stages	1	1	1	1
Gas Connection Pipe Size in. [mm]	0.5 [12.7]	0.5 [12.7]	0.5 [12.7]	0.5 [12.7]
Compressor				
No./Type	1/Scroll	1/Scroll	1/Scroll	1/Scroll
Outdoor Sound Rating (dB)⁵	76	76	76	76
Outdoor Coil—Fin Type	Louvered	Louvered	Louvered	Louvered
Tube Type	MicroChannel	MicroChannel	MicroChannel	MicroChannel
MicroChannel Depth in. [mm]	0.71 [18]	0.71 [18]	0.71 [18]	0.71 [18]
Face Area sq. ft. [sq. m]	9.9 [0.92]	9.9 [0.92]	9.9 [0.92]	9.9 [0.92]
Rows / FPI [FPcm]	1 / 23 [9]	1 / 23 [9]	1 / 23 [9]	1 / 23 [9]
Indoor Coil—Fin Type	Louvered	Louvered	Louvered	Louvered
Tube Type	MicroChannel	MicroChannel	MicroChannel	MicroChannel
MicroChannel Depth in. [mm]	1 [25.4]	1 [25.4]	1 [25.4]	1 [25.4]
Face Area sq. ft. [sq. m]	3.6 [0.33]	3.6 [0.33]	3.6 [0.33]	3.6 [0.33]
Rows / FPI [FPcm]	1 / 17 [7]	1 / 17 [7]	1 / 17 [7]	1 / 17 [7]
Refrigerant Control	TX Valves	TX Valves	TX Valves	TX Valves
Drain Connection No./Size in. [mm]	1/0.75 [19.05]	1/0.75 [19.05]	1/0.75 [19.05]	1/0.75 [19.05]
Outdoor Fan—Type	Propeller	Propeller	Propeller	Propeller
No. Used/Diameter in. [mm]	1/22 [558.8]	1/22 [558.8]	1/22 [558.8]	1/22 [558.8]
Drive Type/No. Speeds	Direct/1	Direct/1	Direct/1	Direct/1
CFM [L/s]	2500 [1180]	2500 [1180]	2500 [1180]	2500 [1180]
No. Motors/HP	1 at 1/3 HP	1 at 1/3 HP	1 at 1/3 HP	1 at 1/3 HP
Motor RPM	1075	1075	1075	1075
Indoor Fan—Type	FC Centrifugal	FC Centrifugal	FC Centrifugal	FC Centrifugal
No. Used/Diameter in. [mm]	1/10x9 [254x229]	1/10x9 [254x229]	1/10x9 [254x229]	1/10x9 [254x229]
Drive Type	Direct	Direct	Direct	Direct
No. Speeds	Multiple	Multiple	Multiple	Multiple
No. Motors	1	1	1	1
Motor HP	1/2	1/2	1/2	1/2
Motor RPM	1050	1050	1050	1050
Motor Frame Size	48	48	48	48
Filter—Type	Field Supplied	Field Supplied	Field Supplied	Field Supplied
Furnished	No	No	No	No
(NO.) Size Recommended in. [mm x mm x mm]	(1)1x24x24 [25x610x610]	(1)1x24x24 [25x610x610]	(1)1x24x24 [25x610x610]	(1)1x24x24 [25x610x610]
Refrigerant Charge Oz. [g]	46.8 [1327]	46.8 [1327]	46.8 [1327]	46.8 [1327]
Weights				
Net Weight lbs. [kg]	408 [185]	408 [185]	408 [185]	408 [185]
Ship Weight lbs. [kg]	418 [190]	418 [190]	418 [190]	418 [190]

See Page 50 for Notes.

[] Designates Metric Conversions

NOMINAL SIZES 2-5 TONS [7.0-17.6 kW]

Model RGEA15 Series	036ACT061AA	036ACT06XAA	036ACT081AA	036ACT08XAA
Cooling Performance¹				CONTINUED →
EER/SEER ²	12/15	12/15	12/15	12/15
Nominal CFM/AHRI Rated CFM [L/s]	1200/1200 [566/566]	1200/1200 [566/566]	1200/1200 [566/566]	1200/1200 [566/566]
AHRI Net Cooling Capacity Btu [kW]	34,000 [9.96]	34,000 [9.96]	34,000 [9.96]	34,000 [9.96]
Net Sensible Capacity Btu [kW]	24,670 [7.23]	24,670 [7.23]	24,670 [7.23]	24,670 [7.23]
Net Latent Capacity Btu [kW]	9,330 [2.73]	9,330 [2.73]	9,330 [2.73]	9,330 [2.73]
Net System Power kW	2.77	2.77	2.77	2.77
Heating Performance (Gas)³				
Heating Input Btu [kW]	60,000 [17.58]	60,000 [17.58]	80,000 [23.44]	80,000 [23.44]
Heating Output Btu [kW]	48,000 [14.06]	48,000 [14.06]	65,000 [19.04]	65,000 [19.04]
Temperature Rise Range °F [°C]	40-70 [22.2-38.9]	40-70 [22.2-38.9]	35-65 [19.4-36.1]	35-65 [19.4-36.1]
AFUE % ⁴	81	81	81	81
Steady State Efficiency (%)	82	82	82	82
No. Burners	3	3	3	3
No. Stages	1	1	1	1
Gas Connection Pipe Size in. [mm]	0.5 [12.7]	0.5 [12.7]	0.5 [12.7]	0.5 [12.7]
Compressor				
No./Type	1/Scroll	1/Scroll	1/Scroll	1/Scroll
Outdoor Sound Rating (dB)⁵				
	76	76	76	76
Outdoor Coil—Fin Type				
Tube Type	Louvered	Louvered	Louvered	Louvered
MicroChannel Depth in. [mm]	MicroChannel	MicroChannel	MicroChannel	MicroChannel
Face Area sq. ft. [sq. m]	0.71 [18]	0.71 [18]	0.71 [18]	0.71 [18]
Rows / FPI [FPcm]	9.8 [0.91]	9.8 [0.91]	9.8 [0.91]	9.8 [0.91]
	1 / 23 [9]	1 / 23 [9]	1 / 23 [9]	1 / 23 [9]
Indoor Coil—Fin Type				
Tube Type	Louvered	Louvered	Louvered	Louvered
MicroChannel Depth in. [mm]	MicroChannel	MicroChannel	MicroChannel	MicroChannel
Face Area sq. ft. [sq. m]	1 [25.4]	1 [25.4]	1 [25.4]	1 [25.4]
Rows / FPI [FPcm]	3.6 [0.33]	3.6 [0.33]	3.6 [0.33]	3.6 [0.33]
	1 / 17 [7]	1 / 17 [7]	1 / 17 [7]	1 / 17 [7]
Refrigerant Control	TX Valves	TX Valves	TX Valves	TX Valves
Drain Connection No./Size in. [mm]	1/0.75 [19.05]	1/0.75 [19.05]	1/0.75 [19.05]	1/0.75 [19.05]
Outdoor Fan—Type				
No. Used/Diameter in. [mm]	Propeller	Propeller	Propeller	Propeller
Drive Type/No. Speeds	1/22 [558.8]	1/22 [558.8]	1/22 [558.8]	1/22 [558.8]
CFM [L/s]	Direct/1	Direct/1	Direct/1	Direct/1
No. Motors/HP	2700 [1274]	2700 [1274]	2700 [1274]	2700 [1274]
Motor RPM	1 at 1/3 HP	1 at 1/3 HP	1 at 1/3 HP	1 at 1/3 HP
	1075	1075	1075	1075
Indoor Fan—Type				
No. Used/Diameter in. [mm]	FC Centrifugal	FC Centrifugal	FC Centrifugal	FC Centrifugal
Drive Type	1/12x9 [305x229]	1/12x9 [305x229]	1/12x9 [305x229]	1/12x9 [305x229]
No. Speeds	Direct	Direct	Direct	Direct
No. Motors	Multiple	Multiple	Multiple	Multiple
Motor HP	1	1	1	1
Motor RPM	1/2	1/2	1/2	1/2
Motor Frame Size	1075	1075	1075	1075
	48	48	48	48
Filter—Type				
Furnished	Field Supplied	Field Supplied	Field Supplied	Field Supplied
(NO.) Size Recommended in. [mm x mm x mm]	No	No	No	No
	(1)1x24x24 [25x610x610]	(1)1x24x24 [25x610x610]	(1)1x24x24 [25x610x610]	(1)1x24x24 [25x610x610]
Refrigerant Charge Oz. [g]				
	52.7 [1494]	52.7 [1494]	52.7 [1494]	52.7 [1494]
Weights				
Net Weight lbs. [kg]	411 [186]	411 [186]	416 [189]	416 [189]
Ship Weight lbs. [kg]	421 [191]	421 [191]	426 [193]	426 [193]

See Page 50 for Notes.

[] Designates Metric Conversions

NOMINAL SIZES 2-5 TONS [7.0-17.6 kW]

Model RGEA15 Series	036ACT101AA	036ACT10XAA	036ADT061AA	036ADT06XAA
Cooling Performance¹				CONTINUED →
EER/SEER ²	12/15	12/15	12/15	12/15
Nominal CFM/AHRI Rated CFM [L/s]	1200/1200 [566/566]	1200/1200 [566/566]	1200/1200 [566/566]	1200/1200 [566/566]
AHRI Net Cooling Capacity Btu [kW]	34,000 [9.96]	34,000 [9.96]	34,000 [9.96]	34,000 [9.96]
Net Sensible Capacity Btu [kW]	24,670 [7.23]	24,670 [7.23]	24,670 [7.23]	24,670 [7.23]
Net Latent Capacity Btu [kW]	9,330 [2.73]	9,330 [2.73]	9,330 [2.73]	9,330 [2.73]
Net System Power kW	2.77	2.77	2.77	2.77
Heating Performance (Gas)³				
Heating Input Btu [kW]	100,000 [29.3]	100,000 [29.3]	60,000 [17.58]	60,000 [17.58]
Heating Output Btu [kW]	81,000 [23.73]	81,000 [23.73]	48,000 [14.06]	48,000 [14.06]
Temperature Rise Range °F [°C]	45-75 [25-41.7]	45-75 [25-41.7]	40-70 [22.2-38.9]	40-70 [22.2-38.9]
AFUE % ⁴	81	81	81	81
Steady State Efficiency (%)	82	82	82	82
No. Burners	3	3	3	3
No. Stages	1	1	1	1
Gas Connection Pipe Size in. [mm]	0.5 [12.7]	0.5 [12.7]	0.5 [12.7]	0.5 [12.7]
Compressor				
No./Type	1/Scroll	1/Scroll	1/Scroll	1/Scroll
Outdoor Sound Rating (dB)⁵	76	76	76	76
Outdoor Coil—Fin Type	Louvered	Louvered	Louvered	Louvered
Tube Type	MicroChannel	MicroChannel	MicroChannel	MicroChannel
MicroChannel Depth in. [mm]	0.71 [18]	0.71 [18]	0.71 [18]	0.71 [18]
Face Area sq. ft. [sq. m]	9.8 [0.91]	9.8 [0.91]	9.8 [0.91]	9.8 [0.91]
Rows / FPI [FPcm]	1 / 23 [9]	1 / 23 [9]	1 / 23 [9]	1 / 23 [9]
Indoor Coil—Fin Type	Louvered	Louvered	Louvered	Louvered
Tube Type	MicroChannel	MicroChannel	MicroChannel	MicroChannel
MicroChannel Depth in. [mm]	1 [25.4]	1 [25.4]	1 [25.4]	1 [25.4]
Face Area sq. ft. [sq. m]	3.6 [0.33]	3.6 [0.33]	3.6 [0.33]	3.6 [0.33]
Rows / FPI [FPcm]	1 / 17 [7]	1 / 17 [7]	1 / 17 [7]	1 / 17 [7]
Refrigerant Control	TX Valves	TX Valves	TX Valves	TX Valves
Drain Connection No./Size in. [mm]	1/0.75 [19.05]	1/0.75 [19.05]	1/0.75 [19.05]	1/0.75 [19.05]
Outdoor Fan—Type	Propeller	Propeller	Propeller	Propeller
No. Used/Diameter in. [mm]	1/22 [558.8]	1/22 [558.8]	1/22 [558.8]	1/22 [558.8]
Drive Type/No. Speeds	Direct/1	Direct/1	Direct/1	Direct/1
CFM [L/s]	2700 [1274]	2700 [1274]	2700 [1274]	2700 [1274]
No. Motors/HP	1 at 1/3 HP	1 at 1/3 HP	1 at 1/3 HP	1 at 1/3 HP
Motor RPM	1075	1075	1075	1075
Indoor Fan—Type	FC Centrifugal	FC Centrifugal	FC Centrifugal	FC Centrifugal
No. Used/Diameter in. [mm]	1/12x9 [305x229]	1/12x9 [305x229]	1/12x9 [305x229]	1/12x9 [305x229]
Drive Type	Direct	Direct	Direct	Direct
No. Speeds	Multiple	Multiple	Multiple	Multiple
No. Motors	1	1	1	1
Motor HP	1/2	1/2	1/2	1/2
Motor RPM	1075	1075	1075	1075
Motor Frame Size	48	48	48	48
Filter—Type	Field Supplied	Field Supplied	Field Supplied	Field Supplied
Furnished	No	No	No	No
(NO.) Size Recommended in. [mm x mm x mm]	(1)1x24x24 [25x610x610]	(1)1x24x24 [25x610x610]	(1)1x24x24 [25x610x610]	(1)1x24x24 [25x610x610]
Refrigerant Charge Oz. [g]	52.7 [1494]	52.7 [1494]	52.7 [1494]	52.7 [1494]
Weights				
Net Weight lbs. [kg]	421 [191]	421 [191]	411 [186]	411 [186]
Ship Weight lbs. [kg]	431 [196]	431 [196]	421 [191]	421 [191]

See Page 50 for Notes.

[] Designates Metric Conversions

NOMINAL SIZES 2-5 TONS [7.0-17.6 kW]

Model RGEA15 Series	036ADT081AA	036ADT08XAA	036ADT101AA	036ADT10XAA
Cooling Performance¹				CONTINUED →
EER/SEER ²	12/15	12/15	12/15	12/15
Nominal CFM/AHRI Rated CFM [L/s]	1200/1200 [566/566]	1200/1200 [566/566]	1200/1200 [566/566]	1200/1200 [566/566]
AHRI Net Cooling Capacity Btu [kW]	34,000 [9.96]	34,000 [9.96]	34,000 [9.96]	34,000 [9.96]
Net Sensible Capacity Btu [kW]	24,670 [7.23]	24,670 [7.23]	24,670 [7.23]	24,670 [7.23]
Net Latent Capacity Btu [kW]	9,330 [2.73]	9,330 [2.73]	9,330 [2.73]	9,330 [2.73]
Net System Power kW	2.77	2.77	2.77	2.77
Heating Performance (Gas)³				
Heating Input Btu [kW]	80,000 [23.44]	80,000 [23.44]	100,000 [29.3]	100,000 [29.3]
Heating Output Btu [kW]	65,000 [19.04]	65,000 [19.04]	81,000 [23.73]	81,000 [23.73]
Temperature Rise Range °F [°C]	35-65 [19.4-36.1]	35-65 [19.4-36.1]	45-75 [25-41.7]	45-75 [25-41.7]
AFUE % ⁴	81	81	81	81
Steady State Efficiency (%)	82	82	82	82
No. Burners	3	3	3	3
No. Stages	1	1	1	1
Gas Connection Pipe Size in. [mm]	0.5 [12.7]	0.5 [12.7]	0.5 [12.7]	0.5 [12.7]
Compressor				
No./Type	1/Scroll	1/Scroll	1/Scroll	1/Scroll
Outdoor Sound Rating (dB)⁵				
	76	76	76	76
Outdoor Coil—Fin Type				
Tube Type	Louvered	Louvered	Louvered	Louvered
MicroChannel Depth in. [mm]	MicroChannel	MicroChannel	MicroChannel	MicroChannel
Face Area sq. ft. [sq. m]	0.71 [18]	0.71 [18]	0.71 [18]	0.71 [18]
Rows / FPI [FPcm]	9.8 [0.91]	9.8 [0.91]	9.8 [0.91]	9.8 [0.91]
	1 / 23 [9]	1 / 23 [9]	1 / 23 [9]	1 / 23 [9]
Indoor Coil—Fin Type				
Tube Type	Louvered	Louvered	Louvered	Louvered
MicroChannel Depth in. [mm]	MicroChannel	MicroChannel	MicroChannel	MicroChannel
Face Area sq. ft. [sq. m]	1 [25.4]	1 [25.4]	1 [25.4]	1 [25.4]
Rows / FPI [FPcm]	3.6 [0.33]	3.6 [0.33]	3.6 [0.33]	3.6 [0.33]
	1 / 17 [7]	1 / 17 [7]	1 / 17 [7]	1 / 17 [7]
Refrigerant Control	TX Valves	TX Valves	TX Valves	TX Valves
Drain Connection No./Size in. [mm]	1/0.75 [19.05]	1/0.75 [19.05]	1/0.75 [19.05]	1/0.75 [19.05]
Outdoor Fan—Type				
No. Used/Diameter in. [mm]	Propeller	Propeller	Propeller	Propeller
Drive Type/No. Speeds	1/22 [558.8]	1/22 [558.8]	1/22 [558.8]	1/22 [558.8]
CFM [L/s]	Direct/1	Direct/1	Direct/1	Direct/1
No. Motors/HP	2700 [1274]	2700 [1274]	2700 [1274]	2700 [1274]
Motor RPM	1 at 1/3 HP	1 at 1/3 HP	1 at 1/3 HP	1 at 1/3 HP
	1075	1075	1075	1075
Indoor Fan—Type				
No. Used/Diameter in. [mm]	FC Centrifugal	FC Centrifugal	FC Centrifugal	FC Centrifugal
Drive Type	1/12x9 [305x229]	1/12x9 [305x229]	1/12x9 [305x229]	1/12x9 [305x229]
No. Speeds	Direct	Direct	Direct	Direct
No. Motors	Multiple	Multiple	Multiple	Multiple
Motor HP	1	1	1	1
Motor RPM	1/2	1/2	1/2	1/2
Motor Frame Size	1075	1075	1075	1075
	48	48	48	48
Filter—Type				
Furnished	Field Supplied	Field Supplied	Field Supplied	Field Supplied
(NO.) Size Recommended in. [mm x mm x mm]	No	No	No	No
	(1)1x24x24 [25x610x610]	(1)1x24x24 [25x610x610]	(1)1x24x24 [25x610x610]	(1)1x24x24 [25x610x610]
Refrigerant Charge Oz. [g]				
	52.7 [1494]	52.7 [1494]	52.7 [1494]	52.7 [1494]
Weights				
Net Weight lbs. [kg]	416 [189]	416 [189]	421 [191]	421 [191]
Ship Weight lbs. [kg]	426 [193]	426 [193]	431 [196]	431 [196]

See Page 50 for Notes.

[] Designates Metric Conversions

NOMINAL SIZES 2-5 TONS [7.0-17.6 kW]

Model RGEA15 Series	036AJT061AA	036AJT06XAA	036AJT081AA	036AJT08XAA
Cooling Performance¹				CONTINUED →
EER/SEER ²	12/15	12/15	12/15	12/15
Nominal CFM/AHRI Rated CFM [L/s]	1200/1200 [566/566]	1200/1200 [566/566]	1200/1200 [566/566]	1200/1200 [566/566]
AHRI Net Cooling Capacity Btu [kW]	34,000 [9.96]	34,000 [9.96]	34,000 [9.96]	34,000 [9.96]
Net Sensible Capacity Btu [kW]	24,670 [7.23]	24,670 [7.23]	24,670 [7.23]	24,670 [7.23]
Net Latent Capacity Btu [kW]	9,330 [2.73]	9,330 [2.73]	9,330 [2.73]	9,330 [2.73]
Net System Power kW	2.77	2.77	2.77	2.77
Heating Performance (Gas)³				
Heating Input Btu [kW]	60,000 [17.58]	60,000 [17.58]	80,000 [23.44]	80,000 [23.44]
Heating Output Btu [kW]	48,000 [14.06]	48,000 [14.06]	65,000 [19.04]	65,000 [19.04]
Temperature Rise Range °F [°C]	40-70 [22.2-38.9]	40-70 [22.2-38.9]	35-65 [19.4-36.1]	35-65 [19.4-36.1]
AFUE % ⁴	81	81	81	81
Steady State Efficiency (%)	82	82	82	82
No. Burners	3	3	3	3
No. Stages	1	1	1	1
Gas Connection Pipe Size in. [mm]	0.5 [12.7]	0.5 [12.7]	0.5 [12.7]	0.5 [12.7]
Compressor				
No./Type	1/Scroll	1/Scroll	1/Scroll	1/Scroll
Outdoor Sound Rating (dB)⁵				
	76	76	76	76
Outdoor Coil—Fin Type				
Tube Type	Louvered	Louvered	Louvered	Louvered
MicroChannel Depth in. [mm]	MicroChannel	MicroChannel	MicroChannel	MicroChannel
Face Area sq. ft. [sq. m]	0.71 [18]	0.71 [18]	0.71 [18]	0.71 [18]
Rows / FPI [FPcm]	9.8 [0.91]	9.8 [0.91]	9.8 [0.91]	9.8 [0.91]
	1 / 23 [9]	1 / 23 [9]	1 / 23 [9]	1 / 23 [9]
Indoor Coil—Fin Type				
Tube Type	Louvered	Louvered	Louvered	Louvered
MicroChannel Depth in. [mm]	MicroChannel	MicroChannel	MicroChannel	MicroChannel
Face Area sq. ft. [sq. m]	1 [25.4]	1 [25.4]	1 [25.4]	1 [25.4]
Rows / FPI [FPcm]	3.6 [0.33]	3.6 [0.33]	3.6 [0.33]	3.6 [0.33]
	1 / 17 [7]	1 / 17 [7]	1 / 17 [7]	1 / 17 [7]
Refrigerant Control	TX Valves	TX Valves	TX Valves	TX Valves
Drain Connection No./Size in. [mm]	1/0.75 [19.05]	1/0.75 [19.05]	1/0.75 [19.05]	1/0.75 [19.05]
Outdoor Fan—Type				
No. Used/Diameter in. [mm]	Propeller	Propeller	Propeller	Propeller
Drive Type/No. Speeds	1/22 [558.8]	1/22 [558.8]	1/22 [558.8]	1/22 [558.8]
CFM [L/s]	Direct/1	Direct/1	Direct/1	Direct/1
No. Motors/HP	2700 [1274]	2700 [1274]	2700 [1274]	2700 [1274]
Motor RPM	1 at 1/3 HP	1 at 1/3 HP	1 at 1/3 HP	1 at 1/3 HP
	1075	1075	1075	1075
Indoor Fan—Type				
No. Used/Diameter in. [mm]	FC Centrifugal	FC Centrifugal	FC Centrifugal	FC Centrifugal
Drive Type	1/12x9 [305x229]	1/12x9 [305x229]	1/12x9 [305x229]	1/12x9 [305x229]
No. Speeds	Direct	Direct	Direct	Direct
No. Motors	Multiple	Multiple	Multiple	Multiple
Motor HP	1	1	1	1
Motor RPM	1/2	1/2	1/2	1/2
Motor Frame Size	1075	1075	1075	1075
	48	48	48	48
Filter—Type				
Furnished	Field Supplied	Field Supplied	Field Supplied	Field Supplied
(NO.) Size Recommended in. [mm x mm x mm]	No	No	No	No
	(1)1x24x24 [25x610x610]	(1)1x24x24 [25x610x610]	(1)1x24x24 [25x610x610]	(1)1x24x24 [25x610x610]
Refrigerant Charge Oz. [g]				
	52.7 [1494]	52.7 [1494]	52.7 [1494]	52.7 [1494]
Weights				
Net Weight lbs. [kg]	411 [186]	411 [186]	416 [189]	416 [189]
Ship Weight lbs. [kg]	421 [191]	421 [191]	426 [193]	426 [193]

See Page 50 for Notes.

[] Designates Metric Conversions

NOMINAL SIZES 2-5 TONS [7.0-17.6 kW]

Model RGEA15 Series	036AJT101AA	036AJT10XAA	036AJV061AA	036AJV061AB
Cooling Performance¹				CONTINUED →
EER/SEER ²	12/15	12/15	12/15	12/15
Nominal CFM/AHRI Rated CFM [L/s]	1200/1200 [566/566]	1200/1200 [566/566]	1200/1200 [566/566]	1200/1200 [566/566]
AHRI Net Cooling Capacity Btu [kW]	34,000 [9.96]	34,000 [9.96]	34,000 [9.96]	34,000 [9.96]
Net Sensible Capacity Btu [kW]	24,670 [7.23]	24,670 [7.23]	24,670 [7.23]	24,670 [7.23]
Net Latent Capacity Btu [kW]	9,330 [2.73]	9,330 [2.73]	9,330 [2.73]	9,330 [2.73]
Net System Power kW	2.77	2.77	2.77	2.77
Heating Performance (Gas)³				
Heating Input Btu [kW]	100,000 [29.3]	100,000 [29.3]	60,000 [17.58]	60,000 [17.58]
Heating Output Btu [kW]	81,000 [23.73]	81,000 [23.73]	48,000 [14.06]	48,000 [14.06]
Temperature Rise Range °F [°C]	45-75 [25-41.7]	45-75 [25-41.7]	40-70 [22.2-38.9]	40-70 [22.2-38.9]
AFUE % ⁴	81	81	81	81
Steady State Efficiency (%)	82	82	82	82
No. Burners	3	3	3	3
No. Stages	1	1	1	1
Gas Connection Pipe Size in. [mm]	0.5 [12.7]	0.5 [12.7]	0.5 [12.7]	0.5 [12.7]
Compressor				
No./Type	1/Scroll	1/Scroll	1/Scroll	1/Scroll
Outdoor Sound Rating (dB)⁵				
	76	76	76	76
Outdoor Coil—Fin Type				
Tube Type	Louvered	Louvered	Louvered	Louvered
MicroChannel Depth in. [mm]	MicroChannel	MicroChannel	MicroChannel	MicroChannel
Face Area sq. ft. [sq. m]	0.71 [18]	0.71 [18]	0.71 [18]	0.71 [18]
Rows / FPI [FPcm]	9.8 [0.91]	9.8 [0.91]	9.8 [0.91]	9.8 [0.91]
	1 / 23 [9]	1 / 23 [9]	1 / 23 [9]	1 / 23 [9]
Indoor Coil—Fin Type				
Tube Type	Louvered	Louvered	Louvered	Louvered
MicroChannel Depth in. [mm]	MicroChannel	MicroChannel	MicroChannel	MicroChannel
Face Area sq. ft. [sq. m]	1 [25.4]	1 [25.4]	1 [25.4]	1 [25.4]
Rows / FPI [FPcm]	3.6 [0.33]	3.6 [0.33]	3.6 [0.33]	3.6 [0.33]
	1 / 17 [7]	1 / 17 [7]	1 / 17 [7]	1 / 17 [7]
Refrigerant Control	TX Valves	TX Valves	TX Valves	TX Valves
Drain Connection No./Size in. [mm]	1/0.75 [19.05]	1/0.75 [19.05]	1/0.75 [19.05]	1/0.75 [19.05]
Outdoor Fan—Type				
No. Used/Diameter in. [mm]	Propeller	Propeller	Propeller	Propeller
Drive Type/No. Speeds	1/22 [558.8]	1/22 [558.8]	1/22 [558.8]	1/22 [558.8]
CFM [L/s]	Direct/1	Direct/1	Direct/1	Direct/1
No. Motors/HP	2700 [1274]	2700 [1274]	2700 [1274]	2700 [1274]
Motor RPM	1 at 1/3 HP	1 at 1/3 HP	1 at 1/3 HP	1 at 1/3 HP
	1075	1075	1075	1075
Indoor Fan—Type				
No. Used/Diameter in. [mm]	FC Centrifugal	FC Centrifugal	FC Centrifugal	FC Centrifugal
Drive Type	1/12x9 [305x229]	1/12x9 [305x229]	1/10x9 [254x229]	1/10x9 [254x229]
No. Speeds	Direct	Direct	Direct	Direct
No. Motors	Multiple	Multiple	Multiple	Multiple
Motor HP	1	1	1	1
Motor RPM	1/2	1/2	1/2	1/2
Motor Frame Size	1075	1075	1050	1050
	48	48	48	48
Filter—Type				
Furnished	Field Supplied	Field Supplied	Field Supplied	Field Supplied
(NO.) Size Recommended in. [mm x mm x mm]	No	No	No	No
	(1)1x24x24 [25x610x610]	(1)1x24x24 [25x610x610]	(1)1x24x24 [25x610x610]	(1)1x24x24 [25x610x610]
Refrigerant Charge Oz. [g]				
	52.7 [1494]	52.7 [1494]	52.7 [1494]	52.7 [1494]
Weights				
Net Weight lbs. [kg]	421 [191]	421 [191]	411 [186]	411 [186]
Ship Weight lbs. [kg]	431 [196]	431 [196]	421 [191]	421 [191]

See Page 50 for Notes.

[] Designates Metric Conversions

NOMINAL SIZES 2-5 TONS [7.0-17.6 kW]

Model RGEA15 Series	036AJV06XAA	036AJV06XAB	036AJV081AA	036AJV081AB
Cooling Performance¹				CONTINUED 
EER/SEER ²	12/15	12/15	12/15	12/15
Nominal CFM/AHRI Rated CFM [L/s]	1200/1200 [566/566]	1200/1200 [566/566]	1200/1200 [566/566]	1200/1200 [566/566]
AHRI Net Cooling Capacity Btu [kW]	34,000 [9.96]	34,000 [9.96]	34,000 [9.96]	34,000 [9.96]
Net Sensible Capacity Btu [kW]	24,670 [7.23]	24,670 [7.23]	24,670 [7.23]	24,670 [7.23]
Net Latent Capacity Btu [kW]	9,330 [2.73]	9,330 [2.73]	9,330 [2.73]	9,330 [2.73]
Net System Power kW	2.77	2.77	2.77	2.77
Heating Performance (Gas)³				
Heating Input Btu [kW]	60,000 [17.58]	60,000 [17.58]	80,000 [23.44]	80,000 [23.44]
Heating Output Btu [kW]	48,000 [14.06]	48,000 [14.06]	65,000 [19.04]	65,000 [19.04]
Temperature Rise Range °F [°C]	40-70 [22.2-38.9]	40-70 [22.2-38.9]	35-65 [19.4-36.1]	35-65 [19.4-36.1]
AFUE % ⁴	81	81	81	81
Steady State Efficiency (%)	82	82	82	82
No. Burners	3	3	3	3
No. Stages	1	1	1	1
Gas Connection Pipe Size in. [mm]	0.5 [12.7]	0.5 [12.7]	0.5 [12.7]	0.5 [12.7]
Compressor				
No./Type	1/Scroll	1/Scroll	1/Scroll	1/Scroll
Outdoor Sound Rating (dB)⁵	76	76	76	76
Outdoor Coil—Fin Type	Louvered	Louvered	Louvered	Louvered
Tube Type	MicroChannel	MicroChannel	MicroChannel	MicroChannel
MicroChannel Depth in. [mm]	0.71 [18]	0.71 [18]	0.71 [18]	0.71 [18]
Face Area sq. ft. [sq. m]	9.8 [0.91]	9.8 [0.91]	9.8 [0.91]	9.8 [0.91]
Rows / FPI [FPcm]	1 / 23 [9]	1 / 23 [9]	1 / 23 [9]	1 / 23 [9]
Indoor Coil—Fin Type	Louvered	Louvered	Louvered	Louvered
Tube Type	MicroChannel	MicroChannel	MicroChannel	MicroChannel
MicroChannel Depth in. [mm]	1 [25.4]	1 [25.4]	1 [25.4]	1 [25.4]
Face Area sq. ft. [sq. m]	3.6 [0.33]	3.6 [0.33]	3.6 [0.33]	3.6 [0.33]
Rows / FPI [FPcm]	1 / 17 [7]	1 / 17 [7]	1 / 17 [7]	1 / 17 [7]
Refrigerant Control	TX Valves	TX Valves	TX Valves	TX Valves
Drain Connection No./Size in. [mm]	1/0.75 [19.05]	1/0.75 [19.05]	1/0.75 [19.05]	1/0.75 [19.05]
Outdoor Fan—Type	Propeller	Propeller	Propeller	Propeller
No. Used/Diameter in. [mm]	1/22 [558.8]	1/22 [558.8]	1/22 [558.8]	1/22 [558.8]
Drive Type/No. Speeds	Direct/1	Direct/1	Direct/1	Direct/1
CFM [L/s]	2700 [1274]	2700 [1274]	2700 [1274]	2700 [1274]
No. Motors/HP	1 at 1/3 HP	1 at 1/3 HP	1 at 1/3 HP	1 at 1/3 HP
Motor RPM	1075	1075	1075	1075
Indoor Fan—Type	FC Centrifugal	FC Centrifugal	FC Centrifugal	FC Centrifugal
No. Used/Diameter in. [mm]	1/10x9 [254x229]	1/10x9 [254x229]	1/10x9 [254x229]	1/10x9 [254x229]
Drive Type	Direct	Direct	Direct	Direct
No. Speeds	Multiple	Multiple	Multiple	Multiple
No. Motors	1	1	1	1
Motor HP	1/2	1/2	3/4	3/4
Motor RPM	1050	1050	1050	1050
Motor Frame Size	48	48	48	48
Filter—Type	Field Supplied	Field Supplied	Field Supplied	Field Supplied
Furnished	No	No	No	No
(NO.) Size Recommended in. [mm x mm x mm]	(1)1x24x24 [25x610x610]	(1)1x24x24 [25x610x610]	(1)1x24x24 [25x610x610]	(1)1x24x24 [25x610x610]
Refrigerant Charge Oz. [g]	52.7 [1494]	52.7 [1494]	52.7 [1494]	52.7 [1494]
Weights				
Net Weight lbs. [kg]	411 [186]	411 [186]	416 [189]	416 [189]
Ship Weight lbs. [kg]	421 [191]	421 [191]	426 [193]	426 [193]

See Page 50 for Notes.

[] Designates Metric Conversions

NOMINAL SIZES 2-5 TONS [7.0-17.6 kW]

Model RGEA15 Series	036AJV08XAA	036AJV08XAB	036AJV101AA	036AJV101AB
Cooling Performance¹				CONTINUED →
EER/SEER ²	12/15	12/15	12/15	12/15
Nominal CFM/AHRI Rated CFM [L/s]	1200/1200 [566/566]	1200/1200 [566/566]	1200/1200 [566/566]	1200/1200 [566/566]
AHRI Net Cooling Capacity Btu [kW]	34,000 [9.96]	34,000 [9.96]	34,000 [9.96]	34,000 [9.96]
Net Sensible Capacity Btu [kW]	24,670 [7.23]	24,670 [7.23]	24,670 [7.23]	24,670 [7.23]
Net Latent Capacity Btu [kW]	9,330 [2.73]	9,330 [2.73]	9,330 [2.73]	9,330 [2.73]
Net System Power kW	2.77	2.77	2.77	2.77
Heating Performance (Gas)³				
Heating Input Btu [kW]	80,000 [23.44]	80,000 [23.44]	100,000 [29.3]	100,000 [29.3]
Heating Output Btu [kW]	65,000 [19.04]	65,000 [19.04]	81,000 [23.73]	81,000 [23.73]
Temperature Rise Range °F [°C]	35-65 [19.4-36.1]	35-65 [19.4-36.1]	45-75 [25-41.7]	45-75 [25-41.7]
AFUE % ⁴	81	81	81	81
Steady State Efficiency (%)	82	82	82	82
No. Burners	3	3	3	3
No. Stages	1	1	1	1
Gas Connection Pipe Size in. [mm]	0.5 [12.7]	0.5 [12.7]	0.5 [12.7]	0.5 [12.7]
Compressor				
No./Type	1/Scroll	1/Scroll	1/Scroll	1/Scroll
Outdoor Sound Rating (dB)⁵	76	76	76	76
Outdoor Coil—Fin Type	Louvered	Louvered	Louvered	Louvered
Tube Type	MicroChannel	MicroChannel	MicroChannel	MicroChannel
MicroChannel Depth in. [mm]	0.71 [18]	0.71 [18]	0.71 [18]	0.71 [18]
Face Area sq. ft. [sq. m]	9.8 [0.91]	9.8 [0.91]	9.8 [0.91]	9.8 [0.91]
Rows / FPI [FPcm]	1 / 23 [9]	1 / 23 [9]	1 / 23 [9]	1 / 23 [9]
Indoor Coil—Fin Type	Louvered	Louvered	Louvered	Louvered
Tube Type	MicroChannel	MicroChannel	MicroChannel	MicroChannel
MicroChannel Depth in. [mm]	1 [25.4]	1 [25.4]	1 [25.4]	1 [25.4]
Face Area sq. ft. [sq. m]	3.6 [0.33]	3.6 [0.33]	3.6 [0.33]	3.6 [0.33]
Rows / FPI [FPcm]	1 / 17 [7]	1 / 17 [7]	1 / 17 [7]	1 / 17 [7]
Refrigerant Control	TX Valves	TX Valves	TX Valves	TX Valves
Drain Connection No./Size in. [mm]	1/0.75 [19.05]	1/0.75 [19.05]	1/0.75 [19.05]	1/0.75 [19.05]
Outdoor Fan—Type	Propeller	Propeller	Propeller	Propeller
No. Used/Diameter in. [mm]	1/22 [558.8]	1/22 [558.8]	1/22 [558.8]	1/22 [558.8]
Drive Type/No. Speeds	Direct/1	Direct/1	Direct/1	Direct/1
CFM [L/s]	2700 [1274]	2700 [1274]	2700 [1274]	2700 [1274]
No. Motors/HP	1 at 1/3 HP	1 at 1/3 HP	1 at 1/3 HP	1 at 1/3 HP
Motor RPM	1075	1075	1075	1075
Indoor Fan—Type	FC Centrifugal	FC Centrifugal	FC Centrifugal	FC Centrifugal
No. Used/Diameter in. [mm]	1/10x9 [254x229]	1/10x9 [254x229]	1/10x9 [254x229]	1/10x9 [254x229]
Drive Type	Direct	Direct	Direct	Direct
No. Speeds	Multiple	Multiple	Multiple	Multiple
No. Motors	1	1	1	1
Motor HP	3/4	3/4	3/4	3/4
Motor RPM	1050	1050	1050	1050
Motor Frame Size	48	48	48	48
Filter—Type	Field Supplied	Field Supplied	Field Supplied	Field Supplied
Furnished	No	No	No	No
(NO.) Size Recommended in. [mm x mm x mm]	(1)1x24x24 [25x610x610]	(1)1x24x24 [25x610x610]	(1)1x24x24 [25x610x610]	(1)1x24x24 [25x610x610]
Refrigerant Charge Oz. [g]	52.7 [1494]	52.7 [1494]	52.7 [1494]	52.7 [1494]
Weights				
Net Weight lbs. [kg]	416 [189]	416 [189]	421 [191]	421 [191]
Ship Weight lbs. [kg]	426 [193]	426 [193]	431 [196]	431 [196]

See Page 50 for Notes.

[] Designates Metric Conversions

NOMINAL SIZES 2-5 TONS [7.0-17.6 kW]

Model RGEA15 Series	036AJV10XAA	036AJV10XAB	042ACT081AA	042ACT08XAA
Cooling Performance¹				CONTINUED →
EER/SEER ²	12/15	12/15	12/15	12/15
Nominal CFM/AHRI Rated CFM [L/s]	1200/1200 [566/566]	1200/1200 [566/566]	1400/1300 [661/613]	1400/1300 [661/613]
AHRI Net Cooling Capacity Btu [kW]	34,000 [9.96]	34,000 [9.96]	39,500 [11.58]	39,500 [11.58]
Net Sensible Capacity Btu [kW]	24,670 [7.23]	24,670 [7.23]	28,240 [8.28]	28,240 [8.28]
Net Latent Capacity Btu [kW]	9,330 [2.73]	9,330 [2.73]	11,260 [3.30]	11,260 [3.30]
Net System Power kW	2.77	2.77	3.28	3.28
Heating Performance (Gas)³				
Heating Input Btu [kW]	100,000 [29.3]	100,000 [29.3]	80,000 [23.44]	80,000 [23.44]
Heating Output Btu [kW]	81,000 [23.73]	81,000 [23.73]	65,000 [19.04]	65,000 [19.04]
Temperature Rise Range °F [°C]	45-75 [25-41.7]	45-75 [25-41.7]	35-65 [19.4-36.1]	35-65 [19.4-36.1]
AFUE % ⁴	81	81	81	81
Steady State Efficiency (%)	82	82	82	82
No. Burners	3	3	4	4
No. Stages	1	1	1	1
Gas Connection Pipe Size in. [mm]	0.5 [12.7]	0.5 [12.7]	0.5 [12.7]	0.5 [12.7]
Compressor				
No./Type	1/Scroll	1/Scroll	1/Scroll	1/Scroll
Outdoor Sound Rating (dB)⁵				
	76	76	76	76
Outdoor Coil—Fin Type				
Tube Type	Louvered	Louvered	Louvered	Louvered
MicroChannel Depth in. [mm]	MicroChannel	MicroChannel	MicroChannel	MicroChannel
Face Area sq. ft. [sq. m]	0.71 [18]	0.71 [18]	0.71 [18]	0.71 [18]
Rows / FPI [FPcm]	9.8 [0.91]	9.8 [0.91]	14.1 [1.31]	14.1 [1.31]
	1 / 23 [9]	1 / 23 [9]	1 / 23 [9]	1 / 23 [9]
Indoor Coil—Fin Type				
Tube Type	Louvered	Louvered	Louvered	Louvered
MicroChannel Depth in. [mm]	MicroChannel	MicroChannel	MicroChannel	MicroChannel
Face Area sq. ft. [sq. m]	1 [25.4]	1 [25.4]	1 [25.4]	1 [25.4]
Rows / FPI [FPcm]	3.6 [0.33]	3.6 [0.33]	3.6 [0.33]	3.6 [0.33]
	1 / 17 [7]	1 / 17 [7]	1 / 17 [7]	1 / 17 [7]
Refrigerant Control	TX Valves	TX Valves	TX Valves	TX Valves
Drain Connection No./Size in. [mm]	1/0.75 [19.05]	1/0.75 [19.05]	1/0.75 [19.05]	1/0.75 [19.05]
Outdoor Fan—Type				
No. Used/Diameter in. [mm]	Propeller	Propeller	Propeller	Propeller
Drive Type/No. Speeds	1/22 [558.8]	1/22 [558.8]	1/22 [558.8]	1/22 [558.8]
CFM [L/s]	Direct/1	Direct/1	Direct/1	Direct/1
No. Motors/HP	2700 [1274]	2700 [1274]	3500 [1652]	3500 [1652]
Motor RPM	1 at 1/3 HP	1 at 1/3 HP	1 at 1/3 HP	1 at 1/3 HP
	1075	1075	1075	1075
Indoor Fan—Type				
No. Used/Diameter in. [mm]	FC Centrifugal	FC Centrifugal	FC Centrifugal	FC Centrifugal
Drive Type	1/10x9 [254x229]	1/10x9 [254x229]	1/12x9 [305x229]	1/12x9 [305x229]
No. Speeds	Direct	Direct	Direct	Direct
No. Motors	Multiple	Multiple	Multiple	Multiple
Motor HP	1	1	1	1
Motor RPM	3/4	3/4	3/4	3/4
Motor Frame Size	1050	1050	1075	1075
	48	48	48	48
Filter—Type				
Furnished	Field Supplied	Field Supplied	Field Supplied	Field Supplied
(NO.) Size Recommended in. [mm x mm x mm]	No	No	No	No
	(1)1x24x24 [25x610x610]	(1)1x24x24 [25x610x610]	(1)1x24x24 [25x610x610]	(1)1x24x24 [25x610x610]
Refrigerant Charge Oz. [g]				
	52.7 [1494]	52.7 [1494]	61.3 [1738]	61.3 [1738]
Weights				
Net Weight lbs. [kg]	421 [191]	421 [191]	445 [202]	445 [202]
Ship Weight lbs. [kg]	431 [196]	431 [196]	455 [206]	455 [206]

See Page 50 for Notes.

[] Designates Metric Conversions

NOMINAL SIZES 2-5 TONS [7.0-17.6 kW]

Model RGEA15 Series	042ACT101AA	042ACT10XAA	042AJV081AA	042AJV081AB
Cooling Performance¹				CONTINUED →
EER/SEER ²	12/15	12/15	12/15	12/15
Nominal CFM/AHRI Rated CFM [L/s]	1400/1300 [661/613]	1400/1300 [661/613]	1400/1300 [661/613]	1400/1300 [661/613]
AHRI Net Cooling Capacity Btu [kW]	39,500 [11.58]	39,500 [11.58]	39,500 [11.58]	39,500 [11.58]
Net Sensible Capacity Btu [kW]	28,240 [8.28]	28,240 [8.28]	28,240 [8.28]	28,240 [8.28]
Net Latent Capacity Btu [kW]	11,260 [3.30]	11,260 [3.30]	11,260 [3.30]	11,260 [3.30]
Net System Power kW	3.28	3.28	3.28	3.28
Heating Performance (Gas)³				
Heating Input Btu [kW]	100,000 [29.3]	100,000 [29.3]	80,000 [23.44]	80,000 [23.44]
Heating Output Btu [kW]	81,000 [23.73]	81,000 [23.73]	65,000 [19.04]	65,000 [19.04]
Temperature Rise Range °F [°C]	45-75 [25-41.7]	45-75 [25-41.7]	35-65 [19.4-36.1]	35-65 [19.4-36.1]
AFUE % ⁴	81	81	81	81
Steady State Efficiency (%)	82	82	82	82
No. Burners	4	4	4	4
No. Stages	1	1	1	1
Gas Connection Pipe Size in. [mm]	0.5 [12.7]	0.5 [12.7]	0.5 [12.7]	0.5 [12.7]
Compressor				
No./Type	1/Scroll	1/Scroll	1/Scroll	1/Scroll
Outdoor Sound Rating (dB)⁵				
	76	76	76	76
Outdoor Coil—Fin Type				
Tube Type	Louvered	Louvered	Louvered	Louvered
MicroChannel Depth in. [mm]	MicroChannel	MicroChannel	MicroChannel	MicroChannel
Face Area sq. ft. [sq. m]	0.71 [18]	0.71 [18]	0.71 [18]	0.71 [18]
Rows / FPI [FPcm]	14.1 [1.31]	14.1 [1.31]	14.1 [1.31]	14.1 [1.31]
	1 / 23 [9]	1 / 23 [9]	1 / 23 [9]	1 / 23 [9]
Indoor Coil—Fin Type				
Tube Type	Louvered	Louvered	Louvered	Louvered
MicroChannel Depth in. [mm]	MicroChannel	MicroChannel	MicroChannel	MicroChannel
Face Area sq. ft. [sq. m]	1 [25.4]	1 [25.4]	1 [25.4]	1 [25.4]
Rows / FPI [FPcm]	3.6 [0.33]	3.6 [0.33]	3.6 [0.33]	3.6 [0.33]
	1 / 17 [7]	1 / 17 [7]	1 / 17 [7]	1 / 17 [7]
Refrigerant Control	TX Valves	TX Valves	TX Valves	TX Valves
Drain Connection No./Size in. [mm]	1/0.75 [19.05]	1/0.75 [19.05]	1/0.75 [19.05]	1/0.75 [19.05]
Outdoor Fan—Type				
No. Used/Diameter in. [mm]	Propeller	Propeller	Propeller	Propeller
Drive Type/No. Speeds	1/22 [558.8]	1/22 [558.8]	1/22 [558.8]	1/22 [558.8]
CFM [L/s]	Direct/1	Direct/1	Direct/1	Direct/1
No. Motors/HP	3500 [1652]	3500 [1652]	3500 [1652]	3500 [1652]
Motor RPM	1 at 1/3 HP	1 at 1/3 HP	1 at 1/3 HP	1 at 1/3 HP
	1075	1075	1075	1075
Indoor Fan—Type				
No. Used/Diameter in. [mm]	FC Centrifugal	FC Centrifugal	FC Centrifugal	FC Centrifugal
Drive Type	1/12x9 [305x229]	1/12x9 [305x229]	1/10x9 [254x229]	1/10x9 [254x229]
No. Speeds	Direct	Direct	Direct	Direct
No. Motors	Multiple	Multiple	Multiple	Multiple
Motor HP	1	1	1	1
Motor RPM	3/4	3/4	3/4	3/4
Motor Frame Size	1075	1075	1050	1050
	48	48	48	48
Filter—Type				
Furnished	Field Supplied	Field Supplied	Field Supplied	Field Supplied
(NO.) Size Recommended in. [mm x mm x mm]	No	No	No	No
	(1)1x24x24 [25x610x610]	(1)1x24x24 [25x610x610]	(1)1x24x24 [25x610x610]	(1)1x24x24 [25x610x610]
Refrigerant Charge Oz. [g]				
	61.3 [1738]	61.3 [1738]	61.3 [1738]	61.3 [1738]
Weights				
Net Weight lbs. [kg]	450 [204]	450 [204]	445 [202]	445 [202]
Ship Weight lbs. [kg]	460 [209]	460 [209]	455 [206]	455 [206]

See Page 50 for Notes.

[] Designates Metric Conversions

NOMINAL SIZES 2-5 TONS [7.0-17.6 kW]

Model RGEA15 Series	042AJV08XAA	042AJV08XAB	042AJV101AA	042AJV101AB
Cooling Performance¹				CONTINUED →
EER/SEER ²	12/15	12/15	12/15	12/15
Nominal CFM/AHRI Rated CFM [L/s]	1400/1300 [661/613]	1400/1300 [661/613]	1400/1300 [661/613]	1400/1300 [661/613]
AHRI Net Cooling Capacity Btu [kW]	39,500 [11.58]	39,500 [11.58]	39,500 [11.58]	39,500 [11.58]
Net Sensible Capacity Btu [kW]	28,240 [8.28]	28,240 [8.28]	28,240 [8.28]	28,240 [8.28]
Net Latent Capacity Btu [kW]	11,260 [3.30]	11,260 [3.30]	11,260 [3.30]	11,260 [3.30]
Net System Power kW	3.28	3.28	3.28	3.28
Heating Performance (Gas)³				
Heating Input Btu [kW]	80,000 [23.44]	80,000 [23.44]	100,000 [29.3]	100,000 [29.3]
Heating Output Btu [kW]	65,000 [19.04]	65,000 [19.04]	81,000 [23.73]	81,000 [23.73]
Temperature Rise Range °F [°C]	35-65 [19.4-36.1]	35-65 [19.4-36.1]	45-75 [25-41.7]	45-75 [25-41.7]
AFUE % ⁴	81	81	81	81
Steady State Efficiency (%)	82	82	82	82
No. Burners	4	4	4	4
No. Stages	1	1	1	1
Gas Connection Pipe Size in. [mm]	0.5 [12.7]	0.5 [12.7]	0.5 [12.7]	0.5 [12.7]
Compressor				
No./Type	1/Scroll	1/Scroll	1/Scroll	1/Scroll
Outdoor Sound Rating (dB)⁵	76	76	76	76
Outdoor Coil—Fin Type	Louvered	Louvered	Louvered	Louvered
Tube Type	MicroChannel	MicroChannel	MicroChannel	MicroChannel
MicroChannel Depth in. [mm]	0.71 [18]	0.71 [18]	0.71 [18]	0.71 [18]
Face Area sq. ft. [sq. m]	14.1 [1.31]	14.1 [1.31]	14.1 [1.31]	14.1 [1.31]
Rows / FPI [FPcm]	1 / 23 [9]	1 / 23 [9]	1 / 23 [9]	1 / 23 [9]
Indoor Coil—Fin Type	Louvered	Louvered	Louvered	Louvered
Tube Type	MicroChannel	MicroChannel	MicroChannel	MicroChannel
MicroChannel Depth in. [mm]	1 [25.4]	1 [25.4]	1 [25.4]	1 [25.4]
Face Area sq. ft. [sq. m]	3.6 [0.33]	3.6 [0.33]	3.6 [0.33]	3.6 [0.33]
Rows / FPI [FPcm]	1 / 17 [7]	1 / 17 [7]	1 / 17 [7]	1 / 17 [7]
Refrigerant Control	TX Valves	TX Valves	TX Valves	TX Valves
Drain Connection No./Size in. [mm]	1/0.75 [19.05]	1/0.75 [19.05]	1/0.75 [19.05]	1/0.75 [19.05]
Outdoor Fan—Type	Propeller	Propeller	Propeller	Propeller
No. Used/Diameter in. [mm]	1/22 [558.8]	1/22 [558.8]	1/22 [558.8]	1/22 [558.8]
Drive Type/No. Speeds	Direct/1	Direct/1	Direct/1	Direct/1
CFM [L/s]	3500 [1652]	3500 [1652]	3500 [1652]	3500 [1652]
No. Motors/HP	1 at 1/3 HP	1 at 1/3 HP	1 at 1/3 HP	1 at 1/3 HP
Motor RPM	1075	1075	1075	1075
Indoor Fan—Type	FC Centrifugal	FC Centrifugal	FC Centrifugal	FC Centrifugal
No. Used/Diameter in. [mm]	1/10x9 [254x229]	1/10x9 [254x229]	1/10x9 [254x229]	1/10x9 [254x229]
Drive Type	Direct	Direct	Direct	Direct
No. Speeds	Multiple	Multiple	Multiple	Multiple
No. Motors	1	1	1	1
Motor HP	3/4	3/4	3/4	3/4
Motor RPM	1050	1050	1050	1050
Motor Frame Size	48	48	48	48
Filter—Type	Field Supplied	Field Supplied	Field Supplied	Field Supplied
Furnished	No	No	No	No
(NO.) Size Recommended in. [mm x mm x mm]	(1)1x24x24 [25x610x610]	(1)1x24x24 [25x610x610]	(1)1x24x24 [25x610x610]	(1)1x24x24 [25x610x610]
Refrigerant Charge Oz. [g]	61.3 [1738]	61.3 [1738]	61.3 [1738]	61.3 [1738]
Weights				
Net Weight lbs. [kg]	445 [202]	445 [202]	450 [204]	450 [204]
Ship Weight lbs. [kg]	455 [206]	455 [206]	460 [209]	460 [209]

See Page 50 for Notes.

[] Designates Metric Conversions

NOMINAL SIZES 2-5 TONS [7.0-17.6 kW]

Model RGEA15 Series	042AJV10XAA	042AJV10XAB	048ACT081AA	048ACT08XAA
Cooling Performance¹				CONTINUED →
EER/SEER ²	12/15	12/15	12/14.7	12/14.7
Nominal CFM/AHRI Rated CFM [L/s]	1400/1300 [661/613]	1400/1300 [661/613]	1600/1550 [755/731]	1600/1550 [755/731]
AHRI Net Cooling Capacity Btu [kW]	39,500 [11.58]	39,500 [11.58]	45,000 [13.19]	45,000 [13.19]
Net Sensible Capacity Btu [kW]	28,240 [8.28]	28,240 [8.28]	32,280 [9.46]	32,280 [9.46]
Net Latent Capacity Btu [kW]	11,260 [3.30]	11,260 [3.30]	12,720 [3.73]	12,720 [3.73]
Net System Power kW	3.28	3.28	3.66	3.66
Heating Performance (Gas)³				
Heating Input Btu [kW]	100,000 [29.3]	100,000 [29.3]	80,000 [23.44]	80,000 [23.44]
Heating Output Btu [kW]	81,000 [23.73]	81,000 [23.73]	65,000 [19.04]	65,000 [19.04]
Temperature Rise Range °F [°C]	45-75 [25-41.7]	45-75 [25-41.7]	35-65 [19.4-36.1]	35-65 [19.4-36.1]
AFUE % ⁴	81	81	81	81
Steady State Efficiency (%)	82	82	82	82
No. Burners	4	4	4	4
No. Stages	1	1	1	1
Gas Connection Pipe Size in. [mm]	0.5 [12.7]	0.5 [12.7]	0.5 [12.7]	0.5 [12.7]
Compressor				
No./Type	1/Scroll	1/Scroll	1/Scroll	1/Scroll
Outdoor Sound Rating (dB)⁵	76	76	78	78
Outdoor Coil—Fin Type	Louvered	Louvered	Louvered	Louvered
Tube Type	MicroChannel	MicroChannel	MicroChannel	MicroChannel
MicroChannel Depth in. [mm]	0.71 [18]	0.71 [18]	0.71 [18]	0.71 [18]
Face Area sq. ft. [sq. m]	14.1 [1.31]	14.1 [1.31]	16.3 [1.51]	16.3 [1.51]
Rows / FPI [FPcm]	1 / 23 [9]	1 / 23 [9]	1 / 23 [9]	1 / 23 [9]
Indoor Coil—Fin Type	Louvered	Louvered	Louvered	Louvered
Tube Type	MicroChannel	MicroChannel	MicroChannel	MicroChannel
MicroChannel Depth in. [mm]	1 [25.4]	1 [25.4]	1.26 [32]	1.26 [32]
Face Area sq. ft. [sq. m]	3.6 [0.33]	3.6 [0.33]	4.1 [0.38]	4.1 [0.38]
Rows / FPI [FPcm]	1 / 17 [7]	1 / 17 [7]	1 / 20 [8]	1 / 20 [8]
Refrigerant Control	TX Valves	TX Valves	TX Valves	TX Valves
Drain Connection No./Size in. [mm]	1/0.75 [19.05]	1/0.75 [19.05]	1/0.75 [19.05]	1/0.75 [19.05]
Outdoor Fan—Type	Propeller	Propeller	Propeller	Propeller
No. Used/Diameter in. [mm]	1/22 [558.8]	1/22 [558.8]	1/22 [558.8]	1/22 [558.8]
Drive Type/No. Speeds	Direct/1	Direct/1	Direct/1	Direct/1
CFM [L/s]	3500 [1652]	3500 [1652]	3300 [1557]	3300 [1557]
No. Motors/HP	1 at 1/3 HP	1 at 1/3 HP	1 at 1/3 HP	1 at 1/3 HP
Motor RPM	1075	1075	1075	1075
Indoor Fan—Type	FC Centrifugal	FC Centrifugal	FC Centrifugal	FC Centrifugal
No. Used/Diameter in. [mm]	1/10x9 [254x229]	1/10x9 [254x229]	1/12x9 [305x229]	1/12x9 [305x229]
Drive Type	Direct	Direct	Direct	Direct
No. Speeds	Multiple	Multiple	Multiple	Multiple
No. Motors	1	1	1	1
Motor HP	3/4	3/4	3/4	3/4
Motor RPM	1050	1050	1075	1075
Motor Frame Size	48	48	48	48
Filter—Type	Field Supplied	Field Supplied	Field Supplied	Field Supplied
Furnished	No	No	No	No
(NO.) Size Recommended in. [mm x mm x mm]	(1)1x24x24 [25x610x610]	(1)1x24x24 [25x610x610]	(1)1x24x24 [25x610x610]	(1)1x24x24 [25x610x610]
Refrigerant Charge Oz. [g]	61.3 [1738]	61.3 [1738]	85.3 [2418]	85.3 [2418]
Weights				
Net Weight lbs. [kg]	450 [204]	450 [204]	492 [223]	492 [223]
Ship Weight lbs. [kg]	460 [209]	460 [209]	502 [228]	502 [228]

See Page 50 for Notes.

[] Designates Metric Conversions

NOMINAL SIZES 2-5 TONS [7.0-17.6 kW]

Model RGEA15 Series	048ACT101AA	048ACT10XAA	048ADT101AA	048ADT10XAA
Cooling Performance¹				CONTINUED 
EER/SEER ²	12/14.7	12/14.7	12/14.7	12/14.7
Nominal CFM/AHRI Rated CFM [L/s]	1600/1550 [755/731]	1600/1550 [755/731]	1600/1550 [755/731]	1600/1550 [755/731]
AHRI Net Cooling Capacity Btu [kW]	45,000 [13.19]	45,000 [13.19]	45,000 [13.19]	45,000 [13.19]
Net Sensible Capacity Btu [kW]	32,280 [9.46]	32,280 [9.46]	32,280 [9.46]	32,280 [9.46]
Net Latent Capacity Btu [kW]	12,720 [3.73]	12,720 [3.73]	12,720 [3.73]	12,720 [3.73]
Net System Power kW	3.66	3.66	3.66	3.66
Heating Performance (Gas)³				
Heating Input Btu [kW]	100,000 [29.3]	100,000 [29.3]	100,000 [29.3]	100,000 [29.3]
Heating Output Btu [kW]	81,000 [23.73]	81,000 [23.73]	81,000 [23.73]	81,000 [23.73]
Temperature Rise Range °F [°C]	45-75 [25-41.7]	45-75 [25-41.7]	45-75 [25-41.7]	45-75 [25-41.7]
AFUE % ⁴	81	81	81	81
Steady State Efficiency (%)	82	82	82	82
No. Burners	4	4	4	4
No. Stages	1	1	1	1
Gas Connection Pipe Size in. [mm]	0.5 [12.7]	0.5 [12.7]	0.5 [12.7]	0.5 [12.7]
Compressor				
No./Type	1/Scroll	1/Scroll	1/Scroll	1/Scroll
Outdoor Sound Rating (dB)⁵	78	78	78	78
Outdoor Coil—Fin Type	Louvered	Louvered	Louvered	Louvered
Tube Type	MicroChannel	MicroChannel	MicroChannel	MicroChannel
MicroChannel Depth in. [mm]	0.71 [18]	0.71 [18]	0.7 [17.8]	0.7 [17.8]
Face Area sq. ft. [sq. m]	16.3 [1.51]	16.3 [1.51]	16.3 [1.51]	16.3 [1.51]
Rows / FPI [FPcm]	1 / 23 [9]	1 / 23 [9]	1 / 23 [9]	1 / 23 [9]
Indoor Coil—Fin Type	Louvered	Louvered	Louvered	Louvered
Tube Type	MicroChannel	MicroChannel	MicroChannel	MicroChannel
MicroChannel Depth in. [mm]	1.26 [32]	1.26 [32]	1.26 [32]	1.26 [32]
Face Area sq. ft. [sq. m]	4.1 [0.38]	4.1 [0.38]	4.1 [0.38]	4.1 [0.38]
Rows / FPI [FPcm]	1 / 20 [8]	1 / 20 [8]	1 / 20 [8]	1 / 20 [8]
Refrigerant Control	TX Valves	TX Valves	TX Valves	TX Valves
Drain Connection No./Size in. [mm]	1/0.75 [19.05]	1/0.75 [19.05]	1/0.75 [19.05]	1/0.75 [19.05]
Outdoor Fan—Type	Propeller	Propeller	Propeller	Propeller
No. Used/Diameter in. [mm]	1/22 [558.8]	1/22 [558.8]	1/22 [558.8]	1/22 [558.8]
Drive Type/No. Speeds	Direct/1	Direct/1	Direct/1	Direct/1
CFM [L/s]	3300 [1557]	3300 [1557]	3300 [1557]	3300 [1557]
No. Motors/HP	1 at 1/3 HP	1 at 1/3 HP	1 at 1/3 HP	1 at 1/3 HP
Motor RPM	1075	1075	1075	1075
Indoor Fan—Type	FC Centrifugal	FC Centrifugal	FC Centrifugal	FC Centrifugal
No. Used/Diameter in. [mm]	1/12x9 [305x229]	1/12x9 [305x229]	1/12x9 [305x229]	1/12x9 [305x229]
Drive Type	Direct	Direct	Direct	Direct
No. Speeds	Multiple	Multiple	Multiple	Multiple
No. Motors	1	1	1	1
Motor HP	3/4	3/4	3/4	3/4
Motor RPM	1075	1075	1075	1075
Motor Frame Size	48	48	48	48
Filter—Type	Field Supplied	Field Supplied	Field Supplied	Field Supplied
Furnished	No	No	No	No
(NO.) Size Recommended in. [mm x mm x mm]	(1)1x24x24 [25x610x610]	(1)1x24x24 [25x610x610]	(1)1x24x24 [25x610x610]	(1)1x24x24 [25x610x610]
Refrigerant Charge Oz. [g]	85.3 [2418]	85.3 [2418]	85.3 [2418]	85.3 [2418]
Weights				
Net Weight lbs. [kg]	497 [225]	497 [225]	497 [225]	497 [225]
Ship Weight lbs. [kg]	507 [230]	507 [230]	507 [230]	507 [230]

See Page 50 for Notes.

[] Designates Metric Conversions

NOMINAL SIZES 2-5 TONS [7.0-17.6 kW]

Model RGEA15 Series	048AJT10XAA	048AJV081AA	048AJV081AB	048AJV08XAA
Cooling Performance¹				CONTINUED →
EER/SEER ²	12/14.7	12/14.7	12/14.7	12/14.7
Nominal CFM/AHRI Rated CFM [L/s]	1600/1550 [755/731]	1600/1550 [755/731]	1600/1550 [755/731]	1600/1550 [755/731]
AHRI Net Cooling Capacity Btu [kW]	45,000 [13.19]	45,000 [13.19]	45,000 [13.19]	45,000 [13.19]
Net Sensible Capacity Btu [kW]	32,280 [9.46]	32,280 [9.46]	32,280 [9.46]	32,280 [9.46]
Net Latent Capacity Btu [kW]	12,720 [3.73]	12,720 [3.73]	12,720 [3.73]	12,720 [3.73]
Net System Power kW	3.66	3.66	3.66	3.66
Heating Performance (Gas)³				
Heating Input Btu [kW]	100,000 [29.3]	80,000 [23.44]	80,000 [23.44]	80,000 [23.44]
Heating Output Btu [kW]	81,000 [23.73]	65,000 [19.04]	65,000 [19.04]	65,000 [19.04]
Temperature Rise Range °F [°C]	45-75 [25-41.7]	35-65 [19.4-36.1]	35-65 [19.4-36.1]	35-65 [19.4-36.1]
AFUE % ⁴	81	81	81	81
Steady State Efficiency (%)	82	82	82	82
No. Burners	4	4	4	4
No. Stages	1	1	1	1
Gas Connection Pipe Size in. [mm]	0.5 [12.7]	0.5 [12.7]	0.5 [12.7]	0.5 [12.7]
Compressor				
No./Type	1/Scroll	1/Scroll	1/Scroll	1/Scroll
Outdoor Sound Rating (dB)⁵	78	78	78	78
Outdoor Coil—Fin Type	Louvered	Louvered	Louvered	Louvered
Tube Type	MicroChannel	MicroChannel	MicroChannel	MicroChannel
MicroChannel Depth in. [mm]	0.7 [17.8]	0.7 [17.8]	0.7 [17.8]	0.7 [17.8]
Face Area sq. ft. [sq. m]	16.3 [1.51]	16.3 [1.51]	16.3 [1.51]	16.3 [1.51]
Rows / FPI [FPcm]	1 / 23 [9]	1 / 23 [9]	1 / 23 [9]	1 / 23 [9]
Indoor Coil—Fin Type	Louvered	Louvered	Louvered	Louvered
Tube Type	MicroChannel	MicroChannel	MicroChannel	MicroChannel
MicroChannel Depth in. [mm]	1.26 [32]	1.26 [32]	1.26 [32]	1.26 [32]
Face Area sq. ft. [sq. m]	4.1 [0.38]	4.1 [0.38]	4.1 [0.38]	4.1 [0.38]
Rows / FPI [FPcm]	1 / 20 [8]	1 / 20 [8]	1 / 20 [8]	1 / 20 [8]
Refrigerant Control	TX Valves	TX Valves	TX Valves	TX Valves
Drain Connection No./Size in. [mm]	1/0.75 [19.05]	1/0.75 [19.05]	1/0.75 [19.05]	1/0.75 [19.05]
Outdoor Fan—Type	Propeller	Propeller	Propeller	Propeller
No. Used/Diameter in. [mm]	1/22 [558.8]	1/22 [558.8]	1/22 [558.8]	1/22 [558.8]
Drive Type/No. Speeds	Direct/1	Direct/1	Direct/1	Direct/1
CFM [L/s]	3300 [1557]	3300 [1557]	3300 [1557]	3300 [1557]
No. Motors/HP	1 at 1/3 HP	1 at 1/3 HP	1 at 1/3 HP	1 at 1/3 HP
Motor RPM	1075	1075	1075	1075
Indoor Fan—Type	FC Centrifugal	FC Centrifugal	FC Centrifugal	FC Centrifugal
No. Used/Diameter in. [mm]	1/12x9 [305x229]	1/12x9 [305x229]	1/12x9 [305x229]	1/12x9 [305x229]
Drive Type	Direct	Direct	Direct	Direct
No. Speeds	Multiple	Multiple	Multiple	Multiple
No. Motors	1	1	1	1
Motor HP	3/4	1	1	1
Motor RPM	1075	1050	1050	1050
Motor Frame Size	48	48	48	48
Filter—Type	Field Supplied	Field Supplied	Field Supplied	Field Supplied
Furnished	No	No	No	No
(NO.) Size Recommended in. [mm x mm x mm]	(1)1x24x24 [25x610x610]	(1)1x24x24 [25x610x610]	(1)1x24x24 [25x610x610]	(1)1x24x24 [25x610x610]
Refrigerant Charge Oz. [g]	85.3 [2418]	85.3 [2418]	85.3 [2418]	85.3 [2418]
Weights				
Net Weight lbs. [kg]	497 [225]	492 [223]	492 [223]	492 [223]
Ship Weight lbs. [kg]	507 [230]	502 [228]	502 [228]	502 [228]

See Page 50 for Notes.

[] Designates Metric Conversions

NOMINAL SIZES 2-5 TONS [7.0-17.6 kW]

Model RGEA15 Series	048AJV08XAB	048AJV101AA	048AJV101AB	048AJV10XAA
Cooling Performance¹				CONTINUED →
EER/SEER ²	12/14.7	12/14.7	12/14.7	12/14.7
Nominal CFM/AHRI Rated CFM [L/s]	1600/1550 [755/731]	1600/1550 [755/731]	1600/1550 [755/731]	1600/1550 [755/731]
AHRI Net Cooling Capacity Btu [kW]	45,000 [13.19]	45,000 [13.19]	45,000 [13.19]	45,000 [13.19]
Net Sensible Capacity Btu [kW]	32,280 [9.46]	32,280 [9.46]	32,280 [9.46]	32,280 [9.46]
Net Latent Capacity Btu [kW]	12,720 [3.73]	12,720 [3.73]	12,720 [3.73]	12,720 [3.73]
Net System Power kW	3.66	3.66	3.66	3.66
Heating Performance (Gas)³				
Heating Input Btu [kW]	80,000 [23.44]	100,000 [29.3]	100,000 [29.3]	100,000 [29.3]
Heating Output Btu [kW]	65,000 [19.04]	81,000 [23.73]	81,000 [23.73]	81,000 [23.73]
Temperature Rise Range °F [°C]	35-65 [19.4-36.1]	45-75 [25-41.7]	45-75 [25-41.7]	45-75 [25-41.7]
AFUE % ⁴	81	81	81	81
Steady State Efficiency (%)	82	82	82	82
No. Burners	4	4	4	4
No. Stages	1	1	1	1
Gas Connection Pipe Size in. [mm]	0.5 [12.7]	0.5 [12.7]	0.5 [12.7]	0.5 [12.7]
Compressor				
No./Type	1/Scroll	1/Scroll	1/Scroll	1/Scroll
Outdoor Sound Rating (dB)⁵	78	78	78	78
Outdoor Coil—Fin Type	Louvered	Louvered	Louvered	Louvered
Tube Type	MicroChannel	MicroChannel	MicroChannel	MicroChannel
MicroChannel Depth in. [mm]	0.7 [17.8]	0.7 [17.8]	0.7 [17.8]	0.7 [17.8]
Face Area sq. ft. [sq. m]	16.3 [1.51]	16.3 [1.51]	16.3 [1.51]	16.3 [1.51]
Rows / FPI [FPcm]	1 / 23 [9]	1 / 23 [9]	1 / 23 [9]	1 / 23 [9]
Indoor Coil—Fin Type	Louvered	Louvered	Louvered	Louvered
Tube Type	MicroChannel	MicroChannel	MicroChannel	MicroChannel
MicroChannel Depth in. [mm]	1.26 [32]	1.26 [32]	1.26 [32]	1.26 [32]
Face Area sq. ft. [sq. m]	4.1 [0.38]	4.1 [0.38]	4.1 [0.38]	4.1 [0.38]
Rows / FPI [FPcm]	1 / 20 [8]	1 / 20 [8]	1 / 20 [8]	1 / 20 [8]
Refrigerant Control	TX Valves	TX Valves	TX Valves	TX Valves
Drain Connection No./Size in. [mm]	1/0.75 [19.05]	1/0.75 [19.05]	1/0.75 [19.05]	1/0.75 [19.05]
Outdoor Fan—Type	Propeller	Propeller	Propeller	Propeller
No. Used/Diameter in. [mm]	1/22 [558.8]	1/22 [558.8]	1/22 [558.8]	1/22 [558.8]
Drive Type/No. Speeds	Direct/1	Direct/1	Direct/1	Direct/1
CFM [L/s]	3300 [1557]	3300 [1557]	3300 [1557]	3300 [1557]
No. Motors/HP	1 at 1/3 HP	1 at 1/3 HP	1 at 1/3 HP	1 at 1/3 HP
Motor RPM	1075	1075	1075	1075
Indoor Fan—Type	FC Centrifugal	FC Centrifugal	FC Centrifugal	FC Centrifugal
No. Used/Diameter in. [mm]	1/12x9 [305x229]	1/12x9 [305x229]	1/12x9 [305x229]	1/12x9 [305x229]
Drive Type	Direct	Direct	Direct	Direct
No. Speeds	Multiple	Multiple	Multiple	Multiple
No. Motors	1	1	1	1
Motor HP	1	1	1	1
Motor RPM	1050	1050	1050	1050
Motor Frame Size	48	48	48	48
Filter—Type	Field Supplied	Field Supplied	Field Supplied	Field Supplied
Furnished	No	No	No	No
(NO.) Size Recommended in. [mm x mm x mm]	(1)1x24x24 [25x610x610]	(1)1x24x24 [25x610x610]	(1)1x24x24 [25x610x610]	(1)1x24x24 [25x610x610]
Refrigerant Charge Oz. [g]	85.3 [2418]	85.3 [2418]	85.3 [2418]	85.3 [2418]
Weights				
Net Weight lbs. [kg]	492 [223]	497 [225]	497 [225]	497 [225]
Ship Weight lbs. [kg]	502 [228]	507 [230]	507 [230]	507 [230]

See Page 50 for Notes.

[] Designates Metric Conversions

NOMINAL SIZES 2-5 TONS [7.0-17.6 kW]

Model RGEA15 Series	048AJV10XAB
Cooling Performance¹	
EER/SEER ²	12/14.7
Nominal CFM/AHRI Rated CFM [L/s]	1600/1550 [755/731]
AHRI Net Cooling Capacity Btu [kW]	45,000 [13.19]
Net Sensible Capacity Btu [kW]	32,280 [9.46]
Net Latent Capacity Btu [kW]	12,720 [3.73]
Net System Power kW	3.66
Heating Performance (Gas)³	
Heating Input Btu [kW]	100,000 [29.3]
Heating Output Btu [kW]	81,000 [23.73]
Temperature Rise Range °F [°C]	45-75 [25-41.7]
AFUE % ⁴	81
Steady State Efficiency (%)	82
No. Burners	4
No. Stages	1
Gas Connection Pipe Size in. [mm]	0.5 [12.7]
Compressor	
No./Type	1/Scroll
Outdoor Sound Rating (dB)⁵	
78	
Outdoor Coil—Fin Type	
Louvered	
Tube Type	MicroChannel
MicroChannel Depth in. [mm]	0.7 [17.8]
Face Area sq. ft. [sq. m]	16.3 [1.51]
Rows / FPI [FPcm]	1 / 23 [9]
Indoor Coil—Fin Type	
Louvered	
Tube Type	MicroChannel
MicroChannel Depth in. [mm]	1.26 [32]
Face Area sq. ft. [sq. m]	4.1 [0.38]
Rows / FPI [FPcm]	1 / 20 [8]
Refrigerant Control	TX Valves
Drain Connection No./Size in. [mm]	1/0.75 [19.05]
Outdoor Fan—Type	
Propeller	
No. Used/Diameter in. [mm]	1/22 [558.8]
Drive Type/No. Speeds	Direct/1
CFM [L/s]	3300 [1557]
No. Motors/HP	1 at 1/3 HP
Motor RPM	1075
Indoor Fan—Type	
FC Centrifugal	
No. Used/Diameter in. [mm]	1/12x9 [305x229]
Drive Type	Direct
No. Speeds	Multiple
No. Motors	1
Motor HP	1
Motor RPM	1050
Motor Frame Size	48
Filter—Type	
Field Supplied	
Furnished	No
(NO.) Size Recommended in. [mm x mm x mm]	(1)1x24x24 [25x610x610]
Refrigerant Charge Oz. [g]	
85.3 [2418]	
Weights	
Net Weight lbs. [kg]	497 [225]
Ship Weight lbs. [kg]	507 [230]

CONTINUED →

See Page 50 for Notes.

[] Designates Metric Conversions



NOMINAL SIZES 2-5 TONS [7.0-17.6 kW]

Model RGEA15 Series	060ACT101AA	060ADT101AA	060ADT10XAA	060AJT101AA
Cooling Performance¹				CONTINUED →
EER/SEER ²	14.5	14.5	14.5	14.5
Nominal CFM/AHRI Rated CFM [L/s]	11	11	11	11
AHRI Net Cooling Capacity Btu [kW]	1250/1850 [590/873]	1250/1850 [590/873]	1250/1850 [590/873]	1250/1850 [590/873]
Net Sensible Capacity Btu [kW]	55,000 [16.12]	55,000 [16.12]	55,000 [16.12]	55,000 [16.12]
Net Latent Capacity Btu [kW]	39,270 [11.51]	39,270 [11.51]	39,270 [11.51]	39,270 [11.51]
Net System Power kW	15,730 [4.61]	15,730 [4.61]	15,730 [4.61]	15,730 [4.61]
Heating Performance (Gas)³	2.14/5.02	2.14/5.02	2.14/5.02	2.14/5.02
Heating Input Btu [kW]				
Heating Output Btu [kW]	100,000 [29.3]	100,000 [29.3]	100,000 [29.3]	100,000 [29.3]
Temperature Rise Range °F [°C]	81,000 [23.73]	81,000 [23.73]	81,000 [23.73]	81,000 [23.73]
AFUE % ⁴	45-75 [25-41.7]	45-75 [25-41.7]	45-75 [25-41.7]	45-75 [25-41.7]
Steady State Efficiency (%)	81	81	81	81
No. Burners	82	82	82	82
No. Stages	5	5	5	5
Gas Connection Pipe Size in. [mm]	1	1	1	1
Compressor	0.5 [12.7]	0.5 [12.7]	0.5 [12.7]	0.5 [12.7]
No./Type	1/Scroll	1/Scroll	1/Scroll	1/Scroll
Outdoor Sound Rating (dB)⁵	78	78	78	78
Outdoor Coil—Fin Type	Louvered	Louvered	Louvered	Louvered
Tube Type	MicroChannel	MicroChannel	MicroChannel	MicroChannel
MicroChannel Depth in. [mm]	1 [25.4]	1 [25.4]	1 [25.4]	1 [25.4]
Face Area sq. ft. [sq. m]	15.3 [1.42]	15.3 [1.42]	15.3 [1.42]	15.3 [1.42]
Rows / FPI [FPcm]	1 / 23 [9]	1 / 23 [9]	1 / 23 [9]	1 / 23 [9]
Indoor Coil—Fin Type	Louvered	Louvered	Louvered	Louvered
Tube Type	MicroChannel	MicroChannel	MicroChannel	MicroChannel
MicroChannel Depth in. [mm]	1.26 [32]	1.26 [32]	1.26 [32]	1.26 [32]
Face Area sq. ft. [sq. m]	4 [0.37]	4 [0.37]	4 [0.37]	4 [0.37]
Rows / FPI [FPcm]	1 / 20 [8]	1 / 20 [8]	1 / 20 [8]	1 / 20 [8]
Refrigerant Control	TX Valves	TX Valves	TX Valves	TX Valves
Drain Connection No./Size in. [mm]	1/0.75 [19.05]	1/0.75 [19.05]	1/0.75 [19.05]	1/0.75 [19.05]
Outdoor Fan—Type	Propeller	Propeller	Propeller	Propeller
No. Used/Diameter in. [mm]	1/22 [558.8]	1/22 [558.8]	1/22 [558.8]	1/22 [558.8]
Drive Type/No. Speeds	Direct/1	Direct/1	Direct/1	Direct/1
CFM [L/s]	3300 [1557]	3300 [1557]	3300 [1557]	3300 [1557]
No. Motors/HP	1 at 1/3 HP	1 at 1/3 HP	1 at 1/3 HP	1 at 1/3 HP
Motor RPM	1075	1075	1075	1075
Indoor Fan—Type	FC Centrifugal	FC Centrifugal	FC Centrifugal	FC Centrifugal
No. Used/Diameter in. [mm]	1/12x9 [305x229]	1/12x9 [305x229]	1/12x9 [305x229]	1/12x9 [305x229]
Drive Type	Direct	Direct	Direct	Direct
No. Speeds	Multiple	Multiple	Multiple	Multiple
No. Motors	1	1	1	1
Motor HP	1	1	1	1
Motor RPM	1075	1075	1075	1075
Motor Frame Size	48	48	48	48
Filter—Type	Field Supplied	Field Supplied	Field Supplied	Field Supplied
Furnished	No	No	No	No
(NO.) Size Recommended in. [mm x mm x mm]	(1)1x24x30 [25x610x762]	(1)1x24x30 [25x610x762]	(1)1x24x30 [25x610x762]	(1)1x24x30 [25x610x762]
Refrigerant Charge Oz. [g]	89.6 [2540]	89.6 [2540]	89.6 [2540]	89.6 [2540]
Weights				
Net Weight lbs. [kg]	515 [234]	515 [234]	515 [234]	515 [234]
Ship Weight lbs. [kg]	525 [238]	525 [238]	525 [238]	525 [238]

See Page 50 for Notes.

[] Designates Metric Conversions

NOMINAL SIZES 2-5 TONS [7.0-17.6 kW]

Model RGEA15 Series	060AJT10XAA	060AJV101AB	060AJV10XAB
Cooling Performance¹			
EER/SEER ²	14.5	14.5	14.5
Nominal CFM/AHRI Rated CFM [L/s]	11	11	11
AHRI Net Cooling Capacity Btu [kW]	1250/1850 [590/873]	1250/1850 [590/873]	1250/1850 [590/873]
Net Sensible Capacity Btu [kW]	55,000 [16.12]	55,000 [16.12]	55,000 [16.12]
Net Latent Capacity Btu [kW]	39,270 [11.51]	39,270 [11.51]	39,270 [11.51]
Net System Power kW	15,730 [4.61]	15,730 [4.61]	15,730 [4.61]
Heating Performance (Gas)³			
Heating Input Btu [kW]	2.14/5.02	2.14/5.02	2.14/5.02
Heating Output Btu [kW]	100,000 [29.3]	100,000 [29.3]	100,000 [29.3]
Temperature Rise Range °F [°C]	81,000 [23.73]	81,000 [23.73]	81,000 [23.73]
AFUE % ⁴	45-75 [25-41.7]	45-75 [25-41.7]	45-75 [25-41.7]
Steady State Efficiency (%)	81	81	81
No. Burners	82	82	82
No. Stages	5	5	5
Gas Connection Pipe Size in. [mm]	1	1	1
Compressor			
No./Type	0.5 [12.7]	0.5 [12.7]	0.5 [12.7]
	1/Scroll	1/Scroll	1/Scroll
Outdoor Sound Rating (dB)⁵			
	78	78	78
Outdoor Coil—Fin Type			
Tube Type	Louvered	Louvered	Louvered
MicroChannel Depth in. [mm]	MicroChannel	MicroChannel	MicroChannel
Face Area sq. ft. [sq. m]	1 [25.4]	1 [25.4]	1 [25.4]
Rows / FPI [FPcm]	15.3 [1.42]	15.3 [1.42]	15.3 [1.42]
	1 / 23 [9]	1 / 23 [9]	1 / 23 [9]
Indoor Coil—Fin Type			
Tube Type	Louvered	Louvered	Louvered
MicroChannel Depth in. [mm]	MicroChannel	MicroChannel	MicroChannel
Face Area sq. ft. [sq. m]	1.26 [32]	1.26 [32]	1.26 [32]
Rows / FPI [FPcm]	4 [0.37]	4 [0.37]	4 [0.37]
Refrigerant Control	1 / 20 [8]	1 / 20 [8]	1 / 20 [8]
Drain Connection No./Size in. [mm]	TX Valves	TX Valves	TX Valves
	1/0.75 [19.05]	1/0.75 [19.05]	1/0.75 [19.05]
Outdoor Fan—Type			
No. Used/Diameter in. [mm]	Propeller	Propeller	Propeller
Drive Type/No. Speeds	1/22 [558.8]	1/22 [558.8]	1/22 [558.8]
CFM [L/s]	Direct/1	Direct/1	Direct/1
No. Motors/HP	3300 [1557]	3300 [1557]	3300 [1557]
Motor RPM	1 at 1/3 HP	1 at 1/3 HP	1 at 1/3 HP
	1075	1075	1075
Indoor Fan—Type			
No. Used/Diameter in. [mm]	FC Centrifugal	FC Centrifugal	FC Centrifugal
Drive Type	1/12x9 [305x229]	1/12x9 [305x229]	1/12x9 [305x229]
No. Speeds	Direct	Direct	Direct
No. Motors	Multiple	Multiple	Multiple
Motor HP	1	1	1
Motor RPM	1	1	1
Motor Frame Size	1075	1050	1050
	48	48	48
Filter—Type			
Furnished	Field Supplied	Field Supplied	Field Supplied
(NO.) Size Recommended in. [mm x mm x mm]	No	No	No
	(1)1x24x30 [25x610x762]	(1)1x24x30 [25x610x762]	(1)1x24x30 [25x610x762]
Refrigerant Charge Oz. [g]			
	89.6 [2540]	89.6 [2540]	89.6 [2540]
Weights			
Net Weight lbs. [kg]	515 [234]	515 [234]	515 [234]
Ship Weight lbs. [kg]	525 [238]	525 [238]	525 [238]

See Page 50 for Notes.

[] Designates Metric Conversions



NOTES:

1. Cooling Performance is rated at 95° F ambient, 80° F entering dry bulb, 67° F entering wet bulb. Gross capacity does not include the effect of fan motor heat. AHRI capacity is net and includes the effect of fan motor heat. Units are suitable for operation in CFM range shown in airflow tables. Units are certified in accordance with the Unitary Air Conditioner Equipment certification program, which is based on AHRI Standard 210/240 or 360.
2. EER and/or SEER are rated at AHRI conditions and in accordance with DOE test procedures.
3. Heating Performance limit settings and rating data were established and approved under laboratory test conditions using American National Standard Institute standards. Ratings shown are for elevations up to 2000 feet. For elevations above 2000 feet, ratings should be reduced at the rate of 4% for each 1000 feet above sea level.
4. AFUE is rated in accordance with DOE test procedures.
5. Outdoor Sound Rating shown is tested in accordance with AHRI Standard 270.



GROSS SYSTEMS PERFORMANCE DATA – RGEA14024A

wbE		ENTERING INDOOR AIR @ 80°F [26.7°C] dbE ①									
		71°F [21.7°C]			67°F [19.4°C]			63°F [17.2°C]			
		CFM [L/s]	990 [467]	900 [425]	760 [359]	990 [467]	900 [425]	760 [359]	990 [467]	900 [425]	760 [359]
DR ①		0.21	0.19	0.15	0.21	0.19	0.15	0.21	0.19	0.15	
OUTDOOR DRY BULB TEMPERATURE °F [°C]	75 [23.9]	Total BTUH [kW] Sens BTUH [kW] Power	30.9 [9.1] 18.7 [5.5] 1.4	30.4 [8.9] 17.9 [5.2] 1.4	29.5 [8.7] 16.6 [4.9] 1.4	29.1 [8.5] 21.9 [6.4] 1.4	28.6 [8.4] 20.9 [6.1] 1.4	27.8 [8.1] 19.4 [5.7] 1.4	27.5 [8.1] 24.6 [7.2] 1.4	27.0 [7.9] 23.5 [6.9] 1.4	26.2 [7.7] 21.8 [6.4] 1.4
	80 [26.7]	Total BTUH [kW] Sens BTUH [kW] Power	30.0 [8.8] 18.2 [5.3] 1.5	29.4 [8.6] 17.4 [5.1] 1.5	28.6 [8.4] 16.1 [4.7] 1.5	28.1 [8.2] 21.4 [6.3] 1.5	27.6 [8.1] 20.4 [6.0] 1.5	26.8 [7.9] 18.9 [5.5] 1.5	26.5 [7.8] 24.0 [7.0] 1.5	26.0 [7.6] 23.0 [6.7] 1.5	25.3 [7.4] 21.3 [6.2] 1.5
	85 [29.4]	Total BTUH [kW] Sens BTUH [kW] Power	29.0 [8.5] 17.6 [5.2] 1.6	28.5 [8.3] 16.8 [4.9] 1.6	27.7 [8.1] 15.6 [4.6] 1.6	27.1 [8.0] 20.8 [6.1] 1.6	26.7 [7.8] 19.9 [5.8] 1.6	25.9 [7.6] 18.4 [5.4] 1.6	25.5 [7.5] 23.5 [6.9] 1.6	25.1 [7.3] 22.4 [6.6] 1.6	24.4 [7.1] 20.8 [6.1] 1.6
	90 [32.2]	Total BTUH [kW] Sens BTUH [kW] Power	28.0 [8.2] 17.0 [5.0] 1.7	27.5 [8.1] 16.3 [4.8] 1.7	26.7 [7.8] 15.1 [4.4] 1.7	26.1 [7.7] 20.2 [5.9] 1.7	25.7 [7.5] 19.3 [5.7] 1.7	25.0 [7.3] 17.9 [5.3] 1.7	24.5 [7.2] 22.9 [6.7] 1.7	24.1 [7.1] 21.9 [6.4] 1.7	23.4 [6.9] 20.3 [5.9] 1.7
	95 [35]	Total BTUH [kW] Sens BTUH [kW] Power	27.0 [7.9] 16.5 [4.8] 1.9	26.5 [7.8] 15.7 [4.6] 1.8	25.7 [7.5] 14.6 [4.3] 1.8	25.1 [7.4] 19.7 [5.8] 1.8	24.7 [7.2] 18.8 [5.5] 1.8	24.0 [7.0] 17.4 [5.1] 1.8	23.5 [6.9] 22.3 [6.5] 1.8	23.1 [6.8] 21.3 [6.2] 1.8	22.4 [6.6] 19.8 [5.8] 1.8
	100 [37.8]	Total BTUH [kW] Sens BTUH [kW] Power	25.9 [7.6] 15.9 [4.6] 2.0	25.5 [7.5] 15.2 [4.4] 2.0	24.8 [7.3] 14.1 [4.1] 1.9	24.1 [7.1] 19.1 [5.6] 2.0	23.7 [6.9] 18.2 [5.3] 2.0	23.0 [6.7] 16.9 [5.0] 1.9	22.5 [6.6] 21.7 [6.4] 2.0	22.1 [6.5] 20.8 [6.1] 1.9	21.5 [6.3] 19.2 [5.6] 1.9
	105 [40.6]	Total BTUH [kW] Sens BTUH [kW] Power	24.9 [7.3] 15.3 [4.5] 2.1	24.5 [7.2] 14.6 [4.3] 2.1	23.8 [7.0] 13.5 [4.0] 2.1	23.1 [6.8] 18.5 [5.4] 2.1	22.6 [6.6] 17.7 [5.2] 2.1	22.0 [6.4] 16.4 [4.8] 2.1	21.4 [6.3] 21.1 [6.2] 2.1	21.1 [6.2] 20.2 [5.9] 2.1	20.5 [6.0] 18.7 [5.5] 2.0
	110 [43.3]	Total BTUH [kW] Sens BTUH [kW] Power	23.8 [7.0] 14.7 [4.3] 2.3	23.4 [6.9] 14.0 [4.1] 2.2	22.7 [6.7] 13.0 [3.8] 2.2	22.0 [6.4] 17.9 [5.2] 2.2	21.6 [6.3] 17.1 [5.0] 2.2	21.0 [6.1] 15.8 [4.6] 2.2	20.4 [6.0] 20.4 [6.0] 2.2	20.0 [5.9] 19.6 [5.7] 2.2	19.4 [5.7] 18.2 [5.3] 2.2
	115 [46.1]	Total BTUH [kW] Sens BTUH [kW] Power	22.8 [6.7] 14.1 [4.1] 2.4	22.3 [6.5] 13.4 [3.9] 2.4	21.7 [6.4] 12.5 [3.6] 2.3	20.9 [6.1] 17.3 [5.1] 2.4	20.5 [6.0] 16.5 [4.8] 2.4	19.9 [5.8] 15.3 [4.5] 2.3	19.3 [5.7] 19.3 [5.7] 2.4	18.9 [5.6] 18.9 [5.6] 2.4	18.4 [5.4] 17.6 [5.2] 2.3
	120 [48.9]	Total BTUH [kW] Sens BTUH [kW] Power	21.7 [6.3] 13.4 [3.9] 2.6	21.3 [6.2] 12.8 [3.8] 2.5	20.7 [6.1] 11.9 [3.5] 2.5	19.8 [5.8] 16.6 [4.9] 2.5	19.5 [5.7] 15.9 [4.7] 2.5	18.9 [5.5] 14.7 [4.3] 2.5	18.2 [5.3] 18.2 [5.3] 2.5	17.9 [5.2] 17.9 [5.2] 2.5	17.4 [5.1] 17.1 [5.0] 2.5
125 [51.7]	Total BTUH [kW] Sens BTUH [kW] Power	20.5 [6.0] 12.8 [3.8] 2.7	20.2 [5.9] 12.2 [3.6] 2.7	19.6 [5.7] 11.3 [3.3] 2.7	18.7 [5.5] 16.0 [4.7] 2.7	18.4 [5.4] 15.3 [4.5] 2.7	17.8 [5.2] 14.2 [4.2] 2.7	17.1 [5.0] 17.1 [5.0] 2.7	16.8 [4.9] 16.8 [4.9] 2.7	16.3 [4.8] 16.3 [4.8] 2.6	

DR —Depression ratio
dbE —Entering air dry bulb
wbE—Entering air wet bulb

Total —Total capacity x 1000 BTUH
Sens —Sensible capacity x 1000 BTUH
Power —KW input

NOTES: ① When the entering air dry bulb is other than 80°F [27°C], adjust the sensible capacity from the table by adding [1.10 x CFM x (1 – DR) x (dbE – 80)].

[] Designates Metric Conversions





GROSS SYSTEMS PERFORMANCE DATA—RGEA14030A

		ENTERING INDOOR AIR @ 80°F [26.7°C] dbE ①									
wbE		71°F [21.7°C]			67°F [19.4°C]			63°F [17.2°C]			
CFM [L/s]		1070 [505]	975 [460]	830 [392]	1070 [505]	975 [460]	830 [392]	1070 [505]	975 [460]	830 [392]	
DR ①		0.16	0.14	0.1	0.16	0.14	0.1	0.16	0.14	0.1	
OUTDOOR DRY BULB TEMPERATURE °F [°C]	75 [23.9]	Total BTUH [kW] Sens BTUH [kW] Power	36.8 [10.8] 21.5 [6.3] 1.7	36.1 [10.6] 20.5 [6.0] 1.7	35.2 [10.3] 19.1 [5.6] 1.6	34.3 [10.1] 25.1 [7.4] 1.7	33.7 [9.9] 24.0 [7.0] 1.6	32.8 [9.6] 22.4 [6.6] 1.6	32.4 [9.5] 28.3 [8.3] 1.6	31.8 [9.3] 27.1 [7.9] 1.6	31.0 [9.1] 25.2 [7.4] 1.6
	80 [26.7]	Total BTUH [kW] Sens BTUH [kW] Power	35.7 [10.5] 21.0 [6.1] 1.8	35.1 [10.3] 20.1 [5.9] 1.7	34.2 [10.0] 18.7 [5.5] 1.7	33.3 [9.7] 24.7 [7.2] 1.7	32.7 [9.6] 23.6 [6.9] 1.7	31.8 [9.3] 21.9 [6.4] 1.7	31.3 [9.2] 27.8 [8.2] 1.7	30.8 [9.0] 26.6 [7.8] 1.7	30.0 [8.8] 24.8 [7.3] 1.7
	85 [29.4]	Total BTUH [kW] Sens BTUH [kW] Power	34.7 [10.2] 20.5 [6.0] 1.9	34.1 [10.0] 19.6 [5.7] 1.8	33.2 [9.7] 18.2 [5.3] 1.8	32.2 [9.4] 24.2 [7.1] 1.8	31.7 [9.3] 23.1 [6.8] 1.8	30.8 [9.0] 21.5 [6.3] 1.8	30.3 [8.9] 27.4 [8.0] 1.8	29.8 [8.7] 26.2 [7.7] 1.8	29.0 [8.5] 24.3 [7.1] 1.8
	90 [32.2]	Total BTUH [kW] Sens BTUH [kW] Power	33.7 [9.9] 20.0 [5.9] 2.0	33.1 [9.7] 19.1 [5.6] 1.9	32.2 [9.4] 17.8 [5.2] 1.9	31.2 [9.1] 23.6 [6.9] 1.9	30.6 [9.0] 22.6 [6.6] 1.9	29.8 [8.7] 21.0 [6.2] 1.9	29.2 [8.6] 26.8 [7.9] 1.9	28.7 [8.4] 25.7 [7.5] 1.9	28.0 [8.2] 23.9 [7.0] 1.9
	95 [35]	Total BTUH [kW] Sens BTUH [kW] Power	32.6 [9.5] 19.4 [5.7] 2.1	32.0 [9.4] 18.6 [5.4] 2.1	31.2 [9.1] 17.3 [5.1] 2.0	30.1 [8.8] 23.1 [6.8] 2.1	29.6 [8.7] 22.1 [6.5] 2.0	28.8 [8.4] 20.5 [6.0] 2.0	28.2 [8.3] 26.3 [7.7] 2.0	27.7 [8.1] 25.1 [7.4] 2.0	26.9 [7.9] 23.4 [6.9] 2.0
	100 [37.8]	Total BTUH [kW] Sens BTUH [kW] Power	31.5 [9.2] 18.8 [5.5] 2.2	31.0 [9.1] 18.0 [5.3] 2.2	30.1 [8.8] 16.8 [4.9] 2.1	29.0 [8.5] 22.5 [6.6] 2.2	28.5 [8.4] 21.5 [6.3] 2.2	27.7 [8.1] 20.0 [5.9] 2.1	27.1 [7.9] 25.7 [7.5] 2.2	26.6 [7.8] 24.6 [7.2] 2.1	25.9 [7.6] 22.9 [6.7] 2.1
	105 [40.6]	Total BTUH [kW] Sens BTUH [kW] Power	30.4 [8.9] 18.2 [5.3] 2.3	29.9 [8.8] 17.4 [5.1] 2.3	29.1 [8.5] 16.2 [4.8] 2.3	27.9 [8.2] 21.9 [6.4] 2.3	27.4 [8.0] 20.9 [6.1] 2.3	26.7 [7.8] 19.5 [5.7] 2.3	26.0 [7.6] 25.1 [7.4] 2.3	25.6 [7.5] 24.0 [7.0] 2.3	24.9 [7.3] 22.3 [6.5] 2.2
	110 [43.3]	Total BTUH [kW] Sens BTUH [kW] Power	29.3 [8.6] 17.6 [5.2] 2.5	28.8 [8.4] 16.8 [4.9] 2.4	28.0 [8.2] 15.7 [4.6] 2.4	26.8 [7.9] 21.3 [6.2] 2.4	26.4 [7.7] 20.3 [6.0] 2.4	25.6 [7.5] 18.9 [5.5] 2.4	24.9 [7.3] 24.4 [7.2] 2.4	24.5 [7.2] 23.4 [6.9] 2.4	23.8 [7.0] 21.8 [6.4] 2.4
	115 [46.1]	Total BTUH [kW] Sens BTUH [kW] Power	28.2 [8.3] 16.9 [5.0] 2.6	27.7 [8.1] 16.2 [4.7] 2.6	27.0 [7.9] 15.1 [4.4] 2.5	25.7 [7.5] 20.6 [6.0] 2.6	25.3 [7.4] 19.7 [5.8] 2.6	24.6 [7.2] 18.3 [5.4] 2.5	23.8 [7.0] 23.8 [7.0] 2.6	23.4 [6.8] 22.7 [6.7] 2.6	22.7 [6.7] 21.2 [6.2] 2.5
	120 [48.9]	Total BTUH [kW] Sens BTUH [kW] Power	27.1 [7.9] 16.2 [4.8] 2.8	26.6 [7.8] 15.5 [4.5] 2.7	25.9 [7.6] 14.4 [4.2] 2.7	24.6 [7.2] 19.9 [5.8] 2.7	24.2 [7.1] 19.0 [5.6] 2.7	23.5 [6.9] 17.7 [5.2] 2.7	22.7 [6.6] 22.7 [6.6] 2.7	22.3 [6.5] 22.1 [6.5] 2.7	21.7 [6.3] 20.5 [6.0] 2.7
	125 [51.7]	Total BTUH [kW] Sens BTUH [kW] Power	25.9 [7.6] 15.5 [4.5] 2.9	25.5 [7.5] 14.8 [4.3] 2.9	24.8 [7.3] 13.8 [4.0] 2.8	23.4 [6.9] 19.2 [5.6] 2.9	23.0 [6.7] 18.3 [5.4] 2.9	22.4 [6.6] 17.1 [5.0] 2.8	21.5 [6.3] 21.5 [6.3] 2.9	21.1 [6.2] 21.1 [6.2] 2.9	20.6 [6.0] 19.9 [5.8] 2.8

DR —Depression ratio
dbE —Entering air dry bulb
wbE—Entering air wet bulb

Total —Total capacity x 1000 BTUH
Sens —Sensible capacity x 1000 BTUH
Power —KW input

NOTES: ① When the entering air dry bulb is other than 80°F [27°C], adjust the sensible capacity from the table by adding [1.10 x CFM x (1 - DR) x (dbE - 80)].

[] Designates Metric Conversions





GROSS SYSTEMS PERFORMANCE DATA – RGEA14036A

wbE		ENTERING INDOOR AIR @ 80°F [26.7°C] dbE ①									
		71°F [21.7°C]			67°F [19.4°C]			63°F [17.2°C]			
CFM [L/s]		1320 [623]	1200 [566]	1020 [481]	1320 [623]	1200 [566]	1020 [481]	1320 [623]	1200 [566]	1020 [481]	
DR ①		0.19	0.18	0.15	0.19	0.18	0.15	0.19	0.18	0.15	
OUTDOOR DRY BULB TEMPERATURE °F [°C]	75 [23.9]	Total BTUH [kW] Sens BTUH [kW] Power	44.8 [13.1] 26.2 [7.7] 2.0	44.0 [12.9] 25.0 [7.3] 2.0	42.8 [12.5] 23.3 [6.8] 2.0	41.9 [12.3] 30.6 [9.0] 2.0	41.1 [12.1] 29.2 [8.6] 2.0	40.0 [11.7] 27.2 [8.0] 2.0	38.9 [11.4] 33.9 [9.9] 2.0	38.2 [11.2] 32.4 [9.5] 2.0	37.2 [10.9] 30.1 [8.8] 2.0
	80 [26.7]	Total BTUH [kW] Sens BTUH [kW] Power	43.5 [12.8] 25.4 [7.5] 2.1	42.7 [12.5] 24.3 [7.1] 2.1	41.6 [12.2] 22.6 [6.6] 2.1	40.6 [11.9] 29.9 [8.7] 2.1	39.9 [11.7] 28.5 [8.4] 2.1	38.8 [11.4] 26.5 [7.8] 2.1	37.6 [11.0] 33.2 [9.7] 2.1	36.9 [10.8] 31.7 [9.3] 2.1	35.9 [10.5] 29.5 [8.6] 2.1
	85 [29.4]	Total BTUH [kW] Sens BTUH [kW] Power	42.2 [12.4] 24.7 [7.2] 2.3	41.4 [12.1] 23.6 [6.9] 2.2	40.3 [11.8] 21.9 [6.4] 2.2	39.3 [11.5] 29.1 [8.5] 2.2	38.6 [11.3] 27.8 [8.1] 2.2	37.5 [11.0] 25.9 [7.6] 2.2	36.3 [10.6] 32.4 [9.5] 2.2	35.6 [10.4] 31.0 [9.1] 2.2	34.6 [10.2] 28.8 [8.4] 2.2
	90 [32.2]	Total BTUH [kW] Sens BTUH [kW] Power	40.9 [12.0] 23.9 [7.0] 2.4	40.1 [11.8] 22.9 [6.7] 2.4	39.0 [11.4] 21.3 [6.2] 2.3	37.9 [11.1] 28.3 [8.3] 2.4	37.2 [10.9] 27.1 [7.9] 2.4	36.2 [10.6] 25.2 [7.4] 2.3	34.9 [10.2] 31.6 [9.3] 2.4	34.3 [10.1] 30.2 [8.9] 2.3	33.4 [9.8] 28.1 [8.2] 2.3
	95 [35]	Total BTUH [kW] Sens BTUH [kW] Power	39.5 [11.6] 23.1 [6.8] 2.5	38.8 [11.4] 22.1 [6.5] 2.5	37.7 [11.1] 20.6 [6.0] 2.5	36.6 [10.7] 27.5 [8.1] 2.5	35.9 [10.5] 26.3 [7.7] 2.5	34.9 [10.2] 24.5 [7.2] 2.5	33.6 [9.8] 30.9 [9.0] 2.5	33.0 [9.7] 29.5 [8.6] 2.5	32.1 [9.4] 27.4 [8.0] 2.5
	100 [37.8]	Total BTUH [kW] Sens BTUH [kW] Power	38.1 [11.2] 22.3 [6.5] 2.7	37.5 [11.0] 21.3 [6.3] 2.7	36.4 [10.7] 19.9 [5.8] 2.6	35.2 [10.3] 26.7 [7.8] 2.7	34.6 [10.1] 25.6 [7.5] 2.7	33.6 [9.9] 23.8 [7.0] 2.6	32.2 [9.4] 30.1 [8.8] 2.7	31.6 [9.3] 28.7 [8.4] 2.6	30.8 [9.0] 26.7 [7.8] 2.6
	105 [40.6]	Total BTUH [kW] Sens BTUH [kW] Power	36.8 [10.8] 21.5 [6.3] 2.9	36.1 [10.6] 20.6 [6.0] 2.8	35.1 [10.3] 19.1 [5.6] 2.8	33.8 [9.9] 25.9 [7.6] 2.8	33.2 [9.7] 24.8 [7.3] 2.8	32.3 [9.5] 23.0 [6.7] 2.8	30.8 [9.0] 29.2 [8.6] 2.8	30.3 [8.9] 27.9 [8.2] 2.8	29.5 [8.6] 26.0 [7.6] 2.8
	110 [43.3]	Total BTUH [kW] Sens BTUH [kW] Power	35.4 [10.4] 20.7 [6.1] 3.0	34.7 [10.2] 19.8 [5.8] 3.0	33.8 [9.9] 18.4 [5.4] 3.0	32.4 [9.5] 25.1 [7.4] 3.0	31.9 [9.3] 24.0 [7.0] 3.0	31.0 [9.1] 22.3 [6.5] 3.0	29.4 [8.6] 28.4 [8.3] 3.0	28.9 [8.5] 27.1 [8.0] 3.0	28.1 [8.2] 25.2 [7.4] 2.9
	115 [46.1]	Total BTUH [kW] Sens BTUH [kW] Power	34.0 [10.0] 19.8 [5.8] 3.2	33.4 [9.8] 18.9 [5.5] 3.2	32.4 [9.5] 17.6 [5.2] 3.2	31.0 [9.1] 24.2 [7.1] 3.2	30.5 [8.9] 23.1 [6.8] 3.2	29.6 [8.7] 21.5 [6.3] 3.1	28.0 [8.2] 27.5 [8.1] 3.2	27.5 [8.1] 26.3 [7.7] 3.2	26.8 [7.8] 24.5 [7.2] 3.1
	120 [48.9]	Total BTUH [kW] Sens BTUH [kW] Power	32.5 [9.5] 18.9 [5.6] 3.4	32.0 [9.4] 18.1 [5.3] 3.4	31.1 [9.1] 16.8 [4.9] 3.4	29.6 [8.7] 23.3 [6.8] 3.4	29.1 [8.5] 22.3 [6.5] 3.4	28.3 [8.3] 20.7 [6.1] 3.3	26.6 [7.8] 26.6 [7.8] 3.4	26.1 [7.7] 25.5 [7.5] 3.4	25.4 [7.4] 23.7 [6.9] 3.3
	125 [51.7]	Total BTUH [kW] Sens BTUH [kW] Power	31.1 [9.1] 18.0 [5.3] 3.6	30.5 [9.0] 17.2 [5.1] 3.6	29.7 [8.7] 16.0 [4.7] 3.6	28.2 [8.3] 22.4 [6.6] 3.6	27.7 [8.1] 21.4 [6.3] 3.6	26.9 [7.9] 19.9 [5.8] 3.6	25.2 [7.4] 25.2 [7.4] 3.6	24.7 [7.2] 24.6 [7.2] 3.6	24.1 [7.0] 22.9 [6.7] 3.5

DR —Depression ratio
dbE —Entering air dry bulb
wbE—Entering air wet bulb

Total —Total capacity x 1000 BTUH
Sens —Sensible capacity x 1000 BTUH
Power —KW input

NOTES: ① When the entering air dry bulb is other than 80°F [27°C], adjust the sensible capacity from the table by adding [1.10 x CFM x (1 – DR) x (dbE – 80)].

[] Designates Metric Conversions





GROSS SYSTEMS PERFORMANCE DATA—RGEA14042A

		ENTERING INDOOR AIR @ 80°F [26.7°C] dbE ①									
		71°F [21.7°C]			67°F [19.4°C]			63°F [17.2°C]			
wbE		1430 [675]	1300 [614]	1100 [519]	1430 [675]	1300 [614]	1100 [519]	1430 [675]	1300 [614]	1100 [519]	
CFM [L/s]		1430 [675]	1300 [614]	1100 [519]	1430 [675]	1300 [614]	1100 [519]	1430 [675]	1300 [614]	1100 [519]	
DR ①		0.15	0.14	0.1	0.15	0.14	0.1	0.15	0.14	0.1	
OUTDOOR DRY BULB TEMPERATURE °F [°C]	75 [23.9]	Total BTUH [kW] Sens BTUH [kW] Power	50.0 [14.7] 29.2 [8.5] 2.4	49.1 [14.4] 27.9 [8.2] 2.4	47.7 [14.0] 25.9 [7.6] 2.3	47.3 [13.9] 34.3 [10.0] 2.4	46.4 [13.6] 32.7 [9.6] 2.3	45.1 [13.2] 30.4 [8.9] 2.3	44.3 [13.0] 38.5 [11.3] 2.3	43.5 [12.8] 36.8 [10.8] 2.3	42.3 [12.4] 34.2 [10.0] 2.3
	80 [26.7]	Total BTUH [kW] Sens BTUH [kW] Power	48.7 [14.3] 28.5 [8.4] 2.5	47.9 [14.0] 27.3 [8.0] 2.5	46.5 [13.6] 25.3 [7.4] 2.5	46.0 [13.5] 33.7 [9.9] 2.5	45.2 [13.2] 32.2 [9.4] 2.5	43.9 [12.9] 29.8 [8.7] 2.4	43.0 [12.6] 37.9 [11.1] 2.5	42.3 [12.4] 36.2 [10.6] 2.5	41.1 [12.0] 33.6 [9.9] 2.4
	85 [29.4]	Total BTUH [kW] Sens BTUH [kW] Power	47.4 [13.9] 27.9 [8.2] 2.7	46.6 [13.6] 26.6 [7.8] 2.6	45.2 [13.3] 24.7 [7.2] 2.6	44.7 [13.1] 33.0 [9.7] 2.6	43.9 [12.9] 31.5 [9.2] 2.6	42.6 [12.5] 29.3 [8.6] 2.6	41.7 [12.2] 37.2 [10.9] 2.6	41.0 [12.0] 35.6 [10.4] 2.6	39.8 [11.7] 33.0 [9.7] 2.6
	90 [32.2]	Total BTUH [kW] Sens BTUH [kW] Power	46.0 [13.5] 27.2 [8.0] 2.8	45.2 [13.2] 26.0 [7.6] 2.8	43.9 [12.9] 24.1 [7.1] 2.8	43.3 [12.7] 32.3 [9.5] 2.8	42.5 [12.5] 30.8 [9.0] 2.8	41.3 [12.1] 28.6 [8.4] 2.7	40.3 [11.8] 36.5 [10.7] 2.8	39.6 [11.6] 34.9 [10.2] 2.8	38.5 [11.3] 32.4 [9.5] 2.7
	95 [35]	Total BTUH [kW] Sens BTUH [kW] Power	44.6 [13.1] 26.4 [7.7] 3.0	43.8 [12.8] 25.2 [7.4] 3.0	42.6 [12.5] 23.4 [6.9] 2.9	41.8 [12.3] 31.5 [9.2] 3.0	41.1 [12.0] 30.1 [8.8] 3.0	39.9 [11.7] 27.9 [8.2] 2.9	38.9 [11.4] 35.8 [10.5] 3.0	38.2 [11.2] 34.2 [10.0] 2.9	37.1 [10.9] 31.7 [9.3] 2.9
	100 [37.8]	Total BTUH [kW] Sens BTUH [kW] Power	43.1 [12.6] 25.6 [7.5] 3.2	42.3 [12.4] 24.4 [7.2] 3.1	41.1 [12.1] 22.7 [6.6] 3.1	40.4 [11.8] 30.7 [9.0] 3.2	39.6 [11.6] 29.3 [8.6] 3.1	38.5 [11.3] 27.2 [8.0] 3.1	37.4 [11.0] 34.9 [10.2] 3.1	36.7 [10.8] 33.4 [9.8] 3.1	35.7 [10.5] 31.0 [9.1] 3.1
	105 [40.6]	Total BTUH [kW] Sens BTUH [kW] Power	41.6 [12.2] 24.7 [7.2] 3.4	40.8 [12.0] 23.6 [6.9] 3.3	39.7 [11.6] 21.9 [6.4] 3.3	38.8 [11.4] 29.8 [8.7] 3.3	38.1 [11.2] 28.5 [8.3] 3.3	37.1 [10.9] 26.4 [7.7] 3.3	35.9 [10.5] 34.1 [10.0] 3.3	35.2 [10.3] 32.5 [9.5] 3.3	34.3 [10.0] 30.2 [8.8] 3.3
	110 [43.3]	Total BTUH [kW] Sens BTUH [kW] Power	40.0 [11.7] 23.8 [7.0] 3.6	39.3 [11.5] 22.7 [6.7] 3.5	38.2 [11.2] 21.1 [6.2] 3.5	37.2 [10.9] 28.9 [8.5] 3.5	36.6 [10.7] 27.6 [8.1] 3.5	35.6 [10.4] 25.6 [7.5] 3.5	34.3 [10.0] 33.1 [9.7] 3.5	33.7 [9.9] 31.6 [9.3] 3.5	32.7 [9.6] 29.4 [8.6] 3.5
	115 [46.1]	Total BTUH [kW] Sens BTUH [kW] Power	38.3 [11.2] 22.8 [6.7] 3.8	37.7 [11.0] 21.8 [6.4] 3.7	36.6 [10.7] 20.2 [5.9] 3.7	35.6 [10.4] 27.9 [8.2] 3.8	35.0 [10.2] 26.6 [7.8] 3.7	34.0 [10.0] 24.7 [7.2] 3.7	32.7 [9.6] 32.1 [9.4] 3.7	32.1 [9.4] 30.7 [9.0] 3.7	31.2 [9.1] 28.5 [8.4] 3.7
	120 [48.9]	Total BTUH [kW] Sens BTUH [kW] Power	36.7 [10.7] 21.7 [6.4] 4.0	36.0 [10.6] 20.8 [6.1] 4.0	35.0 [10.3] 19.3 [5.6] 3.9	33.9 [9.9] 26.8 [7.9] 4.0	33.3 [9.8] 25.6 [7.5] 3.9	32.4 [9.5] 23.8 [7.0] 3.9	31.0 [9.1] 31.0 [9.1] 4.0	30.4 [8.9] 29.7 [8.7] 3.9	29.6 [8.7] 27.6 [8.1] 3.9
	125 [51.7]	Total BTUH [kW] Sens BTUH [kW] Power	34.9 [10.2] 20.6 [6.1] 4.2	34.3 [10.1] 19.7 [5.8] 4.2	33.3 [9.8] 18.3 [5.4] 4.1	32.2 [9.4] 25.8 [7.5] 4.2	31.6 [9.3] 24.6 [7.2] 4.2	30.7 [9.0] 22.8 [6.7] 4.1	29.2 [8.6] 29.2 [8.6] 4.2	28.7 [8.4] 28.7 [8.4] 4.1	27.9 [8.2] 26.6 [7.8] 4.1

DR —Depression ratio
dbE —Entering air dry bulb
wbE —Entering air wet bulb

Total —Total capacity x 1000 BTUH
Sens —Sensible capacity x 1000 BTUH
Power —kW input

NOTES: ① When the entering air dry bulb is other than 80°F [27°C], adjust the sensible capacity from the table by adding [1.10 x CFM x (1 - DR) x (dbE - 80)].

[] Designates Metric Conversions





GROSS SYSTEMS PERFORMANCE DATA – RGEA14048A

		ENTERING INDOOR AIR @ 80°F [26.7°C] dbE ①									
		71°F [21.7°C]			67°F [19.4°C]			63°F [17.2°C]			
wbE		1700 [802]	1550 [732]	1320 [623]	1700 [802]	1550 [732]	1320 [623]	1700 [802]	1550 [732]	1320 [623]	
CFM [L/s]		1700 [802]	1550 [732]	1320 [623]	1700 [802]	1550 [732]	1320 [623]	1700 [802]	1550 [732]	1320 [623]	
DR ①		0.19	0.18	0.15	0.19	0.18	0.15	0.19	0.18	0.15	
OUTDOOR DRY BULB TEMPERATURE °F [°C]	75 [23.9]	Total BTUH [kW] Sens BTUH [kW] Power	58.3 [17.1] 33.2 [9.7] 2.7	57.3 [16.8] 31.8 [9.3] 2.6	55.8 [16.3] 29.6 [8.7] 2.6	54.6 [16.0] 39.2 [11.5] 2.7	53.7 [15.7] 37.5 [11.0] 2.6	52.2 [15.3] 34.9 [10.2] 2.6	51.6 [15.1] 44.7 [13.1] 2.6	50.7 [14.9] 42.8 [12.5] 2.6	49.3 [14.5] 39.8 [11.7] 2.6
	80 [26.7]	Total BTUH [kW] Sens BTUH [kW] Power	56.8 [16.7] 32.5 [9.5] 2.8	55.8 [16.4] 31.1 [9.1] 2.8	54.3 [15.9] 28.9 [8.5] 2.8	53.1 [15.6] 38.5 [11.3] 2.8	52.2 [15.3] 36.8 [10.8] 2.8	50.8 [14.9] 34.3 [10.0] 2.7	50.1 [14.7] 44.0 [12.9] 2.8	49.2 [14.4] 42.1 [12.3] 2.8	47.9 [14.0] 39.2 [11.5] 2.7
	85 [29.4]	Total BTUH [kW] Sens BTUH [kW] Power	55.3 [16.2] 31.7 [9.3] 3.0	54.3 [15.9] 30.3 [8.9] 2.9	52.8 [15.5] 28.2 [8.3] 2.9	51.5 [15.1] 37.7 [11.0] 2.9	50.6 [14.8] 36.0 [10.6] 2.9	49.3 [14.4] 33.6 [9.8] 2.9	48.5 [14.2] 43.2 [12.7] 2.9	47.7 [14.0] 41.3 [12.1] 2.9	46.4 [13.6] 38.4 [11.3] 2.9
	90 [32.2]	Total BTUH [kW] Sens BTUH [kW] Power	53.6 [15.7] 30.8 [9.0] 3.1	52.7 [15.4] 29.5 [8.6] 3.1	51.3 [15.0] 27.4 [8.0] 3.1	49.9 [14.6] 36.8 [10.8] 3.1	49.0 [14.4] 35.2 [10.3] 3.1	47.7 [14.0] 32.8 [9.6] 3.0	46.9 [13.7] 42.3 [12.4] 3.1	46.1 [13.5] 40.5 [11.9] 3.1	44.8 [13.1] 37.7 [11.0] 3.0
	95 [35]	Total BTUH [kW] Sens BTUH [kW] Power	51.9 [15.2] 29.9 [8.8] 3.3	51.0 [14.9] 28.6 [8.4] 3.3	49.6 [14.5] 26.6 [7.8] 3.2	48.2 [14.1] 35.9 [10.5] 3.3	47.3 [13.9] 34.3 [10.1] 3.3	46.1 [13.5] 32.0 [9.4] 3.2	45.2 [13.2] 41.4 [12.1] 3.3	44.4 [13.0] 39.6 [11.6] 3.3	43.2 [12.7] 36.8 [10.8] 3.2
	100 [37.8]	Total BTUH [kW] Sens BTUH [kW] Power	50.1 [14.7] 28.9 [8.5] 3.5	49.2 [14.4] 27.6 [8.1] 3.5	47.9 [14.0] 25.7 [7.5] 3.4	46.4 [13.6] 34.9 [10.2] 3.5	45.6 [13.4] 33.4 [9.8] 3.5	44.3 [13.0] 31.1 [9.1] 3.4	43.4 [12.7] 40.4 [11.8] 3.5	42.6 [12.5] 38.6 [11.3] 3.4	41.5 [12.2] 36.0 [10.5] 3.4
	105 [40.6]	Total BTUH [kW] Sens BTUH [kW] Power	48.2 [14.1] 27.8 [8.2] 3.7	47.4 [13.9] 26.6 [7.8] 3.7	46.1 [13.5] 24.8 [7.3] 3.6	44.5 [13.0] 33.8 [9.9] 3.7	43.7 [12.8] 32.4 [9.5] 3.7	42.6 [12.5] 30.1 [8.8] 3.6	41.5 [12.2] 39.3 [11.5] 3.7	40.8 [12.0] 37.6 [11.0] 3.7	39.7 [11.6] 35.0 [10.3] 3.6
	110 [43.3]	Total BTUH [kW] Sens BTUH [kW] Power	46.3 [13.6] 26.7 [7.8] 3.9	45.5 [13.3] 25.6 [7.5] 3.9	44.3 [13.0] 23.8 [7.0] 3.9	42.6 [12.5] 32.7 [9.6] 3.9	41.9 [12.3] 31.3 [9.2] 3.9	40.7 [11.9] 29.1 [8.5] 3.8	39.6 [11.6] 38.2 [11.2] 3.9	38.9 [11.4] 36.6 [10.7] 3.9	37.9 [11.1] 34.0 [10.0] 3.8
	115 [46.1]	Total BTUH [kW] Sens BTUH [kW] Power	44.3 [13.0] 25.5 [7.5] 4.2	43.5 [12.8] 24.4 [7.2] 4.2	42.4 [12.4] 22.7 [6.7] 4.1	40.6 [11.9] 31.6 [9.2] 4.2	39.9 [11.7] 30.2 [8.8] 4.1	38.8 [11.4] 28.1 [8.2] 4.1	37.6 [11.0] 37.1 [10.9] 4.2	36.9 [10.8] 35.5 [10.4] 4.1	35.9 [10.5] 33.0 [9.7] 4.1
	120 [48.9]	Total BTUH [kW] Sens BTUH [kW] Power	42.2 [12.4] 24.3 [7.1] 4.4	41.5 [12.2] 23.3 [6.8] 4.4	40.4 [11.8] 21.7 [6.3] 4.3	38.5 [11.3] 30.3 [8.9] 4.4	37.9 [11.1] 29.0 [8.5] 4.4	36.8 [10.8] 27.0 [7.9] 4.3	35.5 [10.4] 35.5 [10.4] 4.4	34.9 [10.2] 34.3 [10.0] 4.4	34.0 [10.0] 31.9 [9.3] 4.3
	125 [51.7]	Total BTUH [kW] Sens BTUH [kW] Power	40.1 [11.8] 23.0 [6.7] 4.7	39.4 [11.5] 22.0 [6.5] 4.7	38.3 [11.2] 20.5 [6.0] 4.6	36.4 [10.7] 29.0 [8.5] 4.7	35.7 [10.5] 27.8 [8.1] 4.6	34.8 [10.2] 25.9 [7.6] 4.6	33.4 [9.8] 33.4 [9.8] 4.7	32.8 [9.6] 32.8 [9.6] 4.6	31.9 [9.4] 30.8 [9.0] 4.6

DR —Depression ratio
dbE —Entering air dry bulb
wbE—Entering air wet bulb

Total —Total capacity x 1000 BTUH
Sens —Sensible capacity x 1000 BTUH
Power —KW input

NOTES: ① When the entering air dry bulb is other than 80°F [27°C], adjust the sensible capacity from the table by adding [1.10 x CFM x (1 – DR) x (dbE – 80)].

[] Designates Metric Conversions



GROSS SYSTEMS PERFORMANCE DATA—RGEA14060A

wbE		ENTERING INDOOR AIR @ 80°F [26.7°C] dbE ①									
		71°F [21.7°C]			67°F [19.4°C]			63°F [17.2°C]			
CFM [L/s]		2040 [963]	1850 [873]	1570 [741]	2040 [963]	1850 [873]	1570 [741]	2040 [963]	1850 [873]	1570 [741]	
DR ①		0.15	0.14	0.11	0.15	0.14	0.11	0.15	0.14	0.11	
OUTDOOR DRY BULB TEMPERATURE °F [°C]	75 [23.9]	Total BTUH [kW] Sens BTUH [kW] Power	73.0 [21.4] 42.4 [12.4] 3.6	71.7 [21.0] 40.5 [11.9] 3.6	69.7 [20.4] 37.6 [11.0] 3.5	69.2 [20.3] 50.0 [14.6] 3.6	67.9 [19.9] 47.7 [14.0] 3.5	66.0 [19.3] 44.3 [13.0] 3.5	65.8 [19.3] 56.9 [16.7] 3.5	64.6 [18.9] 54.3 [15.9] 3.5	62.8 [18.4] 50.5 [14.8] 3.4
	80 [26.7]	Total BTUH [kW] Sens BTUH [kW] Power	70.9 [20.8] 41.3 [12.1] 3.8	69.6 [20.4] 39.4 [11.6] 3.7	67.7 [19.8] 36.6 [10.7] 3.7	67.1 [19.6] 48.8 [14.3] 3.7	65.8 [19.3] 46.6 [13.7] 3.7	64.0 [18.8] 43.3 [12.7] 3.6	63.7 [18.7] 55.8 [16.4] 3.7	62.5 [18.3] 53.2 [15.6] 3.7	60.8 [17.8] 49.5 [14.5] 3.6
	85 [29.4]	Total BTUH [kW] Sens BTUH [kW] Power	68.8 [20.2] 40.1 [11.8] 4.0	67.6 [19.8] 38.3 [11.2] 3.9	65.7 [19.3] 35.6 [10.4] 3.9	64.9 [19.0] 47.7 [14.0] 3.9	63.7 [18.7] 45.5 [13.3] 3.9	62.0 [18.2] 42.3 [12.4] 3.8	61.5 [18.0] 54.6 [16.0] 3.9	60.4 [17.7] 52.1 [15.3] 3.8	58.8 [17.2] 48.5 [14.2] 3.8
	90 [32.2]	Total BTUH [kW] Sens BTUH [kW] Power	66.7 [19.5] 38.9 [11.4] 4.2	65.4 [19.2] 37.2 [10.9] 4.1	63.6 [18.6] 34.5 [10.1] 4.1	62.8 [18.4] 46.5 [13.6] 4.1	61.6 [18.1] 44.3 [13.0] 4.1	59.9 [17.6] 41.2 [12.1] 4.0	59.4 [17.4] 53.4 [15.7] 4.1	58.3 [17.1] 51.0 [14.9] 4.0	56.7 [16.6] 47.4 [13.9] 4.0
	95 [35]	Total BTUH [kW] Sens BTUH [kW] Power	64.5 [18.9] 37.7 [11.0] 4.4	63.3 [18.5] 36.0 [10.5] 4.3	61.5 [18.0] 33.4 [9.8] 4.3	60.6 [17.7] 45.2 [13.3] 4.3	59.5 [17.4] 43.2 [12.6] 4.3	57.8 [16.9] 40.1 [11.8] 4.2	57.2 [16.8] 52.2 [15.3] 4.3	56.1 [16.5] 49.8 [14.6] 4.3	54.6 [16.0] 46.3 [13.6] 4.2
	100 [37.8]	Total BTUH [kW] Sens BTUH [kW] Power	62.2 [18.2] 36.4 [10.7] 4.6	61.1 [17.9] 34.7 [10.2] 4.6	59.4 [17.4] 32.3 [9.5] 4.5	58.3 [17.1] 43.9 [12.9] 4.6	57.3 [16.8] 41.9 [12.3] 4.5	55.7 [16.3] 39.0 [11.4] 4.5	55.0 [16.1] 50.9 [14.9] 4.5	54.0 [15.8] 48.6 [14.2] 4.5	52.5 [15.4] 45.1 [13.2] 4.4
	105 [40.6]	Total BTUH [kW] Sens BTUH [kW] Power	60.0 [17.6] 35.1 [10.3] 4.9	58.9 [17.3] 33.5 [9.8] 4.8	57.3 [16.8] 31.1 [9.1] 4.8	56.1 [16.4] 42.6 [12.5] 4.8	55.1 [16.1] 40.7 [11.9] 4.8	53.5 [15.7] 37.8 [11.1] 4.7	52.7 [15.4] 49.6 [14.5] 4.8	51.8 [15.2] 47.3 [13.9] 4.8	50.3 [14.7] 44.0 [12.9] 4.7
	110 [43.3]	Total BTUH [kW] Sens BTUH [kW] Power	57.7 [16.9] 33.7 [9.9] 5.2	56.6 [16.6] 32.2 [9.4] 5.1	55.1 [16.1] 29.9 [8.8] 5.0	53.8 [15.8] 41.2 [12.1] 5.1	52.8 [15.5] 39.3 [11.5] 5.1	51.4 [15.1] 36.6 [10.7] 5.0	50.4 [14.8] 48.2 [14.1] 5.1	49.5 [14.5] 46.0 [13.5] 5.0	48.1 [14.1] 42.7 [12.5] 5.0
	115 [46.1]	Total BTUH [kW] Sens BTUH [kW] Power	55.4 [16.2] 32.3 [9.5] 5.4	54.4 [15.9] 30.8 [9.0] 5.4	52.9 [15.5] 28.6 [8.4] 5.3	51.5 [15.1] 39.8 [11.7] 5.4	50.5 [14.8] 38.0 [11.1] 5.4	49.2 [14.4] 35.3 [10.3] 5.3	48.1 [14.1] 46.8 [13.7] 5.4	47.2 [13.8] 44.6 [13.1] 5.3	45.9 [13.5] 41.5 [12.2] 5.2
	120 [48.9]	Total BTUH [kW] Sens BTUH [kW] Power	53.0 [15.5] 30.8 [9.0] 5.8	52.1 [15.3] 29.4 [8.6] 5.7	50.6 [14.8] 27.3 [8.0] 5.6	49.1 [14.4] 38.4 [11.2] 5.7	48.2 [14.1] 36.6 [10.7] 5.7	46.9 [13.7] 34.0 [10.0] 5.6	45.8 [13.4] 45.3 [13.3] 5.7	44.9 [13.2] 43.2 [12.7] 5.6	43.7 [12.8] 40.2 [11.8] 5.5
	125 [51.7]	Total BTUH [kW] Sens BTUH [kW] Power	50.7 [14.8] 29.3 [8.6] 6.1	49.7 [14.6] 28.0 [8.2] 6.0	48.4 [14.2] 26.0 [7.6] 6.0	46.8 [13.7] 36.9 [10.8] 6.0	45.9 [13.5] 35.2 [10.3] 6.0	44.6 [13.1] 32.7 [9.6] 5.9	43.4 [12.7] 43.4 [12.7] 6.0	42.6 [12.5] 41.8 [12.3] 6.0	41.4 [12.1] 38.9 [11.4] 5.9

DR —Depression ratio
dbE —Entering air dry bulb
wbE—Entering air wet bulb

Total —Total capacity x 1000 BTUH
Sens —Sensible capacity x 1000 BTUH
Power —kW input

NOTES: ① When the entering air dry bulb is other than 80°F [27°C], adjust the sensible capacity from the table by adding [1.10 x CFM x (1 - DR) x (dbE - 80)].

[] Designates Metric Conversions



GROSS SYSTEMS PERFORMANCE DATA – RGEA15024A

ENTERING INDOOR AIR @ 80°F [26.7°C] dbE ①											
wbE		71°F [21.7°C]			67°F [19.4°C]			63°F [17.2°C]			
CFM [L/s]		990 [467]	900 [425]	760 [359]	990 [467]	900 [425]	760 [359]	990 [467]	900 [425]	760 [359]	
DR ①		0.21	0.19	0.15	0.21	0.19	0.15	0.21	0.19	0.15	
OUTDOOR DRY BULB TEMPERATURE °F [°C]	75 [23.9]	Total BTUH [kW] Sens BTUH [kW] Power	30.9 [9.1] 18.7 [5.5] 1.4	30.4 [8.9] 17.9 [5.2] 1.4	29.5 [8.7] 16.6 [4.9] 1.4	29.1 [8.5] 21.9 [6.4] 1.4	28.6 [8.4] 20.9 [6.1] 1.4	27.8 [8.1] 19.4 [5.7] 1.4	27.5 [8.1] 24.6 [7.2] 1.4	27.0 [7.9] 23.5 [6.9] 1.4	26.2 [7.7] 21.8 [6.4] 1.4
	80 [26.7]	Total BTUH [kW] Sens BTUH [kW] Power	30.0 [8.8] 18.2 [5.3] 1.5	29.4 [8.6] 17.4 [5.1] 1.5	28.6 [8.4] 16.1 [4.7] 1.5	28.1 [8.2] 21.4 [6.3] 1.5	27.6 [8.1] 20.4 [6.0] 1.5	26.8 [7.9] 18.9 [5.5] 1.5	26.5 [7.8] 24.0 [7.0] 1.5	26.0 [7.6] 23.0 [6.7] 1.5	25.3 [7.4] 21.3 [6.2] 1.5
	85 [29.4]	Total BTUH [kW] Sens BTUH [kW] Power	29.0 [8.5] 17.6 [5.2] 1.6	28.5 [8.3] 16.8 [4.9] 1.6	27.7 [8.1] 15.6 [4.6] 1.6	27.1 [8.0] 20.8 [6.1] 1.6	26.7 [7.8] 19.9 [5.8] 1.6	25.9 [7.6] 18.4 [5.4] 1.6	25.5 [7.5] 23.5 [6.9] 1.6	25.1 [7.3] 22.4 [6.6] 1.6	24.4 [7.1] 20.8 [6.1] 1.6
	90 [32.2]	Total BTUH [kW] Sens BTUH [kW] Power	28.0 [8.2] 17.0 [5.0] 1.7	27.5 [8.1] 16.3 [4.8] 1.7	26.7 [7.8] 15.1 [4.4] 1.7	26.1 [7.7] 20.2 [5.9] 1.7	25.7 [7.5] 19.3 [5.7] 1.7	25.0 [7.3] 17.9 [5.3] 1.7	24.5 [7.2] 22.9 [6.7] 1.7	24.1 [7.1] 21.9 [6.4] 1.7	23.4 [6.9] 20.3 [5.9] 1.7
	95 [35]	Total BTUH [kW] Sens BTUH [kW] Power	27.0 [7.9] 16.5 [4.8] 1.9	26.5 [7.8] 15.7 [4.6] 1.8	25.7 [7.5] 14.6 [4.3] 1.8	25.1 [7.4] 19.7 [5.8] 1.8	24.7 [7.2] 18.8 [5.5] 1.8	24.0 [7.0] 17.4 [5.1] 1.8	23.5 [6.9] 22.3 [6.5] 1.8	23.1 [6.8] 21.3 [6.2] 1.8	22.4 [6.6] 19.8 [5.8] 1.8
	100 [37.8]	Total BTUH [kW] Sens BTUH [kW] Power	25.9 [7.6] 15.9 [4.6] 2.0	25.5 [7.5] 15.2 [4.4] 2.0	24.8 [7.3] 14.1 [4.1] 1.9	24.1 [7.1] 19.1 [5.6] 2.0	23.7 [6.9] 18.2 [5.3] 2.0	23.0 [6.7] 16.9 [5.0] 1.9	22.5 [6.6] 21.7 [6.4] 2.0	22.1 [6.5] 20.8 [6.1] 1.9	21.5 [6.3] 19.2 [5.6] 1.9
	105 [40.6]	Total BTUH [kW] Sens BTUH [kW] Power	24.9 [7.3] 15.3 [4.5] 2.1	24.5 [7.2] 14.6 [4.3] 2.1	23.8 [7.0] 13.5 [4.0] 2.1	23.1 [6.8] 18.5 [5.4] 2.1	22.6 [6.6] 17.7 [5.2] 2.1	22.0 [6.4] 16.4 [4.8] 2.1	21.4 [6.3] 21.1 [6.2] 2.1	21.1 [6.2] 20.2 [5.9] 2.1	20.5 [6.0] 18.7 [5.5] 2.0
	110 [43.3]	Total BTUH [kW] Sens BTUH [kW] Power	23.8 [7.0] 14.7 [4.3] 2.3	23.4 [6.9] 14.0 [4.1] 2.2	22.7 [6.7] 13.0 [3.8] 2.2	22.0 [6.4] 17.9 [5.2] 2.2	21.6 [6.3] 17.1 [5.0] 2.2	21.0 [6.1] 15.8 [4.6] 2.2	20.4 [6.0] 20.4 [6.0] 2.2	20.0 [5.9] 19.6 [5.7] 2.2	19.4 [5.7] 18.2 [5.3] 2.2
	115 [46.1]	Total BTUH [kW] Sens BTUH [kW] Power	22.8 [6.7] 14.1 [4.1] 2.4	22.3 [6.5] 13.4 [3.9] 2.4	21.7 [6.4] 12.5 [3.6] 2.3	20.9 [6.1] 17.3 [5.1] 2.4	20.5 [6.0] 16.5 [4.8] 2.4	19.9 [5.8] 15.3 [4.5] 2.3	19.3 [5.7] 19.3 [5.7] 2.4	18.9 [5.6] 18.9 [5.6] 2.4	18.4 [5.4] 17.6 [5.2] 2.3
	120 [48.9]	Total BTUH [kW] Sens BTUH [kW] Power	21.7 [6.3] 13.4 [3.9] 2.6	21.3 [6.2] 12.8 [3.8] 2.5	20.7 [6.1] 11.9 [3.5] 2.5	19.8 [5.8] 16.6 [4.9] 2.5	19.5 [5.7] 15.9 [4.7] 2.5	18.9 [5.5] 14.7 [4.3] 2.5	18.2 [5.3] 18.2 [5.3] 2.5	17.9 [5.2] 17.9 [5.2] 2.5	17.4 [5.1] 17.1 [5.0] 2.5
	125 [51.7]	Total BTUH [kW] Sens BTUH [kW] Power	20.5 [6.0] 12.8 [3.8] 2.7	20.2 [5.9] 12.2 [3.6] 2.7	19.6 [5.7] 11.3 [3.3] 2.7	18.7 [5.5] 16.0 [4.7] 2.7	18.4 [5.4] 15.3 [4.5] 2.7	17.8 [5.2] 14.2 [4.2] 2.7	17.1 [5.0] 17.1 [5.0] 2.7	16.8 [4.9] 16.8 [4.9] 2.7	16.3 [4.8] 16.3 [4.8] 2.6

DR —Depression ratio
 dbE —Entering air dry bulb
 wbE—Entering air wet bulb

Total —Total capacity x 1000 BTUH
 Sens —Sensible capacity x 1000 BTUH
 Power —KW input

NOTES: ① When the entering air dry bulb is other than 80°F [27°C], adjust the sensible capacity from the table by adding $[1.10 \times \text{CFM} \times (1 - \text{DR}) \times (\text{dbE} - 80)]$.

[] Designates Metric Conversions



GROSS SYSTEMS PERFORMANCE DATA—RGEA15030A

		ENTERING INDOOR AIR @ 80°F [26.7°C] dbE ①									
wbE		71°F [21.7°C]			67°F [19.4°C]			63°F [17.2°C]			
CFM [L/s]		1070 [505]	975 [460]	830 [392]	1070 [505]	975 [460]	830 [392]	1070 [505]	975 [460]	830 [392]	
DR ①		0.16	0.14	0.1	0.16	0.14	0.1	0.16	0.14	0.1	
OUTDOOR DRY BULB TEMPERATURE °F [°C]	75 [23.9]	Total BTUH [kW] Sens BTUH [kW] Power	36.8 [10.8] 21.5 [6.3] 1.7	36.1 [10.6] 20.5 [6.0] 1.7	35.2 [10.3] 19.1 [5.6] 1.6	34.3 [10.1] 25.1 [7.4] 1.7	33.7 [9.9] 24.0 [7.0] 1.6	32.8 [9.6] 22.4 [6.6] 1.6	32.4 [9.5] 28.3 [8.3] 1.6	31.8 [9.3] 27.1 [7.9] 1.6	31.0 [9.1] 25.2 [7.4] 1.6
	80 [26.7]	Total BTUH [kW] Sens BTUH [kW] Power	35.7 [10.5] 21.0 [6.1] 1.8	35.1 [10.3] 20.1 [5.9] 1.7	34.2 [10.0] 18.7 [5.5] 1.7	33.3 [9.7] 24.7 [7.2] 1.7	32.7 [9.6] 23.6 [6.9] 1.7	31.8 [9.3] 21.9 [6.4] 1.7	31.3 [9.2] 27.8 [8.2] 1.7	30.8 [9.0] 26.6 [7.8] 1.7	30.0 [8.8] 24.8 [7.3] 1.7
	85 [29.4]	Total BTUH [kW] Sens BTUH [kW] Power	34.7 [10.2] 20.5 [6.0] 1.9	34.1 [10.0] 19.6 [5.7] 1.8	33.2 [9.7] 18.2 [5.3] 1.8	32.2 [9.4] 24.2 [7.1] 1.8	31.7 [9.3] 23.1 [6.8] 1.8	30.8 [9.0] 21.5 [6.3] 1.8	30.3 [8.9] 27.4 [8.0] 1.8	29.8 [8.7] 26.2 [7.7] 1.8	29.0 [8.5] 24.3 [7.1] 1.8
	90 [32.2]	Total BTUH [kW] Sens BTUH [kW] Power	33.7 [9.9] 20.0 [5.9] 2.0	33.1 [9.7] 19.1 [5.6] 1.9	32.2 [9.4] 17.8 [5.2] 1.9	31.2 [9.1] 23.6 [6.9] 1.9	30.6 [9.0] 22.6 [6.6] 1.9	29.8 [8.7] 21.0 [6.2] 1.9	29.2 [8.6] 26.8 [7.9] 1.9	28.7 [8.4] 25.7 [7.5] 1.9	28.0 [8.2] 23.9 [7.0] 1.9
	95 [35]	Total BTUH [kW] Sens BTUH [kW] Power	32.6 [9.5] 19.4 [5.7] 2.1	32.0 [9.4] 18.6 [5.4] 2.1	31.2 [9.1] 17.3 [5.1] 2.0	30.1 [8.8] 23.1 [6.8] 2.1	29.6 [8.7] 22.1 [6.5] 2.0	28.8 [8.4] 20.5 [6.0] 2.0	28.2 [8.3] 26.3 [7.7] 2.0	27.7 [8.1] 25.1 [7.4] 2.0	26.9 [7.9] 23.4 [6.9] 2.0
	100 [37.8]	Total BTUH [kW] Sens BTUH [kW] Power	31.5 [9.2] 18.8 [5.5] 2.2	31.0 [9.1] 18.0 [5.3] 2.2	30.1 [8.8] 16.8 [4.9] 2.1	29.0 [8.5] 22.5 [6.6] 2.2	28.5 [8.4] 21.5 [6.3] 2.2	27.7 [8.1] 20.0 [5.9] 2.1	27.1 [7.9] 25.7 [7.5] 2.2	26.6 [7.8] 24.6 [7.2] 2.1	25.9 [7.6] 22.9 [6.7] 2.1
	105 [40.6]	Total BTUH [kW] Sens BTUH [kW] Power	30.4 [8.9] 18.2 [5.3] 2.3	29.9 [8.8] 17.4 [5.1] 2.3	29.1 [8.5] 16.2 [4.8] 2.3	27.9 [8.2] 21.9 [6.4] 2.3	27.4 [8.0] 20.9 [6.1] 2.3	26.7 [7.8] 19.5 [5.7] 2.3	26.0 [7.6] 25.1 [7.4] 2.3	25.6 [7.5] 24.0 [7.0] 2.3	24.9 [7.3] 22.3 [6.5] 2.2
	110 [43.3]	Total BTUH [kW] Sens BTUH [kW] Power	29.3 [8.6] 17.6 [5.2] 2.5	28.8 [8.4] 16.8 [4.9] 2.4	28.0 [8.2] 15.7 [4.6] 2.4	26.8 [7.9] 21.3 [6.2] 2.4	26.4 [7.7] 20.3 [6.0] 2.4	25.6 [7.5] 18.9 [5.5] 2.4	24.9 [7.3] 24.4 [7.2] 2.4	24.5 [7.2] 23.4 [6.9] 2.4	23.8 [7.0] 21.8 [6.4] 2.4
	115 [46.1]	Total BTUH [kW] Sens BTUH [kW] Power	28.2 [8.3] 16.9 [5.0] 2.6	27.7 [8.1] 16.2 [4.7] 2.6	27.0 [7.9] 15.1 [4.4] 2.5	25.7 [7.5] 20.6 [6.0] 2.6	25.3 [7.4] 19.7 [5.8] 2.6	24.6 [7.2] 18.3 [5.4] 2.5	23.8 [7.0] 23.8 [7.0] 2.6	23.4 [6.8] 22.7 [6.7] 2.6	22.7 [6.7] 21.2 [6.2] 2.5
	120 [48.9]	Total BTUH [kW] Sens BTUH [kW] Power	27.1 [7.9] 16.2 [4.8] 2.8	26.6 [7.8] 15.5 [4.5] 2.7	25.9 [7.6] 14.4 [4.2] 2.7	24.6 [7.2] 19.9 [5.8] 2.7	24.2 [7.1] 19.0 [5.6] 2.7	23.5 [6.9] 17.7 [5.2] 2.7	22.7 [6.6] 22.7 [6.6] 2.7	22.3 [6.5] 22.1 [6.5] 2.7	21.7 [6.3] 20.5 [6.0] 2.7
125 [51.7]	Total BTUH [kW] Sens BTUH [kW] Power	25.9 [7.6] 15.5 [4.5] 2.9	25.5 [7.5] 14.8 [4.3] 2.9	24.8 [7.3] 13.8 [4.0] 2.8	23.4 [6.9] 19.2 [5.6] 2.9	23.0 [6.7] 18.3 [5.4] 2.9	22.4 [6.6] 17.1 [5.0] 2.8	21.5 [6.3] 21.5 [6.3] 2.9	21.1 [6.2] 21.1 [6.2] 2.9	20.6 [6.0] 19.9 [5.8] 2.8	

DR —Depression ratio
dbE —Entering air dry bulb
wbE—Entering air wet bulb

Total —Total capacity x 1000 BTUH
Sens —Sensible capacity x 1000 BTUH
Power —KW input

NOTES: ① When the entering air dry bulb is other than 80°F [27°C], adjust the sensible capacity from the table by adding [1.10 x CFM x (1 - DR) x (dbE - 80)].

[] Designates Metric Conversions





GROSS SYSTEMS PERFORMANCE DATA – RGEA15036A

		ENTERING INDOOR AIR @ 80°F [26.7°C] dbE ①									
wbE		71°F [21.7°C]			67°F [19.4°C]			63°F [17.2°C]			
CFM [L/s]		1320 [623]	1200 [566]	1020 [481]	1320 [623]	1200 [566]	1020 [481]	1320 [623]	1200 [566]	1020 [481]	
DR ①		0.19	0.18	0.15	0.19	0.18	0.15	0.19	0.18	0.15	
OUTDOOR DRY BULB TEMPERATURE °F [°C]	75 [23.9]	Total BTUH [kW] Sens BTUH [kW] Power	44.8 [13.1] 26.2 [7.7] 2.0	44.0 [12.9] 25.0 [7.3] 2.0	42.8 [12.5] 23.3 [6.8] 2.0	41.9 [12.3] 30.6 [9.0] 2.0	41.1 [12.1] 29.2 [8.6] 2.0	40.0 [11.7] 27.2 [8.0] 2.0	38.9 [11.4] 33.9 [9.9] 2.0	38.2 [11.2] 32.4 [9.5] 2.0	37.2 [10.9] 30.1 [8.8] 2.0
	80 [26.7]	Total BTUH [kW] Sens BTUH [kW] Power	43.5 [12.8] 25.4 [7.5] 2.1	42.7 [12.5] 24.3 [7.1] 2.1	41.6 [12.2] 22.6 [6.6] 2.1	40.6 [11.9] 29.9 [8.7] 2.1	39.9 [11.7] 28.5 [8.4] 2.1	38.8 [11.4] 26.5 [7.8] 2.1	37.6 [11.0] 33.2 [9.7] 2.1	36.9 [10.8] 31.7 [9.3] 2.1	35.9 [10.5] 29.5 [8.6] 2.1
	85 [29.4]	Total BTUH [kW] Sens BTUH [kW] Power	42.2 [12.4] 24.7 [7.2] 2.3	41.4 [12.1] 23.6 [6.9] 2.2	40.3 [11.8] 21.9 [6.4] 2.2	39.3 [11.5] 29.1 [8.5] 2.2	38.6 [11.3] 27.8 [8.1] 2.2	37.5 [11.0] 25.9 [7.6] 2.2	36.3 [10.6] 32.4 [9.5] 2.2	35.6 [10.4] 31.0 [9.1] 2.2	34.6 [10.2] 28.8 [8.4] 2.2
	90 [32.2]	Total BTUH [kW] Sens BTUH [kW] Power	40.9 [12.0] 23.9 [7.0] 2.4	40.1 [11.8] 22.9 [6.7] 2.4	39.0 [11.4] 21.3 [6.2] 2.3	37.9 [11.1] 28.3 [8.3] 2.4	37.2 [10.9] 27.1 [7.9] 2.4	36.2 [10.6] 25.2 [7.4] 2.3	34.9 [10.2] 31.6 [9.3] 2.4	34.3 [10.1] 30.2 [8.9] 2.3	33.4 [9.8] 28.1 [8.2] 2.3
	95 [35]	Total BTUH [kW] Sens BTUH [kW] Power	39.5 [11.6] 23.1 [6.8] 2.5	38.8 [11.4] 22.1 [6.5] 2.5	37.7 [11.1] 20.6 [6.0] 2.5	36.6 [10.7] 27.5 [8.1] 2.5	35.9 [10.5] 26.3 [7.7] 2.5	34.9 [10.2] 24.5 [7.2] 2.5	33.6 [9.8] 30.9 [9.0] 2.5	33.0 [9.7] 29.5 [8.6] 2.5	32.1 [9.4] 27.4 [8.0] 2.5
	100 [37.8]	Total BTUH [kW] Sens BTUH [kW] Power	38.1 [11.2] 22.3 [6.5] 2.7	37.5 [11.0] 21.3 [6.3] 2.7	36.4 [10.7] 19.9 [5.8] 2.6	35.2 [10.3] 26.7 [7.8] 2.7	34.6 [10.1] 25.6 [7.5] 2.7	33.6 [9.9] 23.8 [7.0] 2.6	32.2 [9.4] 30.1 [8.8] 2.7	31.6 [9.3] 28.7 [8.4] 2.6	30.8 [9.0] 26.7 [7.8] 2.6
	105 [40.6]	Total BTUH [kW] Sens BTUH [kW] Power	36.8 [10.8] 21.5 [6.3] 2.9	36.1 [10.6] 20.6 [6.0] 2.8	35.1 [10.3] 19.1 [5.6] 2.8	33.8 [9.9] 25.9 [7.6] 2.8	33.2 [9.7] 24.8 [7.3] 2.8	32.3 [9.5] 23.0 [6.7] 2.8	30.8 [9.0] 29.2 [8.6] 2.8	30.3 [8.9] 27.9 [8.2] 2.8	29.5 [8.6] 26.0 [7.6] 2.8
	110 [43.3]	Total BTUH [kW] Sens BTUH [kW] Power	35.4 [10.4] 20.7 [6.1] 3.0	34.7 [10.2] 19.8 [5.8] 3.0	33.8 [9.9] 18.4 [5.4] 3.0	32.4 [9.5] 25.1 [7.4] 3.0	31.9 [9.3] 24.0 [7.0] 3.0	31.0 [9.1] 22.3 [6.5] 3.0	29.4 [8.6] 28.4 [8.3] 3.0	28.9 [8.5] 27.1 [8.0] 3.0	28.1 [8.2] 25.2 [7.4] 2.9
	115 [46.1]	Total BTUH [kW] Sens BTUH [kW] Power	34.0 [10.0] 19.8 [5.8] 3.2	33.4 [9.8] 18.9 [5.5] 3.2	32.4 [9.5] 17.6 [5.2] 3.2	31.0 [9.1] 24.2 [7.1] 3.2	30.5 [8.9] 23.1 [6.8] 3.2	29.6 [8.7] 21.5 [6.3] 3.1	28.0 [8.2] 27.5 [8.1] 3.2	27.5 [8.1] 26.3 [7.7] 3.2	26.8 [7.8] 24.5 [7.2] 3.1
	120 [48.9]	Total BTUH [kW] Sens BTUH [kW] Power	32.5 [9.5] 18.9 [5.6] 3.4	32.0 [9.4] 18.1 [5.3] 3.4	31.1 [9.1] 16.8 [4.9] 3.4	29.6 [8.7] 23.3 [6.8] 3.4	29.1 [8.5] 22.3 [6.5] 3.4	28.3 [8.3] 20.7 [6.1] 3.3	26.6 [7.8] 26.6 [7.8] 3.4	26.1 [7.7] 25.5 [7.5] 3.4	25.4 [7.4] 23.7 [6.9] 3.3
	125 [51.7]	Total BTUH [kW] Sens BTUH [kW] Power	31.1 [9.1] 18.0 [5.3] 3.6	30.5 [9.0] 17.2 [5.1] 3.6	29.7 [8.7] 16.0 [4.7] 3.6	28.2 [8.3] 22.4 [6.6] 3.6	27.7 [8.1] 21.4 [6.3] 3.6	26.9 [7.9] 19.9 [5.8] 3.6	25.2 [7.4] 25.2 [7.4] 3.6	24.7 [7.2] 24.6 [7.2] 3.6	24.1 [7.0] 22.9 [6.7] 3.5

DR —Depression ratio
dbE —Entering air dry bulb
wbE—Entering air wet bulb

Total —Total capacity x 1000 BTUH
Sens —Sensible capacity x 1000 BTUH
Power —KW input

NOTES: ① When the entering air dry bulb is other than 80°F [27°C], adjust the sensible capacity from the table by adding $[1.10 \times \text{CFM} \times (1 - \text{DR}) \times (\text{dbE} - 80)]$.

[] Designates Metric Conversions



GROSS SYSTEMS PERFORMANCE DATA—RGEA15042A

wbE		ENTERING INDOOR AIR @ 80°F [26.7°C] dbE ①									
		71°F [21.7°C]			67°F [19.4°C]			63°F [17.2°C]			
CFM [L/s]		1430 [675]	1300 [614]	1100 [519]	1430 [675]	1300 [614]	1100 [519]	1430 [675]	1300 [614]	1100 [519]	
DR ①		0.17	0.16	0.13	0.17	0.16	0.13	0.17	0.16	0.13	
OUTDOOR DRY BULB TEMPERATURE °F [°C]	75 [23.9]	Total BTUH [kW] Sens BTUH [kW] Power	50.1 [14.7] 28.6 [8.4] 2.4	49.2 [14.4] 27.3 [8.0] 2.3	47.8 [14.0] 25.3 [7.4] 2.3	47.2 [13.8] 33.9 [9.9] 2.4	46.4 [13.6] 32.4 [9.5] 2.3	45.1 [13.2] 30.0 [8.8] 2.3	44.7 [13.1] 38.8 [11.4] 2.3	43.9 [12.9] 37.1 [10.9] 2.3	42.7 [12.5] 34.4 [10.1] 2.3
	80 [26.7]	Total BTUH [kW] Sens BTUH [kW] Power	48.8 [14.3] 27.9 [8.2] 2.5	47.9 [14.0] 26.7 [7.8] 2.5	46.6 [13.6] 24.8 [7.3] 2.5	45.9 [13.5] 33.2 [9.7] 2.5	45.1 [13.2] 31.8 [9.3] 2.5	43.8 [12.8] 29.5 [8.6] 2.4	43.4 [12.7] 38.1 [11.2] 2.5	42.6 [12.5] 36.4 [10.7] 2.5	41.5 [12.1] 33.8 [9.9] 2.4
	85 [29.4]	Total BTUH [kW] Sens BTUH [kW] Power	47.4 [13.9] 27.2 [8.0] 2.7	46.6 [13.7] 26.0 [7.6] 2.6	45.3 [13.3] 24.2 [7.1] 2.6	44.6 [13.1] 32.6 [9.5] 2.6	43.8 [12.8] 31.1 [9.1] 2.6	42.6 [12.5] 28.9 [8.5] 2.6	42.1 [12.3] 37.5 [11.0] 2.6	41.3 [12.1] 35.8 [10.5] 2.6	40.2 [11.8] 33.2 [9.7] 2.6
	90 [32.2]	Total BTUH [kW] Sens BTUH [kW] Power	46.1 [13.5] 26.5 [7.8] 2.8	45.3 [13.3] 25.3 [7.4] 2.8	44.0 [12.9] 23.5 [6.9] 2.8	43.2 [12.7] 31.8 [9.3] 2.8	42.5 [12.4] 30.4 [8.9] 2.8	41.3 [12.1] 28.2 [8.3] 2.7	40.7 [11.9] 36.8 [10.8] 2.8	40.0 [11.7] 35.1 [10.3] 2.8	38.9 [11.4] 32.6 [9.6] 2.7
	95 [35]	Total BTUH [kW] Sens BTUH [kW] Power	44.7 [13.1] 25.8 [7.6] 3.0	43.9 [12.9] 24.6 [7.2] 3.0	42.7 [12.5] 22.9 [6.7] 2.9	41.8 [12.3] 31.1 [9.1] 3.0	41.1 [12.0] 29.7 [8.7] 3.0	39.9 [11.7] 27.6 [8.1] 2.9	39.3 [11.5] 36.0 [10.5] 3.0	38.6 [11.3] 34.4 [10.1] 2.9	37.5 [11.0] 31.9 [9.4] 2.9
	100 [37.8]	Total BTUH [kW] Sens BTUH [kW] Power	43.3 [12.7] 25.0 [7.3] 3.2	42.5 [12.4] 23.9 [7.0] 3.2	41.3 [12.1] 22.1 [6.5] 3.1	40.4 [11.8] 30.3 [8.9] 3.2	39.7 [11.6] 28.9 [8.5] 3.1	38.6 [11.3] 26.9 [7.9] 3.1	37.9 [11.1] 35.2 [10.3] 3.2	37.2 [10.9] 33.6 [9.9] 3.1	36.2 [10.6] 31.2 [9.1] 3.1
	105 [40.6]	Total BTUH [kW] Sens BTUH [kW] Power	41.8 [12.2] 24.1 [7.1] 3.4	41.0 [12.0] 23.1 [6.8] 3.4	39.9 [11.7] 21.4 [6.3] 3.3	38.9 [11.4] 29.4 [8.6] 3.4	38.2 [11.2] 28.1 [8.2] 3.3	37.2 [10.9] 26.1 [7.7] 3.3	36.4 [10.7] 34.4 [10.1] 3.4	35.8 [10.5] 32.8 [9.6] 3.3	34.8 [10.2] 30.5 [8.9] 3.3
	110 [43.3]	Total BTUH [kW] Sens BTUH [kW] Power	40.3 [11.8] 23.3 [6.8] 3.6	39.6 [11.6] 22.2 [6.5] 3.6	38.5 [11.3] 20.6 [6.0] 3.5	37.4 [11.0] 28.6 [8.4] 3.6	36.8 [10.8] 27.3 [8.0] 3.5	35.7 [10.5] 25.3 [7.4] 3.5	34.9 [10.2] 33.5 [9.8] 3.6	34.3 [10.1] 32.0 [9.4] 3.5	33.3 [9.8] 29.7 [8.7] 3.5
	115 [46.1]	Total BTUH [kW] Sens BTUH [kW] Power	38.7 [11.4] 22.3 [6.5] 3.8	38.0 [11.1] 21.4 [6.3] 3.8	37.0 [10.8] 19.8 [5.8] 3.7	35.9 [10.5] 27.7 [8.1] 3.8	35.3 [10.3] 26.4 [7.7] 3.8	34.3 [10.0] 24.5 [7.2] 3.7	33.4 [9.8] 32.6 [9.5] 3.8	32.8 [9.6] 31.1 [9.1] 3.7	31.9 [9.3] 28.9 [8.5] 3.7
	120 [48.9]	Total BTUH [kW] Sens BTUH [kW] Power	37.2 [10.9] 21.4 [6.3] 4.0	36.5 [10.7] 20.4 [6.0] 4.0	35.5 [10.4] 19.0 [5.6] 3.9	34.3 [10.1] 26.7 [7.8] 4.0	33.7 [9.9] 25.5 [7.5] 4.0	32.8 [9.6] 23.7 [6.9] 3.9	31.8 [9.3] 31.6 [9.3] 4.0	31.2 [9.2] 30.2 [8.9] 4.0	30.4 [8.9] 28.0 [8.2] 3.9
	125 [51.7]	Total BTUH [kW] Sens BTUH [kW] Power	35.6 [10.4] 20.4 [6.0] 4.3	34.9 [10.2] 19.5 [5.7] 4.2	33.9 [9.9] 18.1 [5.3] 4.2	32.7 [9.6] 25.7 [7.5] 4.3	32.1 [9.4] 24.6 [7.2] 4.2	31.2 [9.2] 22.8 [6.7] 4.2	30.2 [8.8] 30.2 [8.8] 4.2	29.7 [8.7] 29.3 [8.6] 4.2	28.8 [8.4] 27.2 [8.0] 4.1

DR —Depression ratio
dbE —Entering air dry bulb
wbE—Entering air wet bulb

Total —Total capacity x 1000 BTUH
Sens —Sensible capacity x 1000 BTUH
Power —KW input

NOTES: ① When the entering air dry bulb is other than 80°F [27°C], adjust the sensible capacity from the table by adding [1.10 x CFM x (1 - DR) x (dbE - 80)].

[] Designates Metric Conversions





GROSS SYSTEMS PERFORMANCE DATA – RGEA15048A

		ENTERING INDOOR AIR @ 80°F [26.7°C] dbE ①									
		71°F [21.7°C]			67°F [19.4°C]			63°F [17.2°C]			
wbE		1700 [802]	1550 [732]	1320 [623]	1700 [802]	1550 [732]	1320 [623]	1700 [802]	1550 [732]	1320 [623]	
CFM [L/s]											
DR ①		0.19	0.18	0.15	0.19	0.18	0.15	0.19	0.18	0.15	
OUTDOOR DRY BULB TEMPERATURE °F [°C]	75 [23.9]	Total BTUH [kW] Sens BTUH [kW] Power	58.3 [17.1] 33.2 [9.7] 2.7	57.3 [16.8] 31.8 [9.3] 2.6	55.8 [16.3] 29.6 [8.7] 2.6	54.6 [16.0] 39.2 [11.5] 2.7	53.7 [15.7] 37.5 [11.0] 2.6	52.2 [15.3] 34.9 [10.2] 2.6	51.6 [15.1] 44.7 [13.1] 2.6	50.7 [14.9] 42.8 [12.5] 2.6	49.3 [14.5] 39.8 [11.7] 2.6
	80 [26.7]	Total BTUH [kW] Sens BTUH [kW] Power	56.8 [16.7] 32.5 [9.5] 2.8	55.8 [16.4] 31.1 [9.1] 2.8	54.3 [15.9] 28.9 [8.5] 2.8	53.1 [15.6] 38.5 [11.3] 2.8	52.2 [15.3] 36.8 [10.8] 2.8	50.8 [14.9] 34.3 [10.0] 2.7	50.1 [14.7] 44.0 [12.9] 2.8	49.2 [14.4] 42.1 [12.3] 2.8	47.9 [14.0] 39.2 [11.5] 2.7
	85 [29.4]	Total BTUH [kW] Sens BTUH [kW] Power	55.3 [16.2] 31.7 [9.3] 3.0	54.3 [15.9] 30.3 [8.9] 2.9	52.8 [15.5] 28.2 [8.3] 2.9	51.5 [15.1] 37.7 [11.0] 2.9	50.6 [14.8] 36.0 [10.6] 2.9	49.3 [14.4] 33.6 [9.8] 2.9	48.5 [14.2] 43.2 [12.7] 2.9	47.7 [14.0] 41.3 [12.1] 2.9	46.4 [13.6] 38.4 [11.3] 2.9
	90 [32.2]	Total BTUH [kW] Sens BTUH [kW] Power	53.6 [15.7] 30.8 [9.0] 3.1	52.7 [15.4] 29.5 [8.6] 3.1	51.3 [15.0] 27.4 [8.0] 3.1	49.9 [14.6] 36.8 [10.8] 3.1	49.0 [14.4] 35.2 [10.3] 3.1	47.7 [14.0] 32.8 [9.6] 3.0	46.9 [13.7] 42.3 [12.4] 3.1	46.1 [13.5] 40.5 [11.9] 3.1	44.8 [13.1] 37.7 [11.0] 3.0
	95 [35]	Total BTUH [kW] Sens BTUH [kW] Power	51.9 [15.2] 29.9 [8.8] 3.3	51.0 [14.9] 28.6 [8.4] 3.3	49.6 [14.5] 26.6 [7.8] 3.2	48.2 [14.1] 35.9 [10.5] 3.3	47.3 [13.9] 34.3 [10.1] 3.3	46.1 [13.5] 32.0 [9.4] 3.2	45.2 [13.2] 41.4 [12.1] 3.3	44.4 [13.0] 39.6 [11.6] 3.3	43.2 [12.7] 36.8 [10.8] 3.2
	100 [37.8]	Total BTUH [kW] Sens BTUH [kW] Power	50.1 [14.7] 28.9 [8.5] 3.5	49.2 [14.4] 27.6 [8.1] 3.5	47.9 [14.0] 25.7 [7.5] 3.4	46.4 [13.6] 34.9 [10.2] 3.5	45.6 [13.4] 33.4 [9.8] 3.5	44.3 [13.0] 31.1 [9.1] 3.4	43.4 [12.7] 40.4 [11.8] 3.5	42.6 [12.5] 38.6 [11.3] 3.4	41.5 [12.2] 36.0 [10.5] 3.4
	105 [40.6]	Total BTUH [kW] Sens BTUH [kW] Power	48.2 [14.1] 27.8 [8.2] 3.7	47.4 [13.9] 26.6 [7.8] 3.7	46.1 [13.5] 24.8 [7.3] 3.6	44.5 [13.0] 33.8 [9.9] 3.7	43.7 [12.8] 32.4 [9.5] 3.7	42.6 [12.5] 30.1 [8.8] 3.6	41.5 [12.2] 39.3 [11.5] 3.7	40.8 [12.0] 37.6 [11.0] 3.7	39.7 [11.6] 35.0 [10.3] 3.6
	110 [43.3]	Total BTUH [kW] Sens BTUH [kW] Power	46.3 [13.6] 26.7 [7.8] 3.9	45.5 [13.3] 25.6 [7.5] 3.9	44.3 [13.0] 23.8 [7.0] 3.9	42.6 [12.5] 32.7 [9.6] 3.9	41.9 [12.3] 31.3 [9.2] 3.9	40.7 [11.9] 29.1 [8.5] 3.8	39.6 [11.6] 38.2 [11.2] 3.9	38.9 [11.4] 36.6 [10.7] 3.9	37.9 [11.1] 34.0 [10.0] 3.8
	115 [46.1]	Total BTUH [kW] Sens BTUH [kW] Power	44.3 [13.0] 25.5 [7.5] 4.2	43.5 [12.8] 24.4 [7.2] 4.2	42.4 [12.4] 22.7 [6.7] 4.1	40.6 [11.9] 31.6 [9.2] 4.2	39.9 [11.7] 30.2 [8.8] 4.1	38.8 [11.4] 28.1 [8.2] 4.1	37.6 [11.0] 37.1 [10.9] 4.2	36.9 [10.8] 35.5 [10.4] 4.1	35.9 [10.5] 33.0 [9.7] 4.1
	120 [48.9]	Total BTUH [kW] Sens BTUH [kW] Power	42.2 [12.4] 24.3 [7.1] 4.4	41.5 [12.2] 23.3 [6.8] 4.4	40.4 [11.8] 21.7 [6.3] 4.3	38.5 [11.3] 30.3 [8.9] 4.4	37.9 [11.1] 29.0 [8.5] 4.4	36.8 [10.8] 27.0 [7.9] 4.3	35.5 [10.4] 35.5 [10.4] 4.4	34.9 [10.2] 34.3 [10.0] 4.4	34.0 [10.0] 31.9 [9.3] 4.3
	125 [51.7]	Total BTUH [kW] Sens BTUH [kW] Power	40.1 [11.8] 23.0 [6.7] 4.7	39.4 [11.5] 22.0 [6.5] 4.7	38.3 [11.2] 20.5 [6.0] 4.6	36.4 [10.7] 29.0 [8.5] 4.7	35.7 [10.5] 27.8 [8.1] 4.6	34.8 [10.2] 25.9 [7.6] 4.6	33.4 [9.8] 33.4 [9.8] 4.7	32.8 [9.6] 32.8 [9.6] 4.6	31.9 [9.4] 30.8 [9.0] 4.6

DR —Depression ratio
dbE —Entering air dry bulb
wbE—Entering air wet bulb

Total —Total capacity x 1000 BTUH
Sens —Sensible capacity x 1000 BTUH
Power —KW input

NOTES: ① When the entering air dry bulb is other than 80°F [27°C], adjust the sensible capacity from the table by adding [1.10 x CFM x (1 – DR) x (dbE – 80)].

[] Designates Metric Conversions



GROSS SYSTEMS PERFORMANCE DATA— RGEA15060A

		ENTERING INDOOR AIR @ 80°F [26.7°C] dbE ①									
wbE		71°F [21.7°C]			67°F [19.4°C]			63°F [17.2°C]			
CFM [L/s]		2040 [963]	1850 [873]	1570 [741]	2040 [963]	1850 [873]	1570 [741]	2040 [963]	1850 [873]	1570 [741]	
DR ①		0.15	0.14	0.11	0.15	0.14	0.11	0.15	0.14	0.11	
OUTDOOR DRY BULB TEMPERATURE °F [°C]	75 [23.9]	Total BTUH [kW] Sens BTUH [kW] Power	73.0 [21.4] 42.4 [12.4] 3.6	71.7 [21.0] 40.5 [11.9] 3.6	69.7 [20.4] 37.6 [11.0] 3.5	69.2 [20.3] 50.0 [14.6] 3.6	67.9 [19.9] 47.7 [14.0] 3.5	66.0 [19.3] 44.3 [13.0] 3.5	65.8 [19.3] 56.9 [16.7] 3.5	64.6 [18.9] 54.3 [15.9] 3.5	62.8 [18.4] 50.5 [14.8] 3.4
	80 [26.7]	Total BTUH [kW] Sens BTUH [kW] Power	70.9 [20.8] 41.3 [12.1] 3.8	69.6 [20.4] 39.4 [11.6] 3.7	67.7 [19.8] 36.6 [10.7] 3.7	67.1 [19.6] 48.8 [14.3] 3.7	65.8 [19.3] 46.6 [13.7] 3.7	64.0 [18.8] 43.3 [12.7] 3.6	63.7 [18.7] 55.8 [16.4] 3.7	62.5 [18.3] 53.2 [15.6] 3.7	60.8 [17.8] 49.5 [14.5] 3.6
	85 [29.4]	Total BTUH [kW] Sens BTUH [kW] Power	68.8 [20.2] 40.1 [11.8] 4.0	67.6 [19.8] 38.3 [11.2] 3.9	65.7 [19.3] 35.6 [10.4] 3.9	64.9 [19.0] 47.7 [14.0] 3.9	63.7 [18.7] 45.5 [13.3] 3.9	62.0 [18.2] 42.3 [12.4] 3.8	61.5 [18.0] 54.6 [16.0] 3.9	60.4 [17.7] 52.1 [15.3] 3.8	58.8 [17.2] 48.5 [14.2] 3.8
	90 [32.2]	Total BTUH [kW] Sens BTUH [kW] Power	66.7 [19.5] 38.9 [11.4] 4.2	65.4 [19.2] 37.2 [10.9] 4.1	63.6 [18.6] 34.5 [10.1] 4.1	62.8 [18.4] 46.5 [13.6] 4.1	61.6 [18.1] 44.3 [13.0] 4.1	59.9 [17.6] 41.2 [12.1] 4.0	59.4 [17.4] 53.4 [15.7] 4.1	58.3 [17.1] 51.0 [14.9] 4.0	56.7 [16.6] 47.4 [13.9] 4.0
	95 [35]	Total BTUH [kW] Sens BTUH [kW] Power	64.5 [18.9] 37.7 [11.0] 4.4	63.3 [18.5] 36.0 [10.5] 4.3	61.5 [18.0] 33.4 [9.8] 4.3	60.6 [17.7] 45.2 [13.3] 4.3	59.5 [17.4] 43.2 [12.6] 4.3	57.8 [16.9] 40.1 [11.8] 4.2	57.2 [16.8] 52.2 [15.3] 4.3	56.1 [16.5] 49.8 [14.6] 4.3	54.6 [16.0] 46.3 [13.6] 4.2
	100 [37.8]	Total BTUH [kW] Sens BTUH [kW] Power	62.2 [18.2] 36.4 [10.7] 4.6	61.1 [17.9] 34.7 [10.2] 4.6	59.4 [17.4] 32.3 [9.5] 4.5	58.3 [17.1] 43.9 [12.9] 4.6	57.3 [16.8] 41.9 [12.3] 4.5	55.7 [16.3] 39.0 [11.4] 4.5	55.0 [16.1] 50.9 [14.9] 4.5	54.0 [15.8] 48.6 [14.2] 4.5	52.5 [15.4] 45.1 [13.2] 4.4
	105 [40.6]	Total BTUH [kW] Sens BTUH [kW] Power	60.0 [17.6] 35.1 [10.3] 4.9	58.9 [17.3] 33.5 [9.8] 4.8	57.3 [16.8] 31.1 [9.1] 4.8	56.1 [16.4] 42.6 [12.5] 4.8	55.1 [16.1] 40.7 [11.9] 4.8	53.5 [15.7] 37.8 [11.1] 4.7	52.7 [15.4] 49.6 [14.5] 4.8	51.8 [15.2] 47.3 [13.9] 4.8	50.3 [14.7] 44.0 [12.9] 4.7
	110 [43.3]	Total BTUH [kW] Sens BTUH [kW] Power	57.7 [16.9] 33.7 [9.9] 5.2	56.6 [16.6] 32.2 [9.4] 5.1	55.1 [16.1] 29.9 [8.8] 5.0	53.8 [15.8] 41.2 [12.1] 5.1	52.8 [15.5] 39.3 [11.5] 5.1	51.4 [15.1] 36.6 [10.7] 5.0	50.4 [14.8] 48.2 [14.1] 5.1	49.5 [14.5] 46.0 [13.5] 5.0	48.1 [14.1] 42.7 [12.5] 5.0
	115 [46.1]	Total BTUH [kW] Sens BTUH [kW] Power	55.4 [16.2] 32.3 [9.5] 5.4	54.4 [15.9] 30.8 [9.0] 5.4	52.9 [15.5] 28.6 [8.4] 5.3	51.5 [15.1] 39.8 [11.7] 5.4	50.5 [14.8] 38.0 [11.1] 5.4	49.2 [14.4] 35.3 [10.3] 5.3	48.1 [14.1] 46.8 [13.7] 5.4	47.2 [13.8] 44.6 [13.1] 5.3	45.9 [13.5] 41.5 [12.2] 5.2
	120 [48.9]	Total BTUH [kW] Sens BTUH [kW] Power	53.0 [15.5] 30.8 [9.0] 5.8	52.1 [15.3] 29.4 [8.6] 5.7	50.6 [14.8] 27.3 [8.0] 5.6	49.1 [14.4] 38.4 [11.2] 5.7	48.2 [14.1] 36.6 [10.7] 5.7	46.9 [13.7] 34.0 [10.0] 5.6	45.8 [13.4] 45.3 [13.3] 5.7	44.9 [13.2] 43.2 [12.7] 5.6	43.7 [12.8] 40.2 [11.8] 5.5
	125 [51.7]	Total BTUH [kW] Sens BTUH [kW] Power	50.7 [14.8] 29.3 [8.6] 6.1	49.7 [14.6] 28.0 [8.2] 6.0	48.4 [14.2] 26.0 [7.6] 6.0	46.8 [13.7] 36.9 [10.8] 6.0	45.9 [13.5] 35.2 [10.3] 6.0	44.6 [13.1] 32.7 [9.6] 5.9	43.4 [12.7] 43.4 [12.7] 6.0	42.6 [12.5] 41.8 [12.3] 6.0	41.4 [12.1] 38.9 [11.4] 5.9

DR —Depression ratio
dbE —Entering air dry bulb
wbE —Entering air wet bulb

Total —Total capacity x 1000 BTUH
Sens —Sensible capacity x 1000 BTUH
Power —kW input

NOTES: ① When the entering air dry bulb is other than 80°F [27°C], adjust the sensible capacity from the table by adding [1.10 x CFM x (1 - DR) x (dbE - 80)].

[] Designates Metric Conversions



INDOOR AIRFLOW PERFORMANCE RGEA14 - 208 VOLTS



Air

Indoor Airflow Performance
RGEA14 Series

Nominal Cooling Capacity Tons [kW]	Blower Size/ Motor HP [W] & Motor Type	Nominal Heating Capacity BTU/HR [kW]	Motor Speed	External Static Pressure - Inches W.C. [kPa] (Side Discharge-Dry Coil)										
				0.1 [0.02]	0.2 [0.05]	0.3 [0.07]	0.4 [0.10]	0.5 [0.12]	0.6 [0.15]	0.7 [0.17]	0.8 [0.20]	0.9 [0.22]	1.0 [0.25]	
2.0 [7.03]	10 x 9 Blower 1/2 HP [372 W] ECM	60,000 [17.58]	Heat	CFM	766 [362]	773 [365]	771 [364]	770 [363]	768 [362]	757 [357]	751 [354]	742 [350]	726 [343]	715 [337]
				RPM	649	746	829	897	946	1000	1046	1088	1133	1170
				Watts	83	107	130	152	169	188	206	222	240	255
	Cool	CFM	891 [421]	902 [426]	910 [429]	906 [428]	912 [430]	906 [428]	903 [426]	891 [421]	876 [413]	868 [410]	852 [403]	844 [400]
		RPM	747	831	895	957	1017	1068	1111	1151	1186	1223	1256	1293
		Watts	123	152	176	200	225	247	268	288	302	321	341	363
2.5 [8.79]	10 x 9 Blower 1/2 HP [372 W] ECM	80,000 [23.44]	Heat	CFM	1189 [561]	1198 [565]	1203 [568]	1210 [571]	1212 [572]	1208 [570]	1193 [563]	1146 [541]	1072 [506]	
				RPM	894	964	1008	1084	1142	1187	1234	1285	1301	1310
				Watts	236	273	299	344	378	411	441	477	475	446
	Cool	CFM	891 [421]	902 [426]	910 [429]	906 [428]	912 [430]	906 [428]	903 [426]	891 [421]	876 [413]	868 [410]	852 [403]	
		RPM	747	831	895	957	1017	1068	1111	1151	1186	1223	1256	
		Watts	123	152	176	200	225	247	268	288	302	321	341	
2.5 [8.79]	10 x 9 Blower 1/2 HP [372 W] ECM	60,000 [17.58]	Heat	CFM	766 [362]	773 [365]	771 [364]	770 [363]	768 [362]	757 [357]	751 [354]	742 [350]	726 [343]	715 [337]
				RPM	649	746	829	897	946	1000	1046	1088	1133	1170
				Watts	83	107	130	152	169	188	206	222	240	255
	Cool	CFM	959 [453]	973 [459]	978 [462]	981 [463]	985 [465]	974 [460]	966 [456]	952 [449]	949 [448]	949 [448]	949 [448]	
		RPM	772	855	922	990	1052	1100	1142	1184	1219	1256	1293	
		Watts	141	172	200	231	259	282	304	326	343	363	383	
2.5 [8.79]	10 x 9 Blower 1/2 HP [372 W] ECM	80,000 [23.44]	Heat	CFM	1189 [561]	1198 [565]	1203 [568]	1210 [571]	1212 [572]	1208 [570]	1193 [563]	1146 [541]	1072 [506]	
				RPM	894	964	1008	1084	1142	1187	1234	1285	1301	1310
				Watts	236	273	299	344	378	411	441	477	475	446
	Cool	CFM	959 [453]	973 [459]	978 [462]	981 [463]	985 [465]	974 [460]	966 [456]	952 [449]	949 [448]	949 [448]	949 [448]	
		RPM	772	855	922	990	1052	1100	1142	1184	1219	1256	1293	
		Watts	141	172	200	231	259	282	304	326	343	363	383	

Notes: (1) Set 2 through 4 ton Cool to Tap 4 for AHRI rated performance. (2) Set 5 ton 2nd Stage Cool to Tap 4 for AHRI rated performance.

[J Designates Metric Conversions



INDOOR AIRFLOW PERFORMANCE RGEA14 - 208 VOLTS (continued)

Nominal Cooling Capacity Tons [kW]	Blower Size/Motor HP [W] & Motor Type	Nominal Heating Capacity Btu/hr [kW]	Motor Speed	External Static Pressure - Inches W.C. [kPa] (Side Discharge-Dry Coil)										
				0.1 [.02]	0.2 [.05]	0.3 [.07]	0.4 [.10]	0.5 [.12]	0.6 [.15]	0.7 [.17]	0.8 [.20]	0.9 [.22]	1.0 [.25]	
3.0 [10.55]	10 x 9 Blower 1/2 HP [372 W] ECM	60,000 [17.58]	Heat	CFM	766 [362]	773 [365]	771 [364]	770 [363]	768 [362]	757 [357]	751 [354]	742 [350]	726 [343]	715 [337]
				RPM	649	746	829	897	946	1000	1046	1088	1133	1170
				Watts	83	107	130	152	169	188	206	222	240	255
3.0 [10.55]	10 x 9 Blower 3/4 HP [559 W] ECM	80,000 [23.44] & 100,000 [29.3]	Heat	CFM	1189 [561]	1199 [566]	1204 [568]	1206 [569]	1210 [571]	1202 [567]	1209 [571]	1165 [550]	1125 [531]	1061 [501]
				RPM	908	964	1024	1094	1144	1195	1234	1269	1290	1307
				Watts	247	278	311	354	385	421	448	457	454	446
3.5 [12.31]	10 x 9 Blower 3/4 HP [559 W] ECM	80,000 [23.44] & 100,000 [29.3]	Heat	CFM	1186 [560]	1191 [562]	1191 [562]	1199 [566]	1192 [563]	1182 [558]	1171 [553]	1156 [546]	1123 [530]	1045 [493]
				RPM	904	974	1023	1077	1129	1174	1216	1263	1288	1292
				Watts	235	271	296	326	354	379	400	430	425	413
3.5 [12.31]	10 x 9 Blower 3/4 HP [559 W] ECM	80,000 [23.44] & 100,000 [29.3]	Cool	CFM	1194 [564]	1200 [566]	1200 [566]	1208 [570]	1200 [566]	1190 [562]	1179 [556]	1165 [550]	1128 [532]	1045 [493]
				RPM	910	981	1027	1083	1134	1179	1219	1267	1291	1294
				Watts	239	276	300	332	359	384	405	435	428	414
4.0 [14.07]	12 x 9 Blower 1 HP [746 W] ECM	80,000 [23.44] & 100,000 [29.3]	Heat	CFM	1186 [560]	1191 [562]	1191 [562]	1199 [566]	1192 [563]	1182 [558]	1171 [553]	1156 [546]	1123 [530]	1045 [493]
				RPM	904	974	1023	1077	1129	1174	1216	1263	1288	1292
				Watts	235	271	296	326	354	379	400	430	425	413
4.0 [14.07]	12 x 9 Blower 1 HP [746 W] ECM	80,000 [23.44] & 100,000 [29.3]	Cool	CFM	1296 [612]	1294 [611]	1299 [613]	1299 [613]	1294 [611]	1288 [608]	1275 [602]	1226 [579]	1141 [538]	1050 [496]
				RPM	969	1035	1078	1133	1173	1220	1259	1295	1302	1301
				Watts	292	330	357	390	411	444	467	481	449	423
5.0 [17.59]	12 x 9 Blower 1 HP [746 W] ECM	100,000 [29.3]	Heat	CFM	1206 [569]	1215 [573]	1219 [575]	1216 [574]	1218 [575]	1220 [576]	1216 [574]	1215 [573]	1205 [569]	1195 [564]
				RPM	730	796	837	885	926	962	999	1038	1075	1112
				Watts	199	238	261	292	317	342	368	397	427	457
5.0 [17.59]	12 x 9 Blower 1 HP [746 W] ECM	100,000 [29.3]	Cool	CFM	1535 [724]	1545 [729]	1551 [732]	1554 [733]	1553 [733]	1553 [733]	1551 [732]	1548 [731]	1543 [728]	1532 [723]
				RPM	873	923	967	1005	1052	1096	1124	1149	1180	1200
				Watts	371	416	456	490	537	578	607	634	666	687
5.0 [17.59]	12 x 9 Blower 1 HP [746 W] ECM	100,000 [29.3]	Heat	CFM	1206 [569]	1215 [573]	1219 [575]	1216 [574]	1218 [575]	1220 [576]	1216 [574]	1215 [573]	1205 [569]	1195 [564]
				RPM	730	796	837	885	926	962	999	1038	1075	1112
				Watts	199	238	261	292	317	342	368	397	427	457
5.0 [17.59]	12 x 9 Blower 1 HP [746 W] ECM	100,000 [29.3]	1st Stage Cool	CFM	1248 [589]	1256 [593]	1262 [596]	1261 [595]	1262 [596]	1264 [597]	1261 [595]	1261 [595]	1253 [591]	1243 [587]
				RPM	749	808	853	903	942	979	1014	1051	1086	1121
				Watts	218	254	281	315	341	369	394	422	452	481
5.0 [17.59]	12 x 9 Blower 1 HP [746 W] ECM	100,000 [29.3]	2nd Stage Cool	CFM	1837 [867]	1850 [873]	1850 [873]	1853 [875]	1854 [875]	1847 [872]	1834 [866]	1834 [866]	1824 [861]	1818 [858]
				RPM	997	1053	1094	1128	1164	1202	1225	1256	1283	1305
				Watts	604	670	719	762	810	860	872	889	927	956

Notes: (1) Set 2 through 4 ton Cool to Tap 4 for AHRI rated performance. (2) Set 5 ton 2nd Stage Cool to Tap 4 for AHRI rated performance.

DOWN DISCHARGE PRESSURE DROP (ADD TO EXTERNAL STATIC PRESSURE)			
CFM [L/s]	800 [378]	1000 [472]	1200 [566]
Pressure Drop—Includes W.C. [kPa]	.02 [.005]	.05 [.012]	.07 [.017]
	1400 [661]	1600 [755]	1800 [849]
	.1 [.025]	.12 [.030]	.15 [.037]
	2000 [944]		.17 [.042]

[] Designates Metric Conversions



Air

INDOOR AIRFLOW PERFORMANCE RGEA14 - 230 VOLTS

Nominal Cooling Capacity Tons [kW]	Motor Speed from Factory		Heating Input BTU/HR [kW]	Manufacturer Recommended Cooling Airflow (Min/Max)	Blower Size/ Motor HP [W] & # of Speeds	Motor Speed / Tap	External Static Pressure - Inches W.C. [kPa] (Side Discharge-Dry Coil)														
	Cool	Heat					0.1 [.02]	0.2 [.05]	0.3 [.07]	0.4 [.10]	0.5 [.12]	0.6 [.15]	0.7 [.17]	0.8 [.20]	0.9 [.22]	1.0 [.25]					
2.0 [7.03]	High	High	40,000 [11.72]	700 CFM / 950 CFM	9x7 Blower 1/4 HP [186] 2 Speed (PSC Motor)	Low	CFM	822 [388]	789 [372]	750 [354]	696 [328]	624 [294]	496 [234]	402 [190]							
		RPM	917				954	994	1031	1051	1075	1105									
	High	High	60,000 [17.58]			High	CFM	992 [468]	928 [438]	873 [412]	810 [382]	741 [350]	659 [311]	490 [231]							
2.5 [8.79]	Low	Low	60,000 [17.58]	850 CFM / 1150 CFM	10x9 Blower 1/2 HP [372] 3 Speed (PSC Motor)	Med	CFM	1093 [516]	1062 [501]	1001 [472]	930 [439]	815 [385]	728 [344]	663 [313]							
		RPM	900				935	969	999	1030	1053	1084	1082								
	High	High	80,000 [23.45]			High	CFM	1239 [585]	1184 [559]	1114 [526]	1043 [492]	959 [453]	827 [390]	744 [351]							
3.0 [10.55]	High	Low	60,000 [17.58]	1000 CFM / 1400 CFM	12x9T Blower 1/2 HP [372] 2 Speed (PSC Motor)	Low	CFM	1310 [618]	1246 [588]	1186 [560]	1128 [532]	1038 [490]	955 [451]	847 [400]							
		RPM	834				867	895	918	949	971	989	1019								
	High	High	80,000 [23.45] 100,000 [29.31]			High	CFM	1644 [776]	1568 [740]	1488 [702]	1421 [671]	1330 [628]	1248 [589]	1133 [535]							
3.5 [12.31]	Tap 5	Tap 2	80,000 [23.45]	1200 CFM / 1600 CFM	12x9T Blower 3/4 HP [559] 5 Speed (Constant Torque)	Tap 1 Unused	CFM	1336 [631]	1312 [619]	1295 [611]	1241 [586]	1200 [566]	1161 [548]	1119 [528]							
		RPM	827				856	874	913	949	983	1013	1048								
	Tap 3	100,000 [29.31]			Tap 2 80K	CFM	1453 [686]	1424 [672]	1395 [658]	1347 [636]	1321 [623]	1279 [604]	1250 [590]	1214 [573]							
3.5 [12.31]	Tap 5	Tap 3	100,000 [29.31]	1200 CFM / 1600 CFM	12x9T Blower 3/4 HP [559] 5 Speed (Constant Torque)	Tap 3 Low Static Cool	CFM	1336 [631]	1312 [619]	1295 [611]	1241 [586]	1200 [566]	1161 [548]	1119 [528]							
		RPM	827				856	874	913	949	983	1013	1048								
	Tap 5	100,000 [29.31]			Tap 4 High Static Cool	CFM	1591 [751]	1563 [738]	1558 [735]	1519 [717]	1490 [703]	1458 [688]	1410 [665]	1363 [643]							
						Tap 5 High Static Cool	RPM	949	981	999	1027	1051	1086	1109							
							Watts	476	490	501	515	527	542	546							

Note: Set 3-1/2 through 5 ton Cool to Tap 4 for AHRI rated performance

[] Designates Metric Conversions



INDOOR AIRFLOW PERFORMANCE RGEA14 - 230 VOLTS (continued)

Nominal Cooling Capacity Tons [kW]	Motor Speed from Factory		Heating Input BTU/HR [kW]	Manufacturer Recommended Cooling Airflow (Min/Max)	Blower Size/ Motor HP [W] & # of Speeds	Motor Speed / Tap	External Static Pressure - Inches W.C. [kPa] (Side Discharge-Dry Coil)									
	Cool	Heat					0.1 [.02]	0.2 [.05]	0.3 [.07]	0.4 [.10]	0.5 [.12]	0.6 [.15]	0.7 [.17]	0.8 [.20]	0.9 [.22]	1.0 [.25]
4.0 [1.4,07]	Tap 2	80,000 [23.45]	1350 CFM / 1850 CFM	12x9T Blower 3/4 HP [559] 5 Speed (Constant Torque)	Tap 1 Unused	CFM	1368 [646]	1331 [628]	1299 [613]	1259 [594]	1221 [576]	1169 [552]	1137 [537]	1079 [509]	997 [471]	920 [434]
						RPM	749	782	813	849	877	911	946	979	1030	1061
						Watts	250	264	275	286	295	308	321	327	346	356
						CFM	1368 [646]	1331 [628]	1299 [613]	1259 [594]	1221 [576]	1169 [552]	1137 [537]	1079 [509]	997 [471]	920 [434]
						RPM	749	782	813	849	877	911	946	979	1030	1061
	Tap 5	100,000 [29.31]	1600 CFM / 2100 CFM	12x9R Blower 1 HP [746] 5 Speed (Constant Torque)	Tap 3 Low Cool	CFM	1447 [683]	1405 [663]	1372 [648]	1342 [633]	1307 [617]	1237 [584]	1222 [577]	1186 [560]	1121 [529]	1035 [488]
						RPM	783	809	845	872	905	938	959	998	1038	1082
						Watts	291	298	315	326	337	349	355	369	383	401
						CFM	1657 [782]	1628 [768]	1588 [749]	1559 [736]	1519 [717]	1496 [706]	1454 [686]	1426 [673]	1394 [658]	1342 [633]
						RPM	872	897	926	953	977	1005	1031	1065	1080	1113
5.0 [1.7,59]	Tap 3	100,000 [29.31]	1600 CFM / 2100 CFM	12x9R Blower 1 HP [746] 5 Speed (Constant Torque)	Tap 4 Low Static Cool	CFM	1970 [930]	1945 [918]	1920 [906]	1884 [889]	1843 [870]	1778 [859]	1704 [804]	1642 [775]	1547 [730]	1451 [685]
						RPM	1011	1038	1048	1073	1092	1104	1119	1123	1132	1145
						Watts	696	710	731	728	727	712	693	666	627	602
						CFM	1433 [676]	1407 [664]	1354 [639]	1329 [627]	1270 [599]	1235 [583]	1195 [564]	1137 [537]	1083 [511]	1030 [486]
						RPM	821	843	868	888	929	944	975	1004	1040	1065
	Tap 5	100,000 [29.31]	1600 CFM / 2100 CFM	12x9R Blower 1 HP [746] 5 Speed (Constant Torque)	Tap 5 High Cool	CFM	1233 [582]	1158 [547]	1136 [536]	1090 [514]	1039 [490]	969 [457]	902 [426]	847 [400]	791 [373]	752 [355]
						RPM	734	774	793	822	860	892	934	957	983	1011
						Watts	223	231	238	248	259	269	288	284	295	306
						CFM	1768 [834]	1730 [816]	1693 [799]	1626 [767]	1599 [755]	1558 [735]	1522 [718]	1503 [709]	1444 [681]	1399 [660]
						RPM	938	959	983	1011	1025	1052	1089	1090	1117	1134
Tap 5	100,000 [29.31]	1600 CFM / 2100 CFM	12x9R Blower 1 HP [746] 5 Speed (Constant Torque)	Tap 4 Med Cool	CFM	1926 [909]	1890 [892]	1864 [880]	1822 [860]	1794 [847]	1758 [830]	1710 [807]	1670 [788]	1579 [745]	1493 [705]	
					RPM	999	1014	1040	1061	1079	1096	1119	1128	1138	1144	
					Watts	654	660	674	688	699	708	714	705	683	661	
					CFM	2096 [989]	2057 [971]	2003 [945]	1951 [921]	1890 [892]	1819 [858]	1756 [829]	1686 [796]	1610 [760]	1498 [707]	
					RPM	1069	1092	1106	1116	1121	1129	1138	1140	1148	1154	
Tap 5	100,000 [29.31]	1600 CFM / 2100 CFM	12x9R Blower 1 HP [746] 5 Speed (Constant Torque)	Tap 5 High Cool	CFM	829	846	840	822	807	782	768	730	708	679	
					RPM	829	846	840	822	807	782	768	730	708	679	
					Watts	829	846	840	822	807	782	768	730	708	679	
					CFM	1926 [909]	1890 [892]	1864 [880]	1822 [860]	1794 [847]	1758 [830]	1710 [807]	1670 [788]	1579 [745]	1493 [705]	
					RPM	999	1014	1040	1061	1079	1096	1119	1128	1138	1144	

Note: Set 3-1/2 through 5 ton Cool to Tap 4 for AHRI rated performance

DOWN DISCHARGE PRESSURE DROP (ADD TO EXTERNAL STATIC PRESSURE)			
CFM [L/s]	800 [378]	1000 [472]	1200 [566]
Pressure Drop—Includes W.C. [kPa]	.02 [.005]	.05 [.012]	.07 [.017]
	.12 [.030]	.15 [.037]	.17 [.042]

[J] Designates Metric Conversions



INDOOR AIRFLOW PERFORMANCE RGEA14 - 460 VOLTS

Nominal Cooling Capacity Tons [kW]	Motor Speed from Factory		Heating Input BTU/HR [kW]	Manufacturer Recommended Cooling Airflow (Min/Max)	Blower Size/ Motor HP [W] & # of Speeds	Motor Speed / Tap	External Static Pressure - Inches W.C. [kPa]										
	Cool	Heat					0.1 [02]	0.2 [05]	0.3 [07]	0.4 [10]	0.5 [12]	0.6 [15]	0.7 [17]	0.8 [20]	0.9 [22]	1.0 [25]	
3.0 [10.55]	High	Low	60,000 [17.58]	1000 CFM / 1400 CFM	12x9T Blower 1/2 HP [372] 2 Speed (PSC Motor)	Low	CFM	1358 [641]	1322 [624]	1266 [597]	1209 [571]	1120 [529]	1063 [502]	970 [458]	861 [406]	828 [391]	757 [357]
		RPM	823				849	811	777	719	662	599	536	473	410	347	284
3.0 [10.55]	High	High	80,000 [23.45] 100,000 [29.31]	1000 CFM / 1400 CFM	12x9T Blower 1/2 HP [372] 2 Speed (PSC Motor)	High	CFM	1652 [780]	1596 [753]	1540 [727]	1481 [699]	1402 [662]	1320 [623]	1212 [572]	1132 [534]	1079 [509]	1004 [474]
		RPM	951				965	977	992	1007	1019	1036	1050	1063	1077		
3.5 [12.31]	Tap 5	Tap 2	80,000 [23.45]	1200 CFM / 1600 CFM	12x9T Blower 3/4 HP [559] 5 Speed (Constant Torque)	Tap 1 Unused	CFM	1362 [643]	1327 [626]	1294 [611]	1267 [598]	1207 [570]	1151 [543]	1131 [534]	1085 [512]	1022 [482]	956 [451]
							RPM	794	833	872	897	948	976	1005	1038	1078	1112
3.5 [12.31]	Tap 5	Tap 3	100,000 [29.31]	1200 CFM / 1600 CFM	12x9T Blower 3/4 HP [559] 5 Speed (Constant Torque)	Tap 2 80K	CFM	1435 [677]	1405 [663]	1378 [650]	1349 [637]	1309 [618]	1266 [597]	1233 [582]	1193 [563]	1134 [535]	1066 [503]
							RPM	844	867	892	927	961	991	1022	1052	1101	1130
4.0 [14.07]	Tap 5	Tap 2	80,000 [23.45]	1350 CFM / 1850 CFM	12x9T Blower 3/4 HP [559] 5 Speed (Constant Torque)	Tap 4 Low Static Cool	CFM	1362 [643]	1327 [626]	1294 [611]	1267 [598]	1207 [570]	1151 [543]	1131 [534]	1085 [512]	1022 [482]	956 [451]
							RPM	794	833	872	897	948	976	1005	1038	1078	1112
4.0 [14.07]	Tap 5	Tap 3	100,000 [29.31]	1350 CFM / 1850 CFM	12x9T Blower 3/4 HP [559] 5 Speed (Constant Torque)	Tap 5 High Static Cool	CFM	1643 [775]	1609 [759]	1580 [746]	1560 [736]	1511 [713]	1494 [705]	1443 [681]	1404 [663]	1335 [630]	1244 [587]
							RPM	927	954	986	1001	1035	1052	1083	1111	1122	1133
4.0 [14.07]	Tap 5	Tap 1 Unused	80,000 [23.45]	1350 CFM / 1850 CFM	12x9T Blower 3/4 HP [559] 5 Speed (Constant Torque)	Tap 1 Unused	CFM	1340 [632]	1305 [616]	1263 [596]	1227 [579]	1186 [560]	1162 [548]	1104 [521]	1020 [481]	960 [453]	897 [423]
							RPM	776	796	831	869	898	925	966	1011	1044	1076
4.0 [14.07]	Tap 5	Tap 2	80,000 [23.45]	1350 CFM / 1850 CFM	12x9T Blower 3/4 HP [559] 5 Speed (Constant Torque)	Tap 2 80K	CFM	1340 [632]	1305 [616]	1263 [596]	1227 [579]	1186 [560]	1162 [548]	1104 [521]	1020 [481]	960 [453]	897 [423]
							RPM	776	796	831	869	898	925	966	1011	1044	1076
4.0 [14.07]	Tap 5	Tap 3	100,000 [29.31]	1350 CFM / 1850 CFM	12x9T Blower 3/4 HP [559] 5 Speed (Constant Torque)	Tap 3 100K	CFM	1467 [692]	1448 [683]	1404 [663]	1373 [648]	1339 [632]	1306 [616]	1250 [590]	1210 [571]	1164 [549]	1087 [513]
							RPM	826	855	884	910	939	969	1003	1030	1067	1108
4.0 [14.07]	Tap 5	Tap 4 Low Static Cool	100,000 [29.31]	1350 CFM / 1850 CFM	12x9T Blower 3/4 HP [559] 5 Speed (Constant Torque)	Tap 4 Low Static Cool	CFM	1634 [771]	1595 [753]	1547 [730]	1530 [722]	1487 [702]	1462 [690]	1438 [679]	1378 [650]	1352 [638]	1298 [613]
							RPM	894	923	950	981	1000	1030	1051	1079	1106	1126
4.0 [14.07]	Tap 5	Tap 5 High Static Cool	100,000 [29.31]	1350 CFM / 1850 CFM	12x9T Blower 3/4 HP [559] 5 Speed (Constant Torque)	Tap 5 High Static Cool	CFM	1941 [916]	1915 [904]	1878 [886]	1814 [856]	1773 [837]	1709 [807]	1655 [781]	1570 [741]	1488 [702]	1374 [648]
							RPM	1028	1047	1068	1091	1104	1113	1124	1136	1142	1147
4.0 [14.07]	Tap 5	Tap 5 High Static Cool	100,000 [29.31]	1350 CFM / 1850 CFM	12x9T Blower 3/4 HP [559] 5 Speed (Constant Torque)	Tap 5 High Static Cool	Watts	708	725	729	727	717	696	673	647	618	571
							Watts	708	725	729	727	717	696	673	647	618	571

Note: Set 3-1/2 through 5 ton Cool to Tap 4 for AHRI rated performance

[] Designates Metric Conversions





Air

Indoor Airflow Performance

RGEA15 Series

INDOOR AIRFLOW PERFORMANCE RGEA14 - 460 VOLTS (continued)

Nominal Cooling Capacity Tons [kW]	Motor Speed from Factory		Heating Input BTU/HR [kW]	Manufacturer Recommended Cooling Airflow (Min/Max)	Blower Size/ Motor HP [W] & # of Speeds	Motor Speed / Tap	External Static Pressure - Inches W.C. [kPa]											
	Cool	Heat					0.1 [0.2]	0.2 [0.05]	0.3 [0.07]	0.4 [0.10]	0.5 [0.12]	0.6 [0.15]	0.7 [0.17]	0.8 [0.20]	0.9 [0.22]	1.0 [0.25]		
5.0 [17.59]					12x9R Blower 1 HP [746] 5 Speed (Constant Torque)	Tap 1 100K Heat	CFM	1484 [700]	1440 [680]	1405 [663]	1360 [642]	1319 [622]	1280 [604]	1238 [584]	1186 [560]	1128 [532]	1047 [494]	
				RPM			812	841	863	889	918	938	965	994	1026	1066		
				Watts			330	338	355	354	379	381	395	408	423	419		
							Tap 2 Unused	CFM	1289 [608]	1239 [585]	1189 [561]	1140 [538]	1101 [520]	1052 [496]	969 [457]	918 [433]	860 [406]	812 [383]
				RPM		726		755	786	815	846	876	912	935	964	986		
				Watts		233		248	249	259	275	292	309	308	321	330		
							Tap 3 Low Cool	CFM	1787 [843]	1746 [824]	1705 [805]	1680 [793]	1621 [765]	1607 [758]	1564 [738]	1530 [722]	1505 [710]	1424 [672]
		Tap 5	Tap 1	100,000 [29.31]		1600 CFM/ 2100 CFM		RPM	950	970	1000	1012	1042	1055	1079	1108	1113	1130
								Watts	525	538	545	579	571	596	615	610	631	626
							Tap 4 Med Cool	CFM	1954 [922]	1927 [909]	1889 [892]	1843 [870]	1808 [853]	1738 [820]	1671 [789]	1620 [765]	1543 [728]	1433 [676]
						RPM		1030	1042	1061	1082	1100	1121	1130	1138	1146		
						Watts		664	673	683	696	704	700	697	684	667	635	
							Tap 5 High Cool	CFM	2095 [989]	2045 [965]	1983 [936]	1905 [899]	1840 [868]	1792 [846]	1712 [808]	1641 [774]	1558 [735]	1397 [659]
						RPM		1103	1114	1114	1123	1125	1130	1139	1140	1144	1148	
						Watts		829	841	832	803	785	770	749	710	685	633	

Note: Set 3-1/2 through 5 ton Cool to Tap 4 for AHRI rated performance

DOWN DISCHARGE PRESSURE DROP (ADD TO EXTERNAL STATIC PRESSURE)

CFM [L/s]	800 [378]	1000 [472]	1200 [566]	1400 [661]	1600 [755]	1800 [849]	2000 [944]
Pressure Drop—Includes W.C. [kPa]	.02 [.005]	.05 [.012]	.07 [.017]	.1 [.025]	.12 [.030]	.15 [.037]	.17 [.042]

[] Designates Metric Conversions



INDOOR AIRFLOW PERFORMANCE RGEA15 - 208/230 VOLTS



Air

Indoor Airflow Performance
RGEA15 Series

Nominal Cooling Capacity Tons [kW]	Blower Size/ Motor HP [W] & Motor Type	Nominal Heating Capacity BTU/HR [kW]	Motor Speed	External Static Pressure - Inches W.C. [kPa] (Side Discharge-Dry Coil)																			
				0.1 [0.02]	0.2 [0.05]	0.3 [0.07]	0.4 [0.10]	0.5 [0.12]	0.6 [0.15]	0.7 [0.17]	0.8 [0.20]	0.9 [0.22]	1.0 [0.25]										
				CFM	RPM	Watts	CFM	RPM	Watts	CFM	RPM	Watts	CFM	RPM	Watts	CFM	RPM	Watts	CFM	RPM	Watts		
2.0 [7.03]	10 x 9 Blower 1/2 HP [372 W] ECM	60,000 [17.58]	Heat	766 [362]	773 [365]	771 [364]	770 [363]	768 [362]	757 [357]	751 [354]	742 [350]	726 [343]	715 [337]	649	746	829	897	946	1000	1046	1088	1133	1170
				83	107	130	152	169	188	206	222	240	255	891 [421]	902 [426]	910 [429]	906 [428]	912 [430]	906 [428]	903 [426]	891 [421]	876 [413]	868 [410]
				747	831	895	957	1017	1068	1111	1151	1186	1223	RPM	Watts	CFM	RPM	Watts	CFM	RPM	Watts	CFM	RPM
	80,000 [23.44]	Heat	1189 [561]	1198 [565]	1203 [568]	1210 [571]	1212 [572]	1208 [570]	1193 [563]	1146 [564]	1146 [564]	1146 [564]	1072 [506]	894	964	1008	1084	1142	1187	1234	1285	1301	1310
			236	273	299	344	378	411	441	477	475	446	891 [421]	902 [426]	910 [429]	906 [428]	912 [430]	906 [428]	903 [426]	891 [421]	876 [413]	868 [410]	
			747	831	895	957	1017	1068	1111	1151	1186	1223	RPM	Watts	CFM	RPM	Watts	CFM	RPM	Watts	CFM	RPM	Watts
2.5 [8.79]	10 x 9 Blower 1/2 HP [372 W] ECM	60,000 [17.58]	Heat	766 [362]	773 [365]	771 [364]	770 [363]	768 [362]	757 [357]	751 [354]	742 [350]	726 [343]	715 [337]	649	746	829	897	946	1000	1046	1088	1133	1170
				83	107	130	152	169	188	206	222	240	255	891 [421]	902 [426]	910 [429]	906 [428]	912 [430]	906 [428]	903 [426]	891 [421]	876 [413]	868 [410]
				747	831	895	957	1017	1068	1111	1151	1186	1223	RPM	Watts	CFM	RPM	Watts	CFM	RPM	Watts	CFM	RPM
	80,000 [23.44]	Cool	1189 [561]	1198 [565]	1203 [568]	1210 [571]	1212 [572]	1208 [570]	1193 [563]	1146 [564]	1146 [564]	1146 [564]	1072 [506]	894	964	1008	1084	1142	1187	1234	1285	1301	1310
			236	273	299	344	378	411	441	477	475	446	891 [421]	902 [426]	910 [429]	906 [428]	912 [430]	906 [428]	903 [426]	891 [421]	876 [413]	868 [410]	
			747	831	895	957	1017	1068	1111	1151	1186	1223	RPM	Watts	CFM	RPM	Watts	CFM	RPM	Watts	CFM	RPM	Watts

Notes: (1) Set 2 through 4 ton Cool to Tap 4 for AHRI rated performance. (2) Set 5 ton 2nd Stage Cool to Tap 4 for AHRI rated performance.

[J] Designates Metric Conversions



INTEGRATED AIR & WATER

INDOOR AIRFLOW PERFORMANCE RGEA15 - 208/230 VOLTS (continued)

Nominal Cooling Capacity Tons [kW]	Blower Size/ Motor HP [W] & Motor Type	Nominal Heating Capacity Btu/hr [kW]	Motor Speed	External Static Pressure - Inches W.C. [kPa] (Side Discharge-Dry Coil)											
				0.1 [0.02]	0.2 [0.05]	0.3 [0.07]	0.4 [0.10]	0.5 [0.12]	0.6 [0.15]	0.7 [0.17]	0.8 [0.20]	0.9 [0.22]	1.0 [0.25]		
3.0 [10.55]	10 x 9 Blower 1/2 HP [372 W] ECM	60,000 [17.58]	Heat	CFM	766 [362]	773 [365]	771 [364]	770 [363]	768 [362]	757 [357]	751 [354]	742 [350]	726 [343]	715 [337]	
				RPM	649	746	829	897	946	1000	1046	1088	1133	1170	
				Watts	83	107	130	152	169	188	206	222	240	255	265
		Cool	CFM	1189 [561]	1199 [566]	1204 [568]	1206 [569]	1210 [571]	1202 [567]	1209 [571]	1234	1269	1290	1307	
			RPM	908	964	1024	1094	1144	1195	1234	1269	1290	1307		
			Watts	247	278	311	354	385	421	448	457	454	446		
3.5 [12.31]	10 x 9 Blower 3/4 HP [559 W] ECM	80,000 [23.44] & 100,000 [29.3]	Heat	CFM	1186 [560]	1191 [562]	1199 [566]	1208 [570]	1192 [563]	1182 [558]	1171 [553]	1156 [546]	1123 [530]	1045 [493]	
				RPM	904	974	1023	1077	1129	1174	1216	1263	1288	1292	
				Watts	235	271	296	326	354	379	400	430	425	413	
		Cool	CFM	1194 [564]	1200 [566]	1200 [566]	1208 [570]	1200 [566]	1190 [562]	1179 [556]	1219	1267	1291	1294	
			RPM	910	981	1027	1083	1134	1179	1219	1259	1295	1302		
			Watts	239	276	300	332	359	384	405	435	428	414		
4.0 [14.07]	10 x 9 Blower 3/4 HP [559 W] ECM	80,000 [23.44] & 100,000 [29.3]	Heat	CFM	1186 [560]	1191 [562]	1199 [566]	1216 [574]	1192 [563]	1182 [558]	1171 [553]	1156 [546]	1123 [530]	1045 [493]	
				RPM	904	974	1023	1077	1129	1174	1216	1263	1288	1292	
				Watts	235	271	296	326	354	379	400	430	425	413	
		Cool	CFM	1296 [612]	1294 [611]	1299 [613]	1299 [613]	1294 [611]	1288 [608]	1275 [602]	1226 [579]	1141 [538]	1050 [496]	1301	
			RPM	969	1035	1078	1133	1173	1220	1259	1295	1302	1301		
			Watts	292	330	357	390	411	444	467	481	449	423		
5.0 [17.59]	12 x 9 Blower 1 HP [746 W] ECM	80,000 [23.44] & 100,000 [29.3]	Heat	CFM	1206 [569]	1215 [573]	1219 [575]	1216 [574]	1218 [575]	1220 [576]	1216 [574]	1215 [573]	1205 [569]	1195 [564]	
				RPM	730	796	837	885	926	962	999	1038	1075	1112	
				Watts	199	238	261	292	317	342	368	397	427	457	
		Cool	CFM	1535 [724]	1545 [729]	1551 [732]	1554 [733]	1553 [733]	1553 [733]	1551 [732]	1548 [731]	1543 [728]	1532 [723]	1200	
			RPM	873	923	967	1005	1052	1096	1124	1149	1180	1200		
			Watts	371	416	456	490	537	578	607	634	666	687		
5.0 [17.59]	12 x 9 Blower 1 HP [746 W] ECM	100,000 [29.3]	Heat	CFM	1206 [569]	1215 [573]	1219 [575]	1216 [574]	1218 [575]	1220 [576]	1216 [574]	1215 [573]	1205 [569]	1195 [564]	
				RPM	730	796	837	885	926	962	999	1038	1075	1112	
				Watts	199	238	261	292	317	342	368	397	427	457	
		1st Stage Cool	CFM	1248 [589]	1256 [593]	1262 [596]	1261 [595]	1262 [596]	1264 [597]	1261 [595]	1261 [595]	1253 [591]	1243 [587]	1121	
			RPM	749	808	853	903	942	979	1014	1051	1086	1121		
			Watts	218	254	281	315	341	369	394	422	452	481		
	2nd Stage Cool	CFM	1837 [867]	1850 [873]	1850 [873]	1853 [875]	1854 [875]	1847 [872]	1834 [866]	1834 [866]	1824 [861]	1818 [858]	1305		
		RPM	997	1053	1094	1128	1164	1202	1225	1256	1283	1305			
		Watts	604	670	719	762	810	860	872	889	927	956			

Notes: (1) Set 2 through 4 ton Cool to Tap 4 for AHRI rated performance. (2) Set 5 ton 2nd Stage Cool to Tap 4 for AHRI rated performance.

[] Designates Metric Conversions

INDOOR AIRFLOW PERFORMANCE RGEA15 - 460 VOLTS



Air

Indoor Airflow Performance
RGEA15 Series

Nominal Cooling Capacity Tons [kW]	Motor Speed from Factory		Heating Input BTU/HR [kW]	Manufacturer Recommended Cooling Airflow (Min/Max)	Blower Size/ Motor HP [W] & # of Speeds	Motor Speed / Tap	External Static Pressure - Inches W.C. [kPa]												
	Cool	Heat					0.1 [0.02]	0.2 [0.05]	0.3 [0.07]	0.4 [0.10]	0.5 [0.12]	0.6 [0.15]	0.7 [0.17]	0.8 [0.20]	0.9 [0.22]	1.0 [0.25]			
3.0 [10.55]	Tap 1	CFM	60,000 [17.58]	1000 CFM / 1400 CFM	12x9T Blower 1/2 HP [372] 5 Speed (Constant Torque)	Tap 1 60K	912 [430]	871 [411]	808 [381]	734 [346]	655 [309]	571 [269]	520 [245]	447 [211]					
		RPM	634			664	722	769	811	850	881	906							
		Watts	111			116	131	137	149	151	162	165							
	Tap 2	CFM	80,000 [23.45]			1362 [643]	1327 [626]	1294 [611]	1267 [598]	1207 [570]	1151 [543]	1131 [534]	1085 [512]	1022 [482]	956 [451]				
		RPM	794			833	872	897	948	976	1005	1038	1078	1112					
		Watts	287			295	317	317	331	351	361	365	370	399					
	Tap 3	CFM	100,000 [29.31]			1435 [677]	1405 [663]	1378 [650]	1349 [637]	1309 [618]	1266 [597]	1233 [582]	1193 [563]	1134 [535]	1066 [503]				
		RPM	844			867	892	927	961	991	1022	1052	1101	1130					
		Watts	337			340	358	368	390	389	409	411	438	446					
		CFM	1163 [549]			1144 [540]	1086 [513]	1073 [506]	987 [466]	927 [437]	870 [411]	819 [387]							
3.5 [12.31]	Tap 1	CFM	80,000 [23.45]	1200 CFM / 1600 CFM	12x9T Blower 3/4 HP [559] 5 Speed (Constant Torque)	Tap 1 Unused	1362 [643]	1327 [626]	1294 [611]	1267 [598]	1207 [570]	1151 [543]	1131 [534]	1085 [512]	1022 [482]	956 [451]			
		RPM	794			833	872	897	948	976	1005	1038	1078	1112					
		Watts	287			295	317	317	331	351	361	365	370	399					
	Tap 2	CFM	100,000 [29.31]			1362 [643]	1327 [626]	1294 [611]	1267 [598]	1207 [570]	1151 [543]	1131 [534]	1085 [512]	1022 [482]	956 [451]				
		RPM	794			833	872	897	948	976	1005	1038	1078	1112					
		Watts	287			295	317	317	331	351	361	365	370	399					
	Tap 3	CFM	100,000 [29.31]			1435 [677]	1405 [663]	1378 [650]	1349 [637]	1309 [618]	1266 [597]	1233 [582]	1193 [563]	1134 [535]	1066 [503]				
		RPM	844			867	892	927	961	991	1022	1052	1101	1130					
		Watts	337			340	358	368	390	389	409	411	438	446					
		CFM	1362 [643]			1327 [626]	1294 [611]	1267 [598]	1207 [570]	1151 [543]	1131 [534]	1085 [512]	1022 [482]	956 [451]					
Tap 5	CFM	1643 [775]	1609 [759]	1580 [746]	1560 [736]	1511 [713]	1494 [705]	1443 [681]	1404 [663]	1335 [630]	1244 [587]								
	RPM	927	954	986	1001	1035	1052	1083	1111	1122	1133								
	Watts	461	475	490	506	518	528	535	548	530	502								
	CFM	1163 [549]	1144 [540]	1086 [513]	1073 [506]	987 [466]	927 [437]	870 [411]	819 [387]										
	CFM	1435 [677]	1405 [663]	1378 [650]	1349 [637]	1309 [618]	1266 [597]	1233 [582]	1193 [563]	1134 [535]	1066 [503]								

Notes: (1) Set 2 through 4 ton Cool to Tap 4 for AHRI rated performance. (2) Set 5 ton 2nd Stage Cool to Tap 4 for AHRI rated performance.

[] Designates Metric Conversions



INDOOR AIRFLOW PERFORMANCE RGEA15 - 460 VOLTS (continued)

Nominal Cooling Capacity Tons [kW]	Motor Speed from Factory		Heating Input BTU/HR [kW]	Manufacturer Recommended Cooling Airflow (Min/Max)	Blower Size/ Motor HP [W] & # of Speeds	Motor Speed / Tap	External Static Pressure - Inches W.C. [kPa] (Side Discharge-Dry Coil)									
	Cool	Heat					0.1 [0.2]	0.2 [0.05]	0.3 [0.07]	0.4 [0.10]	0.5 [0.12]	0.6 [0.15]	0.7 [0.17]	0.8 [0.20]	0.9 [0.22]	1.0 [0.25]
4.0 [14.07]	Tap 2	80,000 [23.45]	1350 CFM / 1850 CFM	12x9T Blower 3/4 HP [559] 5 Speed (Constant Torque)	Tap 1 Unused	CFM	1340 [632]	1305 [616]	1263 [596]	1227 [579]	1186 [560]	1162 [548]	1104 [521]	1020 [481]	960 [453]	897 [423]
						RPM	776	796	831	869	898	925	966	1011	1044	1076
						Watts	261	268	279	291	303	310	323	339	351	361
	Tap 5	100,000 [29.31]			Tap 3	CFM	1340 [632]	1305 [616]	1263 [596]	1227 [579]	1186 [560]	1162 [548]	1104 [521]	1020 [481]	960 [453]	897 [423]
						RPM	776	796	831	869	898	925	966	1011	1044	1076
						Watts	261	268	279	291	303	310	323	339	351	361
	Tap 3	100,000 [29.31]			Tap 4	CFM	1467 [692]	1448 [683]	1404 [663]	1373 [648]	1339 [632]	1306 [616]	1250 [590]	1210 [571]	1164 [549]	1087 [513]
						RPM	826	855	884	910	939	969	1003	1030	1067	1108
						Watts	328	344	348	363	379	387	398	408	418	434
	Tap 4	100,000 [29.31]			Tap 5	CFM	1634 [771]	1595 [753]	1547 [730]	1530 [722]	1487 [702]	1462 [690]	1438 [679]	1378 [650]	1352 [638]	1298 [613]
RPM			894	923		950	981	1000	1030	1051	1079	1106	1126			
Watts			432	446		451	468	479	490	508	510	520	520			
5.0 [17.59]	1st Stage Tap 2	100,000 [29.31]	1600 CFM / 2100 CFM	12x9R Blower 1 HP [746] 5 Speed (Constant Torque)	Tap 1 100K Heat	CFM	1484 [700]	1440 [680]	1405 [663]	1360 [642]	1319 [622]	1280 [604]	1238 [584]	1186 [560]	1128 [532]	1047 [494]
						RPM	812	841	863	889	918	938	965	994	1026	1066
						Watts	330	338	355	354	379	381	395	408	423	419
	2nd Stage Tap 5	100,000 [29.31]			Tap 2 1st Stage Cool	CFM	1289 [608]	1239 [585]	1189 [561]	1140 [538]	1101 [520]	1052 [496]	969 [457]	918 [433]	860 [406]	812 [383]
						RPM	726	755	786	815	846	876	912	935	964	986
						Watts	233	248	249	259	275	292	309	308	321	330
	2nd Stage Tap 5	100,000 [29.31]			Tap 3 Unused	CFM	1787 [843]	1746 [824]	1705 [805]	1680 [793]	1621 [765]	1607 [758]	1564 [738]	1530 [722]	1505 [710]	1424 [672]
						RPM	950	970	1000	1012	1042	1055	1079	1108	1113	1130
						Watts	525	538	545	579	571	596	615	610	631	626
	2nd Stage Tap 5	100,000 [29.31]			Tap 4 2nd stage Low Static Cool	CFM	1954 [922]	1927 [909]	1889 [892]	1843 [870]	1808 [853]	1738 [820]	1671 [789]	1620 [765]	1543 [728]	1433 [676]
RPM			1030	1042		1061	1082	1100	1121	1130	1133	1138	1146			
Watts			664	673		683	696	704	700	697	684	667	635			
2nd Stage Tap 5	100,000 [29.31]	Tap 5 2nd Stage High Static Cool	CFM	2095 [989]	2045 [965]	1983 [936]	1905 [899]	1840 [868]	1792 [846]	1712 [808]	1641 [774]	1558 [735]	1397 [659]			
			RPM	1103	1114	1114	1123	1125	1130	1139	1140	1144	1148			
			Watts	829	841	832	803	785	770	749	710	685	633			

Notes: (1) Set 2 through 4 ton Cool to Tap 4 for AHRI rated performance. (2) Set 5 ton 2nd Stage Cool to Tap 4 for AHRI rated performance.

DOWN DISCHARGE PRESSURE DROP (ADD TO EXTERNAL STATIC PRESSURE)							
CFM [L/s]	800 [378]	1000 [472]	1200 [566]	1400 [661]	1600 [755]	1800 [849]	2000 [944]
Pressure Drop—Includes W.C. [kPa]	.02 [.005]	.05 [.012]	.07 [.017]	.1 [.025]	.12 [.030]	.15 [.037]	.17 [.042]

[] Designates Metric Conversions

ELECTRICAL DATA – RGEA14 SERIES									
		024AJD041AA	024AJD04XAA	024AJD061AA	024AJD06XAA	024AJT061AB	024AJT06XAB	024AJT081AB	024AJT08XAB
Unit Information	Unit Operating Voltage Range	187-253	187-253	187-253	187-253	187-253	187-253	187-253	187-253
	Volts	208/230	208/230	208/230	208/230	208/230	208/230	208/230	208/230
	Phase	1	1	1	1	1	1	1	1
	Hz	60	60	60	60	60	60	60	60
	Minimum Circuit Ampacity	17	17	17	17	19	19	19	19
	Minimum Overcurrent Protection Device Size	20	20	20	20	20	20	20	20
	Maximum Overcurrent Protection Device Size	25	25	25	25	25	25	25	25
Compressor Motor	No.	1	1	1	1	1	1	1	1
	Volts	208/230	208/230	208/230	208/230	208/230	208/230	208/230	208/230
	Phase	1	1	1	1	1	1	1	1
	RPM	3450	3450	3450	3450	3450	3450	3450	3450
	HP, Compressor 1	2 1/6	2 1/6	2 1/6	2 1/6	2 1/6	2 1/6	2 1/6	2 1/6
	Amps (RLA), Comp. 1	11.2	11.2	11.2	11.2	11.2	11.2	11.2	11.2
	Amps (LRA), Comp. 1	60.8	60.8	60.8	60.8	60.8	60.8	60.8	60.8
	HP, Compressor 2								
	Amps (RLA), Comp. 2								
Amps (LRA), Comp. 2									
Condenser Motor	No.	1	1	1	1	1	1	1	1
	Volts	208/230	208/230	208/230	208/230	208/230	208/230	208/230	208/230
	Phase	1	1	1	1	1	1	1	1
	HP	1/3	1/3	1/3	1/3	1/3	1/3	1/3	1/3
	Amps (FLA, each)	1.5	1.5	1.5	1.5	1.5	1.5	1.5	1.5
	Amps (LRA, each)	3	3	3	3	3	3	3	3
Evaporator Fan	No.	1	1	1	1	1	1	1	1
	Volts	208/230	208/230	208/230	208/230	208/230	208/230	208/230	208/230
	Phase	1	1	1	1	1	1	1	1
	HP	1/4	1/4	1/4	1/4	1/3	1/3	1/3	1/3
	Amps (FLA, each)	1.3	1.3	1.3	1.3	2.8	2.8	2.8	2.8
	Amps (LRA, each)	2.3	2.3	2.3	2.3				

1. Horsepower Per Compressor.

2. Amp Draw Per Motor. Multiply Value By Number of Motors to Determine Total Amps.

ELECTRICAL DATA – RGEA14 SERIES

		030AJD061AA	030AJD06XAA	030AJD081AA	030AJD08XAA	030AJT061AB	030AJT06XAB	030AJT081AB	030AJT08XAB
Unit Information	Unit Operating Voltage Range	187-253	187-253	187-253	187-253	187-253	187-253	187-253	187-253
	Volts	208/230	208/230	208/230	208/230	208/230	208/230	208/230	208/230
	Phase	1	1	1	1	1	1	1	1
	Hz	60	60	60	60	60	60	60	60
	Minimum Circuit Ampacity	20	20	20	20	21	21	21	21
	Minimum Overcurrent Protection Device Size	20	20	20	20	25	25	25	25
	Maximum Overcurrent Protection Device Size	30	30	30	30	30	30	30	30
Compressor Motor	No.	1	1	1	1	1	1	1	1
	Volts	208/230	208/230	208/230	208/230	208/230	208/230	208/230	208/230
	Phase	1	1	1	1	1	1	1	1
	RPM	3450	3450	3450	3450	3450	3450	3450	3450
	HP, Compressor 1	2 2/3	2 2/3	2 2/3	2 2/3	2 2/3	2 2/3	2 2/3	2 2/3
	Amps (RLA), Comp. 1	12.8	12.8	12.8	12.8	12.8	12.8	12.8	12.8
	Amps (LRA), Comp. 1	64	64	64	64	64	64	64	64
	HP, Compressor 2								
	Amps (RLA), Comp. 2								
Amps (LRA), Comp. 2									
Condenser Motor	No.	1	1	1	1	1	1	1	1
	Volts	208/230	208/230	208/230	208/230	208/230	208/230	208/230	208/230
	Phase	1	1	1	1	1	1	1	1
	HP	1/3	1/3	1/3	1/3	1/3	1/3	1/3	1/3
	Amps (FLA, each)	1.5	1.5	1.5	1.5	1.5	1.5	1.5	1.5
	Amps (LRA, each)	3	3	3	3	3	3	3	3
Evaporator Fan	No.	1	1	1	1	1	1	1	1
	Volts	208/230	208/230	208/230	208/230	208/230	208/230	208/230	208/230
	Phase	1	1	1	1	1	1	1	1
	HP	1/2	1/2	1/2	1/2	1/2	1/2	1/2	1/2
	Amps (FLA, each)	2.4	2.4	2.4	2.4	2.8	2.8	2.8	2.8
	Amps (LRA, each)	5.1	5.1	5.1	5.1				

1. Horsepower Per Compressor.
2. Amp Draw Per Motor. Multiply Value By Number of Motors to Determine Total Amps.



ELECTRICAL DATA – RGEA14 SERIES										
		036ACD061AA	036ACD06XAA	036ACD081AA	036ACD08XAA	036ACD101AA	036ACD10XAA	036ADD061AA	036ADD06XAA	036ADD081AA
Unit Information	Unit Operating Voltage Range	187-253	187-253	187-253	187-253	187-253	187-253	414-506	414-506	414-506
	Volts	208/230	208/230	208/230	208/230	208/230	208/230	460	460	460
	Phase	3	3	3	3	3	3	3	3	3
	Hz	60	60	60	60	60	60	60	60	60
	Minimum Circuit Ampacity	16	16	16	16	16	16	9	9	9
	Minimum Overcurrent Protection Device Size	20	20	20	20	20	20	15	15	15
	Maximum Overcurrent Protection Device Size	20	20	20	20	20	20	15	15	15
Compressor Motor	No.	1	1	1	1	1	1	1	1	1
	Volts	208/230	208/230	208/230	208/230	208/230	208/230	460	460	460
	Phase	3	3	3	3	3	3	3	3	3
	RPM	3450	3450	3450	3450	3450	3450	3450	3450	3450
	HP, Compressor 1	3 1/3	3 1/3	3 1/3	3 1/3	3 1/3	3 1/3	3 1/3	3 1/3	3 1/3
	Amps (RLA), Comp. 1	9	9	9	9	9	9	5.6	5.6	5.6
	Amps (LRA), Comp. 1	71	71	71	71	71	71	38	38	38
	HP, Compressor 2									
	Amps (RLA), Comp. 2									
Amps (LRA), Comp. 2										
Condenser Motor	No.	1	1	1	1	1	1	1	1	1
	Volts	208/230	208/230	208/230	208/230	208/230	208/230	460	460	460
	Phase	1	1	1	1	1	1	1	1	1
	HP	1/3	1/3	1/3	1/3	1/3	1/3	1/3	1/3	1/3
	Amps (FLA, each)	1.5	1.5	1.5	1.5	1.5	1.5	0.8	0.8	0.8
	Amps (LRA, each)	3	3	3	3	3	3	1.6	1.6	1.6
Evaporator Fan	No.	1	1	1	1	1	1	1	1	1
	Volts	208/230	208/230	208/230	208/230	208/230	208/230	460	460	460
	Phase	1	1	1	1	1	1	1	1	1
	HP	1/2	1/2	1/2	1/2	1/2	1/2	1/2	1/2	1/2
	Amps (FLA, each)	2.5	2.5	2.5	2.5	2.5	2.5	1.2	1.2	1.2
	Amps (LRA, each)	4.6	4.6	4.6	4.6	4.6	4.6	2.4	2.4	2.4

1. Horsepower Per Compressor.

2. Amp Draw Per Motor. Multiply Value By Number of Motors to Determine Total Amps.

ELECTRICAL DATA – RGEA14 SERIES

		036ADD08XAA	036ADD101AA	036ADD10XAA	036AJD061AA	036AJD06XAA	036AJD081AA	036AJD08XAA	036AJD101AA	036AJD10XAA
Unit Information	Unit Operating Voltage Range	414-506	414-506	414-506	187-253	187-253	187-253	187-253	187-253	187-253
	Volts	460	460	460	208/230	208/230	208/230	208/230	208/230	208/230
	Phase	3	3	3	1	1	1	1	1	1
	Hz	60	60	60	60	60	60	60	60	60
	Minimum Circuit Ampacity	9	9	9	22	22	22	22	22	22
	Minimum Overcurrent Protection Device Size	15	15	15	25	25	25	25	25	25
	Maximum Overcurrent Protection Device Size	15	15	15	35	35	35	35	35	35
Compressor Motor	No.	1	1	1	1	1	1	1	1	1
	Volts	460	460	460	208/230	208/230	208/230	208/230	208/230	208/230
	Phase	3	3	3	1	1	1	1	1	1
	RPM	3450	3450	3450	3450	3450	3450	3450	3450	3450
	HP, Compressor 1	3 1/3	3 1/3	3 1/3	3 1/3	3 1/3	3 1/3	3 1/3	3 1/3	3 1/3
	Amps (RLA), Comp. 1	5.6	5.6	5.6	14.1	14.1	14.1	14.1	14.1	14.1
	Amps (LRA), Comp. 1	38	38	38	77	77	77	77	77	77
	HP, Compressor 2									
	Amps (RLA), Comp. 2									
Amps (LRA), Comp. 2										
Condenser Motor	No.	1	1	1	1	1	1	1	1	1
	Volts	460	460	460	208/230	208/230	208/230	208/230	208/230	208/230
	Phase	1	1	1	1	1	1	1	1	1
	HP	1/3	1/3	1/3	1/3	1/3	1/3	1/3	1/3	1/3
	Amps (FLA, each)	0.8	0.8	0.8	1.5	1.5	1.5	1.5	1.5	1.5
	Amps (LRA, each)	1.6	1.6	1.6	3	3	3	3	3	3
Evaporator Fan	No.	1	1	1	1	1	1	1	1	1
	Volts	460	460	460	208/230	208/230	208/230	208/230	208/230	208/230
	Phase	1	1	1	1	1	1	1	1	1
	HP	1/2	1/2	1/2	1/2	1/2	1/2	1/2	1/2	1/2
	Amps (FLA, each)	1.2	1.2	1.2	2.5	2.5	2.5	2.5	2.5	2.5
Amps (LRA, each)	2.4	2.4	2.4	4.6	4.6	4.6	4.6	4.6	4.6	

1. Horsepower Per Compressor.
2. Amp Draw Per Motor. Multiply Value By Number of Motors to Determine Total Amps.



ELECTRICAL DATA – RGEA14 SERIES							
		036AJT061AB	036AJT06XAB	036AJT081AB	036AJT08XAB	036AJT101AB	036AJT10XAB
Unit Information	Unit Operating Voltage Range	187-253	187-253	187-253	187-253	187-253	187-253
	Volts	208/230	208/230	208/230	208/230	208/230	208/230
	Phase	1	1	1	1	1	1
	Hz	60	60	60	60	60	60
	Minimum Circuit Ampacity	24	24	24	24	24	24
	Minimum Overcurrent Protection Device Size	25	25	25	25	25	25
	Maximum Overcurrent Protection Device Size	35	35	35	35	35	35
Compressor Motor	No.	1	1	1	1	1	1
	Volts	208/230	208/230	208/230	208/230	208/230	208/230
	Phase	1	1	1	1	1	1
	RPM	3450	3450	3450	3450	3450	3450
	HP, Compressor 1	3 1/3	3 1/3	3 1/3	3 1/3	3 1/3	3 1/3
	Amps (RLA), Comp. 1	14.1	14.1	14.1	14.1	14.1	14.1
	Amps (LRA), Comp. 1	77	77	77	77	77	77
	HP, Compressor 2						
	Amps (RLA), Comp. 2						
	Amps (LRA), Comp. 2						
Condenser Motor	No.	1	1	1	1	1	1
	Volts	208/230	208/230	208/230	208/230	208/230	208/230
	Phase	1	1	1	1	1	1
	HP	1/3	1/3	1/3	1/3	1/3	1/3
	Amps (FLA, each)	1.5	1.5	1.5	1.5	1.5	1.5
	Amps (LRA, each)	3	3	3	3	3	3
Evaporator Fan	No.	1	1	1	1	1	1
	Volts	208/230	208/230	208/230	208/230	208/230	208/230
	Phase	1	1	1	1	1	1
	HP	1/2	1/2	1/2	1/2	1/2	1/2
	Amps (FLA, each)	4.1	4.1	4.1	4.1	4.1	4.1
	Amps (LRA, each)						

1. Horsepower Per Compressor.

2. Amp Draw Per Motor. Multiply Value By Number of Motors to Determine Total Amps.

ELECTRICAL DATA – RGEA14 SERIES

		042ACT081AA	042ACT08XAA	042ACT101AA	042ACT10XAA	042AJT081AA	042AJT081AB	042AJT08XAA	042AJT08XAB	042AJT101AA
Unit Information	Unit Operating Voltage Range	187-253	187-253	187-253	187-253	187-253	187-253	187-253	187-253	187-253
	Volts	208/230	208/230	208/230	208/230	208/230	208/230	208/230	208/230	208/230
	Phase	3	3	3	3	1	1	1	1	1
	Hz	60	60	60	60	60	60	60	60	60
	Minimum Circuit Ampacity	24	24	24	24	30	30	30	30	30
	Minimum Overcurrent Protection Device Size	25	25	25	25	30	30	30	30	30
	Maximum Overcurrent Protection Device Size	35	35	35	35	45	45	45	45	45
Compressor Motor	No.	1	1	1	1	1	1	1	1	1
	Volts	208/230	208/230	208/230	208/230	208/230	208/230	208/230	208/230	208/230
	Phase	3	3	3	3	1	1	1	1	1
	RPM	3450	3450	3450	3450	3450	3450	3450	3450	3450
	HP, Compressor 1	3 1/2	3 1/2	3 1/2	3 1/2	3 1/2	3 1/2	3 1/2	3 1/2	3 1/2
	Amps (RLA), Comp. 1	13.2	13.2	13.2	13.2	17.9	17.9	17.9	17.9	17.9
	Amps (LRA), Comp. 1	88	88	88	88	112	112	112	112	112
	HP, Compressor 2									
	Amps (RLA), Comp. 2									
Amps (LRA), Comp. 2										
Condenser Motor	No.	1	1	1	1	1	1	1	1	1
	Volts	208/230	208/230	208/230	208/230	208/230	208/230	208/230	208/230	208/230
	Phase	1	1	1	1	1	1	1	1	1
	HP	1/3	1/3	1/3	1/3	1/3	1/3	1/3	1/3	1/3
	Amps (FLA, each)	1.5	1.5	1.5	1.5	1.5	1.5	1.5	1.5	1.5
	Amps (LRA, each)	3	3	3	3	3	3	3	3	3
Evaporator Fan	No.	1	1	1	1	1	1	1	1	1
	Volts	208/230	208/230	208/230	208/230	208/230	208/230	208/230	208/230	208/230
	Phase	1	1	1	1	1	1	1	1	1
	HP	3/4	3/4	3/4	3/4	3/4	3/4	3/4	3/4	3/4
	Amps (FLA, each)	6	6	6	6	6	6	6	6	6
Amps (LRA, each)										

1. Horsepower Per Compressor.
2. Amp Draw Per Motor. Multiply Value By Number of Motors to Determine Total Amps.



ELECTRICAL DATA – RGEA14 SERIES										
		042AJT101AB	042AJT10XAA	042AJT10XAB	048ACT081AA	048ACT08XAA	048ACT101AA	048ACT10XAA	048ADT101AA	048ADT10XAA
Unit Information	Unit Operating Voltage Range	187-253	187-253	187-253	187-253	187-253	187-253	187-253	187-253	187-253
	Volts	208/230	208/230	208/230	208/230	208/230	208/230	208/230	460	460
	Phase	1	1	1	3	3	3	3	3	3
	Hz	60	60	60	60	60	60	60	60	60
	Minimum Circuit Ampacity	30	30	30	25	25	25	25	12	12
	Minimum Overcurrent Protection Device Size	30	30	30	25	25	25	25	35	35
	Maximum Overcurrent Protection Device Size	45	45	45	35	35	35	35	15	15
Compressor Motor	No.	1	1	1	1	1	1	1	1	1
	Volts	208/230	208/230	208/230	208/230	208/230	208/230	208/230	460	460
	Phase	1	1	1	3	3	3	3	3	3
	RPM	3450	3450	3450	3450	3450	3450	3450	3450	3450
	HP, Compressor 1	3 1/2	3 1/2	3 1/2	4	4	4	4	4	4
	Amps (RLA), Comp. 1	17.9	17.9	17.9	13.1	13.1	13.1	13.1	6.1	6.1
	Amps (LRA), Comp. 1	112	112	112	83.1	83.1	83.1	83.1	41	41
	HP, Compressor 2									
	Amps (RLA), Comp. 2									
Amps (LRA), Comp. 2										
Condenser Motor	No.	1	1	1	1	1	1	1	1	1
	Volts	208/230	208/230	208/230	208/230	208/230	208/230	208/230	460	460
	Phase	1	1	1	1	1	1	1	1	1
	HP	1/3	1/3	1/3	1/3	1/3	1/3	1/3	1/3	1/3
	Amps (FLA, each)	1.5	1.5	1.5	2	2	2	2	1	1
	Amps (LRA, each)	3	3	3	3.9	3.9	3.9	3.9	2.2	2.2
Evaporator Fan	No.	1	1	1	1	1	1	1	1	1
	Volts	208/230	208/230	208/230	208/230	208/230	208/230	208/230	460	460
	Phase	1	1	1	1	1	1	1	1	1
	HP	3/4	3/4	3/4	3/4	3/4	3/4	3/4	3/4	3/4
	Amps (FLA, each)	6	6	6	6	6	6	6	3.2	3.2
	Amps (LRA, each)									

1. Horsepower Per Compressor.

2. Amp Draw Per Motor. Multiply Value By Number of Motors to Determine Total Amps.

ELECTRICAL DATA – RGEA14 SERIES

		048AJT081AA	048AJT081AB	048AJT08XAA	048AJT08XAB	048AJT101AA	048AJT101AB	048AJT10XAA	048AJT10XAB
Unit Information	Unit Operating Voltage Range	187-253	187-253	187-253	187-253	187-253	187-253	187-253	187-253
	Volts	208/230	208/230	208/230	208/230	208/230	208/230	208/230	208/230
	Phase	1	1	1	1	1	1	1	1
	Hz	60	60	60	60	60	60	60	60
	Minimum Circuit Ampacity	33	33	33	33	33	33	33	33
	Minimum Overcurrent Protection Device Size	35	35	35	35	35	35	35	35
	Maximum Overcurrent Protection Device Size	50	50	50	50	50	50	50	50
Compressor Motor	No.	1	1	1	1	1	1	1	1
	Volts	208/230	208/230	208/230	208/230	208/230	208/230	208/230	208/230
	Phase	1	1	1	1	1	1	1	1
	RPM	3450	3450	3450	3450	3450	3450	3450	3450
	HP, Compressor 1	4	4	4	4	4	4	4	4
	Amps (RLA), Comp. 1	19.9	19.9	19.9	19.9	19.9	19.9	19.9	19.9
	Amps (LRA), Comp. 1	109	109	109	109	109	109	109	109
	HP, Compressor 2								
	Amps (RLA), Comp. 2								
Amps (LRA), Comp. 2									
Condenser Motor	No.	1	1	1	1	1	1	1	1
	Volts	208/230	208/230	208/230	208/230	208/230	208/230	208/230	208/230
	Phase	1	1	1	1	1	1	1	1
	HP	1/3	1/3	1/3	1/3	1/3	1/3	1/3	1/3
	Amps (FLA, each)	2	2	2	2	2	2	2	2
	Amps (LRA, each)	3.9	3.9	3.9	3.9	3.9	3.9	3.9	3.9
Evaporator Fan	No.	1	1	1	1	1	1	1	1
	Volts	208/230	208/230	208/230	208/230	208/230	208/230	208/230	208/230
	Phase	1	1	1	1	1	1	1	1
	HP	3/4	3/4	3/4	3/4	3/4	3/4	3/4	3/4
	Amps (FLA, each)	6	6	6	6	6	6	6	6
	Amps (LRA, each)								

1. Horsepower Per Compressor.
2. Amp Draw Per Motor. Multiply Value By Number of Motors to Determine Total Amps.

ELECTRICAL DATA – RGEA14 SERIES									
		060ACT101AA	060ACT10XAA	060ADT101AA	060ADT10XAA	060AJT101AA	060AJT101AB	060AJT10XAA	060AJT10XAB
Unit Information	Unit Operating Voltage Range	197-253	197-253	414-506	414-506	197-253	197-253	197-253	197-253
	Volts	208/230	208/230	460	460	208/230	208/230	208/230	208/230
	Phase	3	3	3	3	1	1	1	1
	Hz	60	60	60	60	60	60	60	60
	Minimum Circuit Ampacity	32	32	16	16	41	46	41	46
	Minimum Overcurrent Protection Device Size	35	35	20	20	45	50	45	50
	Maximum Overcurrent Protection Device Size	45	45	20	20	60	70	60	70
Compressor Motor	No.	1	1	1	1	1	1	1	1
	Volts	208/230	208/230	460	460	208/230	208/230	208/230	208/230
	Phase	3	3	3	3	1	1	1	1
	RPM	3500	3500	3500	3500	3500	3450	3500	3450
	HP, Compressor 1	5	5	5	5	5	5	5	5
	Amps (RLA), Comp. 1	17.8	17.8	8.6	8.6	24.4	28.8	24.4	28.8
	Amps (LRA), Comp. 1	110	110	52	52	144.2	152.9	144.2	152.9
	HP, Compressor 2								
	Amps (RLA), Comp. 2								
Amps (LRA), Comp. 2									
Condenser Motor	No.	1	1	1	1	1	1	1	1
	Volts	208/230	208/230	460	460	208/230	208/230	208/230	208/230
	Phase	1	1	1	1	1	1	1	1
	HP	1/3	1/3	1/3	1/3	1/3	1/3	1/3	1/3
	Amps (FLA, each)	2	2	1	1	2	2	2	2
	Amps (LRA, each)	3.9	3.9	2.2	2.2	3.9	3.9	3.9	3.9
Evaporator Fan	No.	1	1	1	1	1	1	1	1
	Volts	208/230	208/230	460	460	208/230	208/230	208/230	208/230
	Phase	1	1	1	1	1	1	1	1
	HP	1	1	1	1	1	1	1	1
	Amps (FLA, each)	7.6	7.6	4	4	7.6	7.6	7.6	7.6
	Amps (LRA, each)								

1. Horsepower Per Compressor.
2. Amp Draw Per Motor. Multiply Value By Number of Motors to Determine Total Amps.

ELECTRICAL DATA – RGEA15 SERIES

		024AJT061AA	024AJT06XAA	024AJT081AA	024AJT08XAA	024AJV061AA	024AJV061AB	024AJV06XAA	024AJV06XAB	024AJV081AA
Unit Information	Unit Operating Voltage Range	187-253	187-253	187-253	187-253	187-253	187-253	187-253	187-253	187-253
	Volts	208/230	208/230	208/230	208/230	208/230	208/230	208/230	208/230	208/230
	Phase	1	1	1	1	1	1	1	1	1
	Hz	60	60	60	60	60	60	60	60	60
	Minimum Circuit Ampacity	19	19	19	19	19	19	19	19	19
	Minimum Overcurrent Protection Device Size	20	20	20	20	25	25	25	25	25
	Maximum Overcurrent Protection Device Size	25	25	25	25	30	30	30	30	30
Compressor Motor	No.	1	1	1	1	1	1	1	1	1
	Volts	208/230	208/230	208/230	208/230	208/230	208/230	208/230	208/230	208/230
	Phase	1	1	1	1	1	1	1	1	1
	RPM	3450	3450	3450	3450	3450	3450	3450	3450	3450
	HP, Compressor 1	2 1/6	2 1/6	2 1/6	2 1/6	2 1/6	2 1/6	2 1/6	2 1/6	2 1/6
	Amps (RLA), Comp. 1	11.2	11.2	11.2	11.2	11.2	11.2	11.2	11.2	11.2
	Amps (LRA), Comp. 1	60.8	60.8	60.8	60.8	60.8	60.8	60.8	60.8	60.8
	HP, Compressor 2									
	Amps (RLA), Comp. 2									
Amps (LRA), Comp. 2										
Condenser Motor	No.	1	1	1	1	1	1	1	1	1
	Volts	208/230	208/230	208/230	208/230	208/230	208/230	208/230	208/230	208/230
	Phase	1	1	1	1	1	1	1	1	1
	HP	1/3	1/3	1/3	1/3	1/3	1/3	1/3	1/3	1/3
	Amps (FLA, each)	1.5	1.5	1.5	1.5	1.5	1.5	1.5	1.5	1.5
	Amps (LRA, each)	3	3	3	3	3	3	3	3	3
Evaporator Fan	No.	1	1	1	1	1	1	1	1	1
	Volts	208/230	208/230	208/230	208/230	208/230	208/230	208/230	208/230	208/230
	Phase	1	1	1	1	1	1	1	1	1
	HP	1/3	1/3	1/3	1/3	1/2	1/2	1/2	1/2	1/2
	Amps (FLA, each)	2.8	2.8	2.8	2.8	3.5	3.5	3.5	3.5	3.5
Amps (LRA, each)										

1. Horsepower Per Compressor.
2. Amp Draw Per Motor. Multiply Value By Number of Motors to Determine Total Amps.

ELECTRICAL DATA – RGEA15 SERIES										
		024AJV081AB	024AJV08XAA	024AJV08XAB	030AJT061AA	030AJT06XAA	030AJT081AA	030AJT08XAA	030AJV061AA	030AJV061AB
Unit Information	Unit Operating Voltage Range	187-253	187-253	187-253	187-253	187-253	187-253	187-253	187-253	187-253
	Volts	208/230	208/230	208/230	208/230	208/230	208/230	208/230	208/230	208/230
	Phase	1	1	1	1	1	1	1	1	1
	Hz	60	60	60	60	60	60	60	60	60
	Minimum Circuit Ampacity	19	19	19	21	21	21	21	21	21
	Minimum Overcurrent Protection Device Size	25	25	25	25	25	25	25	25	25
	Maximum Overcurrent Protection Device Size	30	30	30	30	30	30	30	30	30
Compressor Motor	No.	1	1	1	1	1	1	1	1	1
	Volts	208/230	208/230	208/230	208/230	208/230	208/230	208/230	208/230	208/230
	Phase	1	1	1	1	1	1	1	1	1
	RPM	3450	3450	3450	3450	3450	3450	3450	3450	3450
	HP, Compressor 1	2 1/6	2 1/6	2 1/6	2 2/3	2 2/3	2 2/3	2 2/3	2 2/3	2 2/3
	Amps (RLA), Comp. 1	11.2	11.2	11.2	12.8	12.8	12.8	12.8	12.8	12.8
	Amps (LRA), Comp. 1	60.8	60.8	60.8	64	64	64	64	64	64
	HP, Compressor 2									
	Amps (RLA), Comp. 2									
Amps (LRA), Comp. 2										
Condenser Motor	No.	1	1	1	1	1	1	1	1	1
	Volts	208/230	208/230	208/230	208/230	208/230	208/230	208/230	208/230	208/230
	Phase	1	1	1	1	1	1	1	1	1
	HP	1/3	1/3	1/3	1/3	1/3	1/3	1/3	1/3	1/3
	Amps (FLA, each)	1.5	1.5	1.5	1.5	1.5	1.5	1.5	1.5	1.5
	Amps (LRA, each)	3	3	3	3	3	3	3	3	3
Evaporator Fan	No.	1	1	1	1	1	1	1	1	1
	Volts	208/230	208/230	208/230	208/230	208/230	208/230	208/230	208/230	208/230
	Phase	1	1	1	1	1	1	1	1	1
	HP	1/2	1/2	1/2	1/2	1/2	1/2	1/2	1/2	1/2
	Amps (FLA, each)	3.5	3.5	3.5	2.8	2.8	2.8	2.8	3.5	3.5
	Amps (LRA, each)									

1. Horsepower Per Compressor.

2. Amp Draw Per Motor. Multiply Value By Number of Motors to Determine Total Amps.

ELECTRICAL DATA – RGEA15 SERIES

		030AJV06XAA	030AJV06XAB	030AJV081AA	030AJV081AB	030AJV08XAA	030AJV08XAB	036ACT061AA	036ACT06XAA	036ACT081AA
Unit Information	Unit Operating Voltage Range	187-253	187-253	187-253	187-253	187-253	187-253	187-253	187-253	187-253
	Volts	208/230	208/230	208/230	208/230	208/230	208/230	208/230	208/230	208/230
	Phase	1	1	1	1	1	1	3	3	3
	Hz	60	60	60	60	60	60	60	60	60
	Minimum Circuit Ampacity	21	21	21	21	21	21	17	17	17
	Minimum Overcurrent Protection Device Size	25	25	25	25	25	25	20	20	20
	Maximum Overcurrent Protection Device Size	30	30	30	30	30	30	25	25	25
Compressor Motor	No.	1	1	1	1	1	1	1	1	1
	Volts	208/230	208/230	208/230	208/230	208/230	208/230	208/230	208/230	208/230
	Phase	1	1	1	1	1	1	3	3	3
	RPM	3450	3450	3450	3450	3450	3450	3450	3450	3450
	HP, Compressor 1	2 2/3	2 2/3	2 2/3	2 2/3	2 2/3	2 2/3	3 1/3	3 1/3	3 1/3
	Amps (RLA), Comp. 1	12.8	12.8	12.8	12.8	12.8	12.8	9	9	9
	Amps (LRA), Comp. 1	64	64	64	64	64	64	71	71	71
	HP, Compressor 2									
	Amps (RLA), Comp. 2									
Amps (LRA), Comp. 2										
Condenser Motor	No.	1	1	1	1	1	1	1	1	1
	Volts	208/230	208/230	208/230	208/230	208/230	208/230	208/230	208/230	208/230
	Phase	1	1	1	1	1	1	1	1	1
	HP	1/3	1/3	1/3	1/3	1/3	1/3	1/3	1/3	1/3
	Amps (FLA, each)	1.5	1.5	1.5	1.5	1.5	1.5	1.5	1.5	1.5
	Amps (LRA, each)	3	3	3	3	3	3	3	3	3
Evaporator Fan	No.	1	1	1	1	1	1	1	1	1
	Volts	208/230	208/230	208/230	208/230	208/230	208/230	208/230	208/230	208/230
	Phase	1	1	1	1	1	1	1	1	1
	HP	1/2	1/2	1/2	1/2	1/2	1/2	1/2	1/2	1/2
	Amps (FLA, each)	3.5	3.5	3.5	3.5	3.5	3.5	4.1	4.1	4.1
Amps (LRA, each)										

1. Horsepower Per Compressor.
2. Amp Draw Per Motor. Multiply Value By Number of Motors to Determine Total Amps.

ELECTRICAL DATA – RGEA15 SERIES										
		036ACT08XAA	036ACT101AA	036ACT10XAA	036ADT061AA	036ADT06XAA	036ADT081AA	036ADT08XAA	036ADT101AA	036ADT10XAA
Unit Information	Unit Operating Voltage Range	187-253	187-253	187-253	414-506	414-506	414-506	414-506	414-506	414-506
	Volts	208/230	208/230	208/230	460	460	460	460	460	460
	Phase	3	3	3	3	3	3	3	3	3
	Hz	60	60	60	60	60	60	60	60	60
	Minimum Circuit Ampacity	17	17	17	10	10	10	10	10	10
	Minimum Overcurrent Protection Device Size	20	20	20	15	15	15	15	15	15
	Maximum Overcurrent Protection Device Size	25	25	25	15	15	15	15	15	15
Compressor Motor	No.	1	1	1	1	1	1	1	1	1
	Volts	208/230	208/230	208/230	460	460	460	460	460	460
	Phase	3	3	3	3	3	3	3	3	3
	RPM	3450	3450	3450	3450	3450	3450	3450	3450	3450
	HP, Compressor 1	3 1/3	3 1/3	3 1/3	3 1/3	3 1/3	3 1/3	3 1/3	3 1/3	3 1/3
	Amps (RLA), Comp. 1	9	9	9	5.6	5.6	5.6	5.6	5.6	5.6
	Amps (LRA), Comp. 1	71	71	71	38	38	38	38	38	38
	HP, Compressor 2									
	Amps (RLA), Comp. 2									
Amps (LRA), Comp. 2										
Condenser Motor	No.	1	1	1	1	1	1	1	1	1
	Volts	208/230	208/230	208/230	460	460	460	460	460	460
	Phase	1	1	1	1	1	1	1	1	1
	HP	1/3	1/3	1/3	1/3	1/3	1/3	1/3	1/3	1/3
	Amps (FLA, each)	1.5	1.5	1.5	0.8	0.8	0.8	0.8	0.8	0.8
	Amps (LRA, each)	3	3	3	1.6	1.6	1.6	1.6	1.6	1.6
Evaporator Fan	No.	1	1	1	1	1	1	1	1	1
	Volts	208/230	208/230	208/230	460/460	460/460	460/460	460/460	460/460	460/460
	Phase	1	1	1	1	1	1	1	1	1
	HP	1/2	1/2	1/2	1/2	1/2	1/2	1/2	1/2	1/2
	Amps (FLA, each)	4.1	4.1	4.1	2.1	2.1	2.1	2.1	2.1	2.1
	Amps (LRA, each)									

1. Horsepower Per Compressor.

2. Amp Draw Per Motor. Multiply Value By Number of Motors to Determine Total Amps.

ELECTRICAL DATA – RGEA15 SERIES

		036AJT061AA	036AJT06XAA	036AJT081AA	036AJT08XAA	036AJT101AA	036AJT10XAA	036AJV061AA	036AJV061AB	036AJV06XAA
Unit Information	Unit Operating Voltage Range	187-253	187-253	187-253	187-253	187-253	187-253	187-253	187-253	187-253
	Volts	208/230	208/230	208/230	208/230	208/230	208/230	208/230	208/230	208/230
	Phase	1	1	1	1	1	1	1	1	1
	Hz	60	60	60	60	60	60	60	60	60
	Minimum Circuit Ampacity	24	24	24	24	24	24	23	23	23
	Minimum Overcurrent Protection Device Size	25	25	25	25	25	25	30	30	30
	Maximum Overcurrent Protection Device Size	35	35	35	35	35	35	35	35	35
Compressor Motor	No.	1	1	1	1	1	1	1	1	1
	Volts	208/230	208/230	208/230	208/230	208/230	208/230	208/230	208/230	208/230
	Phase	1	1	1	1	1	1	1	1	1
	RPM	3450	3450	3450	3450	3450	3450	3450	3450	3450
	HP, Compressor 1	3 1/3	3 1/3	3 1/3	3 1/3	3 1/3	3 1/3	3 1/3	3 1/3	3 1/3
	Amps (RLA), Comp. 1	14.1	14.1	14.1	14.1	14.1	14.1	14.1	14.1	14.1
	Amps (LRA), Comp. 1	77	77	77	77	77	77	77	77	77
	HP, Compressor 2									
	Amps (RLA), Comp. 2									
Amps (LRA), Comp. 2										
Condenser Motor	No.	1	1	1	1	1	1	1	1	1
	Volts	208/230	208/230	208/230	208/230	208/230	208/230	208/230	208/230	208/230
	Phase	1	1	1	1	1	1	1	1	1
	HP	1/3	1/3	1/3	1/3	1/3	1/3	1/3	1/3	1/3
	Amps (FLA, each)	1.5	1.5	1.5	1.5	1.5	1.5	1.5	1.5	1.5
	Amps (LRA, each)	3	3	3	3	3	3	3	3	3
Evaporator Fan	No.	1	1	1	1	1	1	1	1	1
	Volts	208/230	208/230	208/230	208/230	208/230	208/230	208/230	208/230	208/230
	Phase	1	1	1	1	1	1	1	1	1
	HP	1/2	1/2	1/2	1/2	1/2	1/2	1/2	1/2	1/2
	Amps (FLA, each)	4.1	4.1	4.1	4.1	4.1	4.1	3.5	3.5	3.5
Amps (LRA, each)										

1. Horsepower Per Compressor.
2. Amp Draw Per Motor. Multiply Value By Number of Motors to Determine Total Amps.

ELECTRICAL DATA – RGEA15 SERIES										
		036AJV06XAB	036AJV081AA	036AJV081AB	036AJV08XAA	036AJV08XAB	036AJV101AA	036AJV101AB	036AJV10XAA	036AJV10XAB
Unit Information	Unit Operating Voltage Range	187-253	187-253	187-253	187-253	187-253	187-253	187-253	187-253	187-253
	Volts	208/230	208/230	208/230	208/230	208/230	208/230	208/230	208/230	208/230
	Phase	1	1	1	1	1	1	1	1	1
	Hz	60	60	60	60	60	60	60	60	60
	Minimum Circuit Ampacity	23	24	24	24	24	24	24	24	24
	Minimum Overcurrent Protection Device Size	30	30	30	30	30	30	30	30	30
	Maximum Overcurrent Protection Device Size	35	35	35	35	35	35	35	35	35
Compressor Motor	No.	1	1	1	1	1	1	1	1	1
	Volts	208/230	208/230	208/230	208/230	208/230	208/230	208/230	208/230	208/230
	Phase	1	1	1	1	1	1	1	1	1
	RPM	3450	3450	3450	3450	3450	3450	3450	3450	3450
	HP, Compressor 1	3 1/3	3 1/3	3 1/3	3 1/3	3 1/3	3 1/3	3 1/3	3 1/3	3 1/3
	Amps (RLA), Comp. 1	14.1	14.1	14.1	14.1	14.1	14.1	14.1	14.1	14.1
	Amps (LRA), Comp. 1	77	77	77	77	77	77	77	77	77
	HP, Compressor 2									
	Amps (RLA), Comp. 2									
Amps (LRA), Comp. 2										
Condenser Motor	No.	1	1	1	1	1	1	1	1	1
	Volts	208/230	208/230	208/230	208/230	208/230	208/230	208/230	208/230	208/230
	Phase	1	1	1	1	1	1	1	1	1
	HP	1/3	1/3	1/3	1/3	1/3	1/3	1/3	1/3	1/3
	Amps (FLA, each)	1.5	1.5	1.5	1.5	1.5	1.5	1.5	1.5	1.5
	Amps (LRA, each)	3	3	3	3	3	3	3	3	3
Evaporator Fan	No.	1	1	1	1	1	1	1	1	1
	Volts	208/230	208/230	208/230	208/230	208/230	208/230	208/230	208/230	208/230
	Phase	1	1	1	1	1	1	1	1	1
	HP	1/2	3/4	3/4	3/4	3/4	3/4	3/4	3/4	3/4
	Amps (FLA, each)	3.5	4	4	4	4	4	4	4	4
	Amps (LRA, each)									

1. Horsepower Per Compressor.

2. Amp Draw Per Motor. Multiply Value By Number of Motors to Determine Total Amps.

ELECTRICAL DATA – RGEA15 SERIES

		042ACT081AA	042ACT08XAA	042ACT101AA	042ACT10XAA	042AJV081AA	042AJV081AB	042AJV08XAA	042AJV08XAB	042AJV101AA
Unit Information	Unit Operating Voltage Range	187-253	187-253	187-253	187-253	187-253	187-253	187-253	187-253	187-253
	Volts	208/230	208/230	208/230	208/230	208/230	208/230	208/230	208/230	208/230
	Phase	3	3	3	3	1	1	1	1	1
	Hz	60	60	60	60	60	60	60	60	60
	Minimum Circuit Ampacity	24	24	24	24	28	28	28	28	28
	Minimum Overcurrent Protection Device Size	25	25	25	25	35	35	35	35	35
	Maximum Overcurrent Protection Device Size	35	35	35	35	45	45	45	45	45
Compressor Motor	No.	1	1	1	1	1	1	1	1	1
	Volts	208/230	208/230	208/230	208/230	208/230	208/230	208/230	208/230	208/230
	Phase	3	3	3	3	1	1	1	1	1
	RPM	3450	3450	3450	3450	3450	3450	3450	3450	3450
	HP, Compressor 1	3 1/2	3 1/2	3 1/2	3 1/2	3 1/2	3 1/2	3 1/2	3 1/2	3 1/2
	Amps (RLA), Comp. 1	13.2	13.2	13.2	13.2	17.9	17.9	17.9	17.9	17.9
	Amps (LRA), Comp. 1	88	88	88	88	112	112	112	112	112
	HP, Compressor 2									
	Amps (RLA), Comp. 2									
Amps (LRA), Comp. 2										
Condenser Motor	No.	1	1	1	1	1	1	1	1	1
	Volts	208/230	208/230	208/230	208/230	208/230	208/230	208/230	208/230	208/230
	Phase	1	1	1	1	1	1	1	1	1
	HP	1/3	1/3	1/3	1/3	1/3	1/3	1/3	1/3	1/3
	Amps (FLA, each)	1.5	1.5	1.5	1.5	1.5	1.5	1.5	1.5	1.5
	Amps (LRA, each)	3	3	3	3	3	3	3	3	3
Evaporator Fan	No.	1	1	1	1	1	1	1	1	1
	Volts	208/230	208/230	208/230	208/230	208/230	208/230	208/230	208/230	208/230
	Phase	1	1	1	1	1	1	1	1	1
	HP	3/4	3/4	3/4	3/4	3/4	3/4	3/4	3/4	3/4
	Amps (FLA, each)	6	6	6	6	4	4	4	4	4
Amps (LRA, each)										

1. Horsepower Per Compressor.
2. Amp Draw Per Motor. Multiply Value By Number of Motors to Determine Total Amps.



ELECTRICAL DATA – RGEA15 SERIES										
		042AJV101AB	042AJV10XAA	042AJV10XAB	048ACT081AA	048ACT08XAA	048ACT101AA	048ACT10XAA	048ADT101AA	048ADT10XAA
Unit Information	Unit Operating Voltage Range	187-253	187-253	187-253	187-253	187-253	187-253	187-253	414-506	414-506
	Volts	208/230	208/230	208/230	208/230	208/230	208/230	208/230	460	460
	Phase	1	1	1	3	3	3	3	3	3
	Hz	60	60	60	60	60	60	60	60	60
	Minimum Circuit Ampacity	28	28	28	25	25	25	25	12	12
	Minimum Overcurrent Protection Device Size	35	35	35	25	25	25	25	35	35
	Maximum Overcurrent Protection Device Size	45	45	45	35	35	35	35	15	15
Compressor Motor	No.	1	1	1	1	1	1	1	1	1
	Volts	208/230	208/230	208/230	208/230	208/230	208/230	208/230	460	460
	Phase	1	1	1	3	3	3	3	1	1
	RPM	3450	3450	3450	3450	3450	3450	3450	3450	3450
	HP, Compressor 1	3 1/2	3 1/2	3 1/2	4	4	4	4	4	4
	Amps (RLA), Comp. 1	17.9	17.9	17.9	13.1	13.1	13.1	13.1	6.1	6.1
	Amps (LRA), Comp. 1	112	112	112	83.1	83.1	83.1	83.1	43	43
	HP, Compressor 2									
	Amps (RLA), Comp. 2									
Amps (LRA), Comp. 2										
Condenser Motor	No.	1	1	1	1	1	1	1	1	1
	Volts	208/230	208/230	208/230	208/230	208/230	208/230	208/230	460	460
	Phase	1	1	1	1	1	1	1	1	1
	HP	1/3	1/3	1/3	1/3	1/3	1/3	1/3	1/3	1/3
	Amps (FLA, each)	1.5	1.5	1.5	2	2	2	2	1	1
	Amps (LRA, each)	3	3	3	3.9	3.9	3.9	3.9	3.9	3.9
Evaporator Fan	No.	1	1	1	1	1	1	1	1	1
	Volts	208/230	208/230	208/230	208/230	208/230	208/230	208/230	460	460
	Phase	1	1	1	1	1	1	1	1	1
	HP	3/4	3/4	3/4	3/4	3/4	3/4	3/4	3/4	3/4
	Amps (FLA, each)	4	4	4	6	6	6	6	3.2	3.2
	Amps (LRA, each)									

1. Horsepower Per Compressor.

2. Amp Draw Per Motor. Multiply Value By Number of Motors to Determine Total Amps.

ELECTRICAL DATA – RGEA15 SERIES

		048AJT10XAA	048AJV081AA	048AJV081AB	048AJV08XAA	048AJV08XAB	048AJV101AA	048AJV101AB	048AJV10XAA	048AJV10XAB
Unit Information	Unit Operating Voltage Range	187-253	187-253	187-253	187-253	187-253	187-253	187-253	187-253	187-253
	Volts	208/230	208/230	208/230	208/230	208/230	208/230	208/230	208/230	208/230
	Phase	1	1	1	1	1	1	1	1	1
	Hz	60	60	60	60	60	60	60	60	60
	Minimum Circuit Ampacity	33	34	34	34	34	34	34	34	34
	Minimum Overcurrent Protection Device Size	35	40	40	40	40	40	40	40	40
	Maximum Overcurrent Protection Device Size	50	50	50	50	50	50	50	50	50
Compressor Motor	No.	1	1	1	1	1	1	1	1	1
	Volts	208/230	208/230	208/230	208/230	208/230	208/230	208/230	208/230	208/230
	Phase	1	1	1	1	1	1	1	1	1
	RPM	3450	3450	3450	3450	3450	3450	3450	3450	3450
	HP, Compressor 1	4	4	4	4	4	4	4	4	4
	Amps (RLA), Comp. 1	19.9	19.9	19.9	19.9	19.9	19.9	19.9	19.9	19.9
	Amps (LRA), Comp. 1	109	109	109	109	109	109	109	109	109
	HP, Compressor 2									
	Amps (RLA), Comp. 2									
Amps (LRA), Comp. 2										
Condenser Motor	No.	1	1	1	1	1	1	1	1	1
	Volts	208/230	208/230	208/230	208/230	208/230	208/230	208/230	208/230	208/230
	Phase	1	1	1	1	1	1	1	1	1
	HP	1/3	1/3	1/3	1/3	1/3	1/3	1/3	1/3	1/3
	Amps (FLA, each)	2	2	2	2	2	2	2	2	2
	Amps (LRA, each)	3.9	3.9	3.9	3.9	3.9	3.9	3.9	3.9	3.9
Evaporator Fan	No.	1	1	1	1	1	1	1	1	1
	Volts	208/230	208/230	208/230	208/230	208/230	208/230	208/230	208/230	208/230
	Phase	1	1	1	1	1	1	1	1	1
	HP	3/4	1	1	1	1	1	1	1	1
	Amps (FLA, each)	6	6.8	6.8	6.8	6.8	6.8	6.8	6.8	6.8
Amps (LRA, each)										

1. Horsepower Per Compressor.
2. Amp Draw Per Motor. Multiply Value By Number of Motors to Determine Total Amps.

ELECTRICAL DATA – RGEA15 SERIES								
		060ACT101AA	060ADT101AA	060ADT10XAA	060AJT101AA	060AJT10XAA	060AJV101AB	060AJV10XAB
Unit Information	Unit Operating Voltage Range	197-253	414-506	414-506	197-253	197-253	197-253	197-253
	Volts	208/230	460	460	208/230	208/230	208/230	208/230
	Phase	3	3	3	1	1	1	1
	Hz	60	60	60	60	60	60	60
	Minimum Circuit Ampacity	30	15	15	46	46	45	45
	Minimum Overcurrent Protection Device Size	50	20	20	50	50	60	60
	Maximum Overcurrent Protection Device Size	45	20	20	70	70	70	70
Compressor Motor	No.	1	1	1	1	1	1	1
	Volts	208/230	460	460	208/230	208/230	208/230	208/230
	Phase	3	3	3	1	1	1	1
	RPM	3450	3450	3450	3450	3450	3450	3450
	HP, Compressor 1	5	5	5	5	5	5	5
	Amps (RLA), Comp. 1	16.2	7.6	7.6	28.8	28.8	28.8	28.8
	Amps (LRA), Comp. 1	110	52	52	152.9	152.9	152.9	152.9
	HP, Compressor 2							
	Amps (RLA), Comp. 2							
Amps (LRA), Comp. 2								
Condenser Motor	No.	1	1	1	1	1	1	1
	Volts	208/230	460	460	208/230	208/230	208/230	208/230
	Phase	1	1	1	1	1	1	1
	HP	1/3	1/3	1/3	1/3	1/3	1/3	1/3
	Amps (FLA, each)	2	1	1	2	2	2	2
	Amps (LRA, each)	3.9	2.2	2.2	3.9	3.9	3.9	3.9
Evaporator Fan	No.	1	1	1	1	1	1	1
	Volts	208/230	460/460	460/460	208/230	208/230	208/230	208/230
	Phase	1	1	1	1	1	1	1
	HP	1	1	1	1	1	1	1
	Amps (FLA, each)	7.6	4	4	7.6	7.6	6.8	6.8
	Amps (LRA, each)							

1. Horsepower Per Compressor.

2. Amp Draw Per Motor. Multiply Value By Number of Motors to Determine Total Amps.

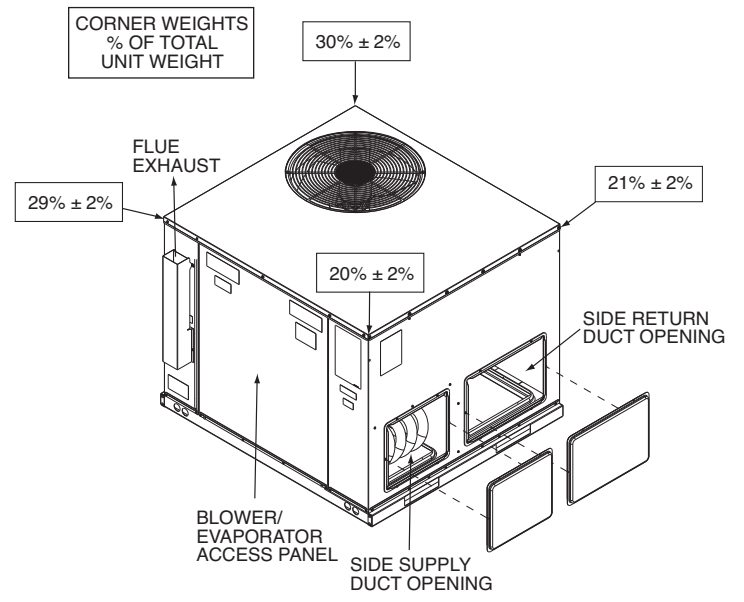
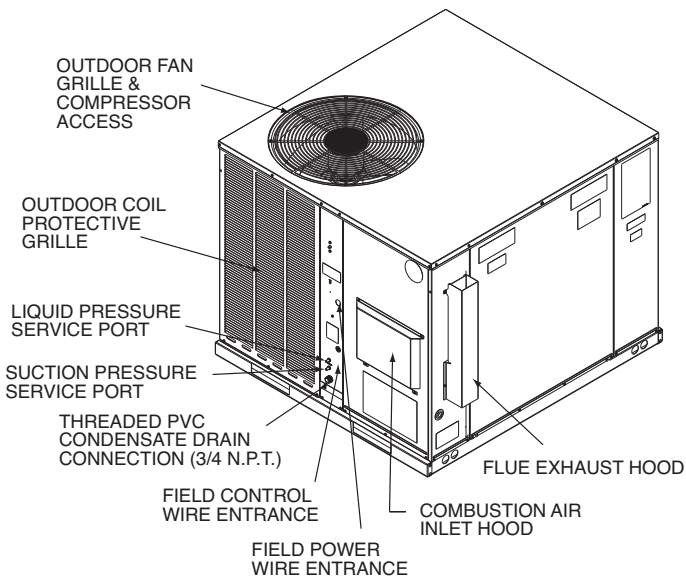

TOP VIEW

BOTTOM VIEW

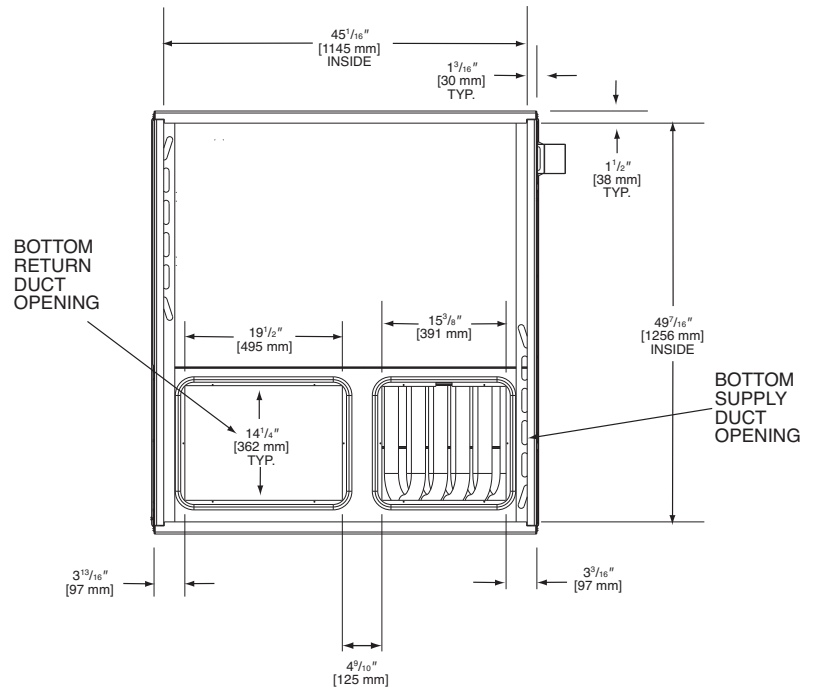
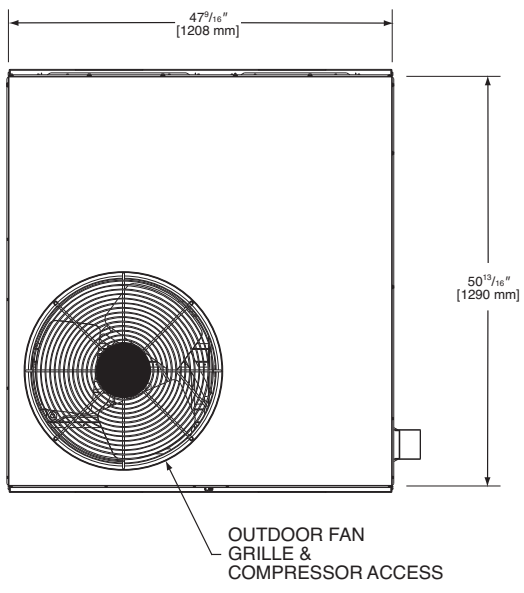

[] Designates Metric Conversions

SIDE VIEW

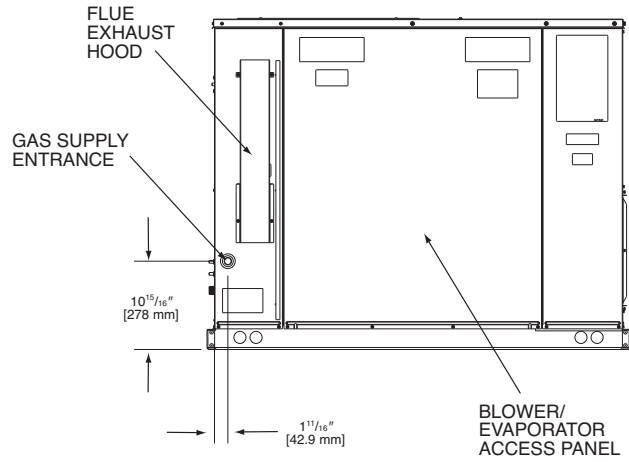

SIDE VIEW

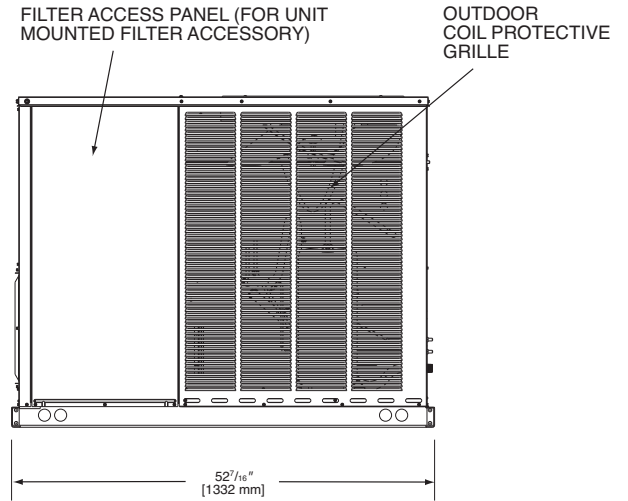

FRONT VIEW

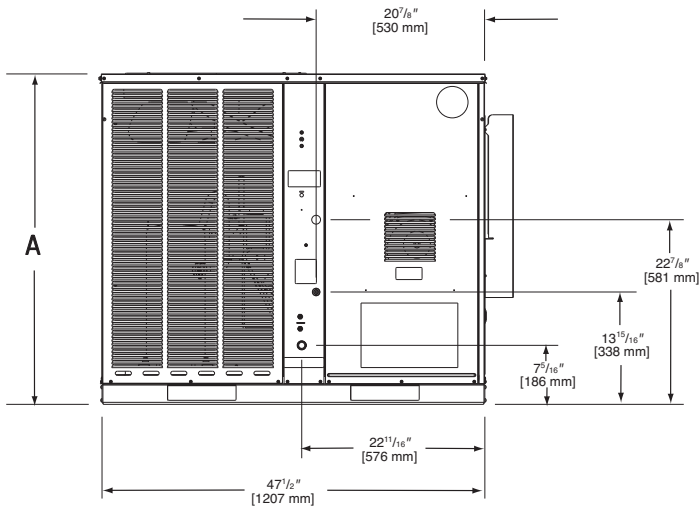

BACK VIEW

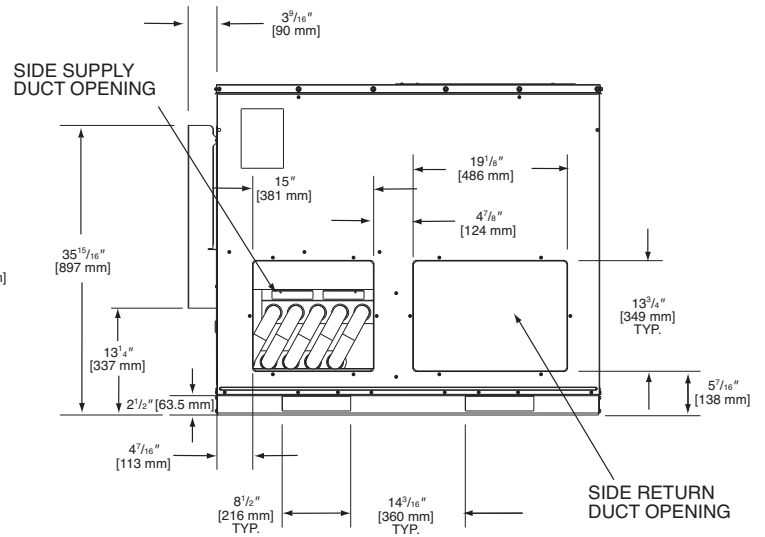

SHOWN WITH DUCT COVERS REMOVED.

Models RGEA 14/15	Height "A"
024, 030, 036, 042	$35^{15/16}$ "
048, 060	41"

[] Designates Metric Conversions

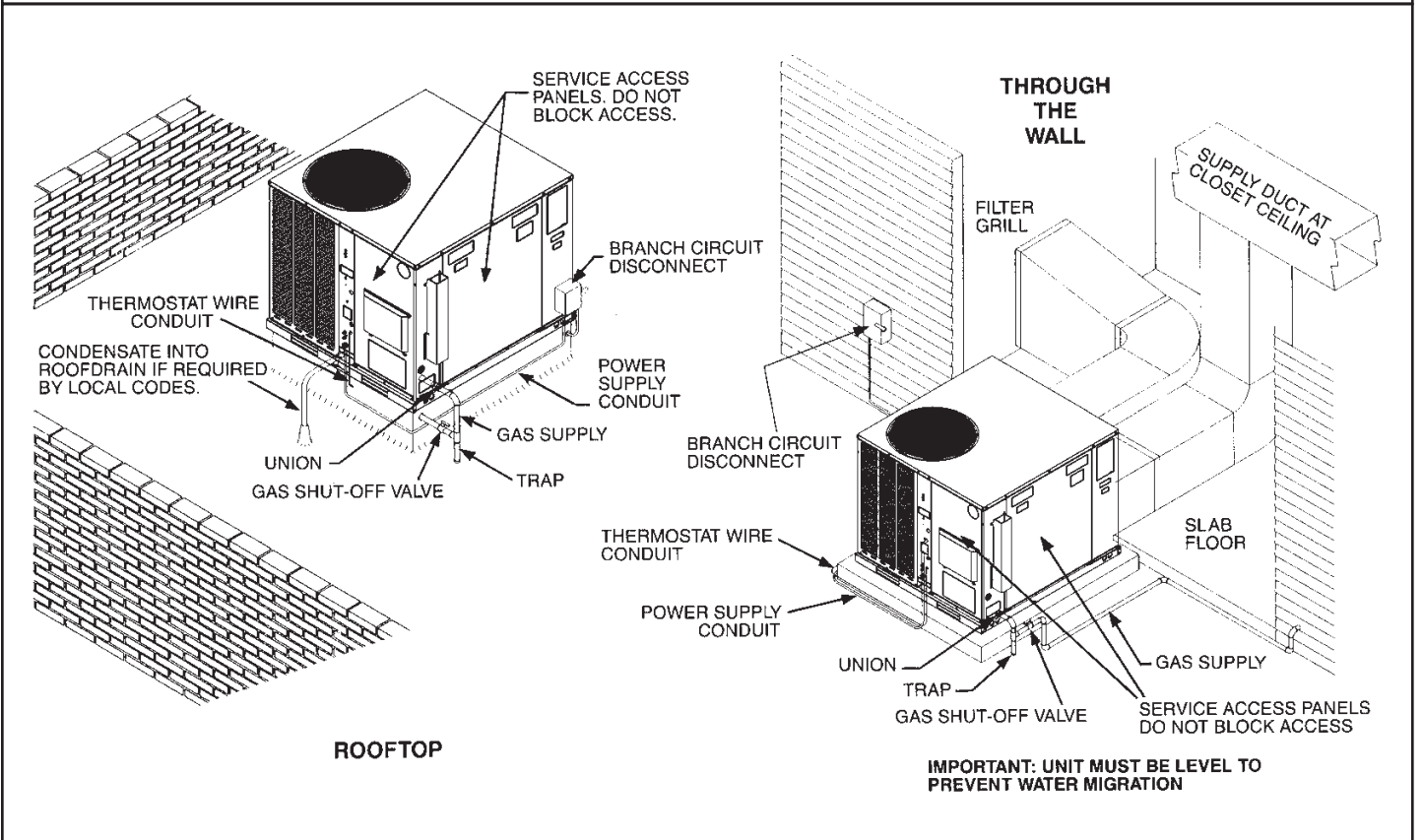
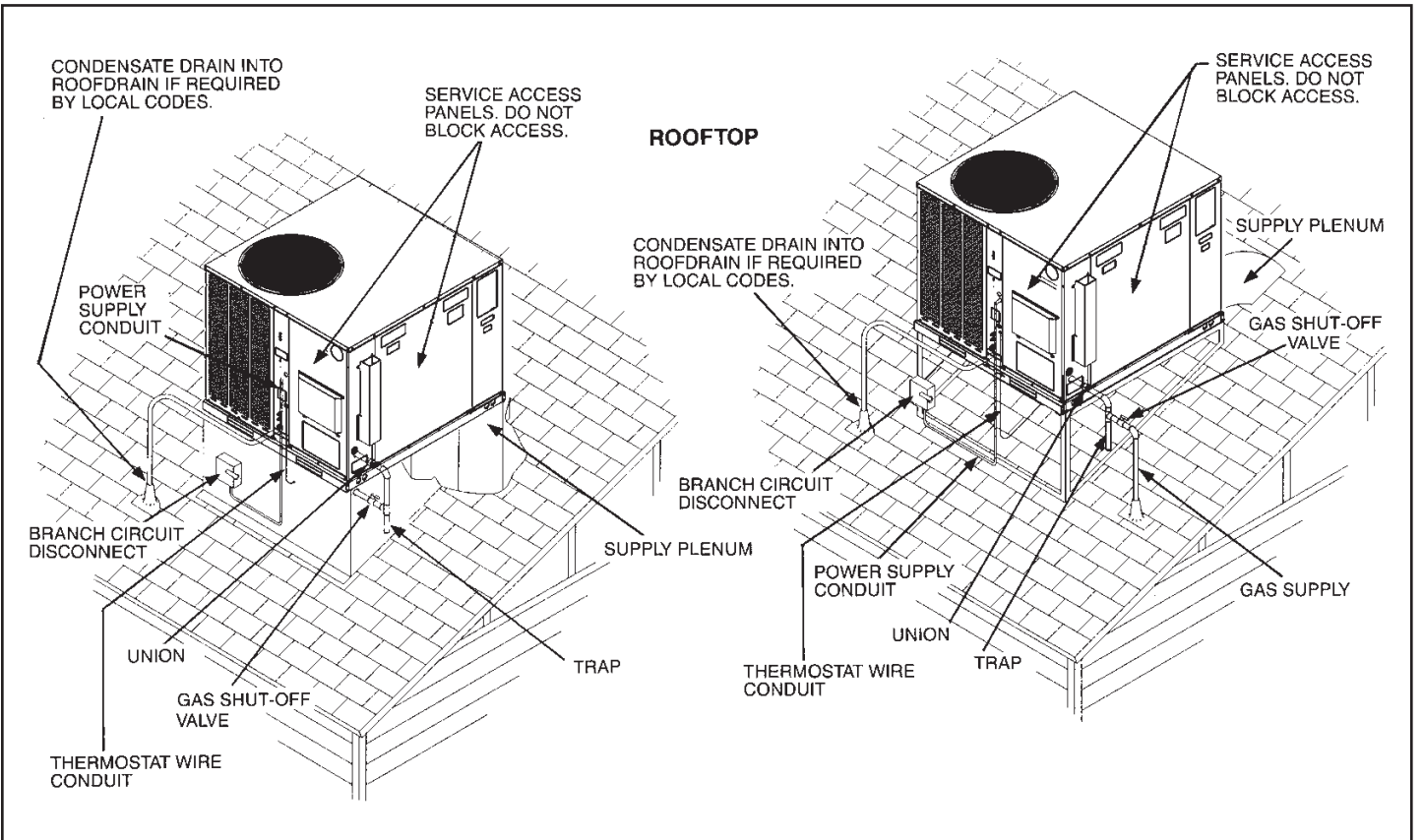

[] Designates Metric Conversions

ACCESSORY EQUIPMENT

Accessory Description	Model Application	Accessory Model No.
Roofcurbs	RGEA14/15	RXSG-AAA08 (8" [203 mm] Height) RXSG-AAA14 (14" [356 mm] Height) RXSG-AAA24 (24" [610 mm] Height)
Supply & Return Diffusers	RGEA14/15	RXRN-BD15
Economizers (Sideflow Only)	RGEA14/15	AXRE-CCA30 (3 Position) AXRD-CCM10 (Fully Modulating)
Economizers (Downflow Only)	RGEA14/15	AXRE-CAA30 (3 Position) AXRD-CAM10 (Fully Modulating)
Fresh Air Damper	RGEA14/15	AXRF-FAB1 (Motorized-35%) AXRF-FAA1 (Fixed-35%)
Rectangular to Round Transition (Downflow)	RGEA14/15	RXMC-CA02 (16" [406 mm] Ducts) RXMC-CA03 (18" [457 mm] Ducts)
Filter Kit	RGEA14/15	RXRY-B01
Sideflow Rectangular to Round Transition	RGEA14/15	RXMC-BA01
LP Conversion Kits	RGEA14/15	RXGJ-EP84W (White-Rodgers Gas Valve) RXGJ-EP85H (Honeywell Gas Valve) RXGJ-FP28
Low Ambient Control	RGEA14/15	RXRZ-B01
High Pressure Control	RGEA14/15 ²	RXAB-E01
Low Pressure Control	RGEA14/15 ²	RXAC-C01
Canadian High Altitude Kit (for Natural Gas only ¹)	RGEA14/15	RXR- AH01

¹ If a particular unit is to be converted to operate on LP (propane) for elevations above 2000 ft. [609.6 m] in Canada, the existing Natural Gas to LP Conversion Kits for the subject models already contain the necessary orifices and instructions to de-rate the input for 2000-4500 ft. [609.6-1371.6 m] Canadian applications.

² High pressure switches are standard for RGEA15 Models.

[] Designates Metric Conversions

COMMON SUPPLY/RETURN CONCENTRIC AIR DIFFUSER

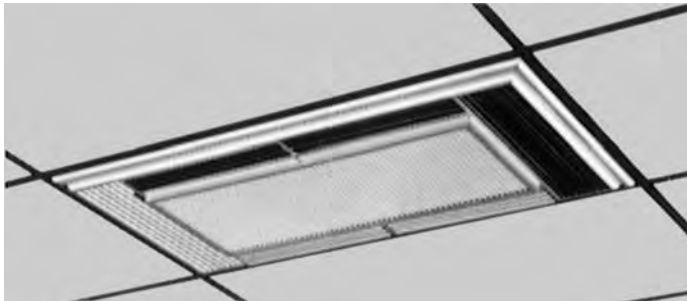

SUPPLY/RETURN DIFFUSER

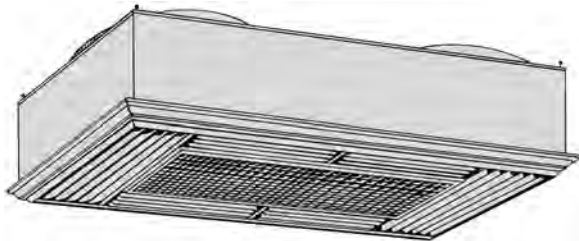

Designed to convert a side by side or an over and under arrangement into a concentric distribution of air. The diffuser is flush mounted, completely insulated, assembled, and internally baffled to provide four way supply air distribution with a center return. To make the assembly complete and ready to fit into a 2' [0.61 m] x 4' [1.22 m] suspended ceiling grid, the diffuser includes adjustable supply louvers, hanging rings, anti-sweat gasket, and round flanges for use with flexible ducts.

Model No.	Diameter Inches [mm]	Shipping Wt. Lbs. [kg]	Dimension A Inches [mm]
RXRN-BD15	16 [406]	90 [40.82]	20 1/2 [521]

DIFFUSER INSTALLS FLUSH WITH CEILING

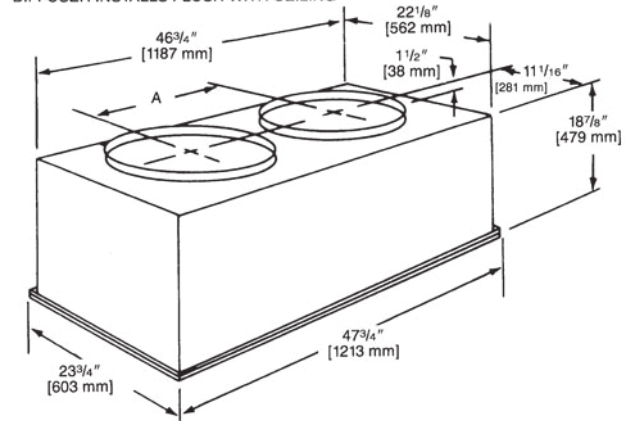

NOTE: The location of the combination supply and return diffuser should not exceed 10 feet [3.05 m] above the floor level for units @ 1000 CFM [472 L/s] or less and 12 [3.66 m] to 14 feet [4.27 m] above the floor level for units with CFM greater than 1000 [472 L/s]. If the diffuser is installed with a greater distance than recommended above, the supply air may become stratified above the required comfort area causing uncomfortable conditions.

AIRFLOW/PRESSURE DROP INFORMATION (INCHES W.C. [kPa])

Accessory	Approximate CFM [L/s]-Supply Air			
	1300 [614]	1575 [743]	1800 [850]	2200 [1038]
Plenum & Supply/Return Duct	.07 [.017]	.10 [.024]	.12 [.030]	.17 [.042]
Diffuser	.09 [.022]	.13 [.032]	.16 [.040]	.24 [.060]
Economizer	.06 [.015]	.09 [.022]	.11 [.027]	.17 [.042]

SUPPLY AIR/PERFORMANCE

Diffuser Airflow CFM [L/s]	Range of Throw Ft. [m]
800 [378]-1200 [566]	14 [4.27]-16 [4.88]
1600 [755]-2000 [944]	18 [5.49]-28 [8.53]

DUCT ADAPTERS RECTANGULAR TO ROUND TRANSITIONS (DOWNFLOW)

RXMC-CA02

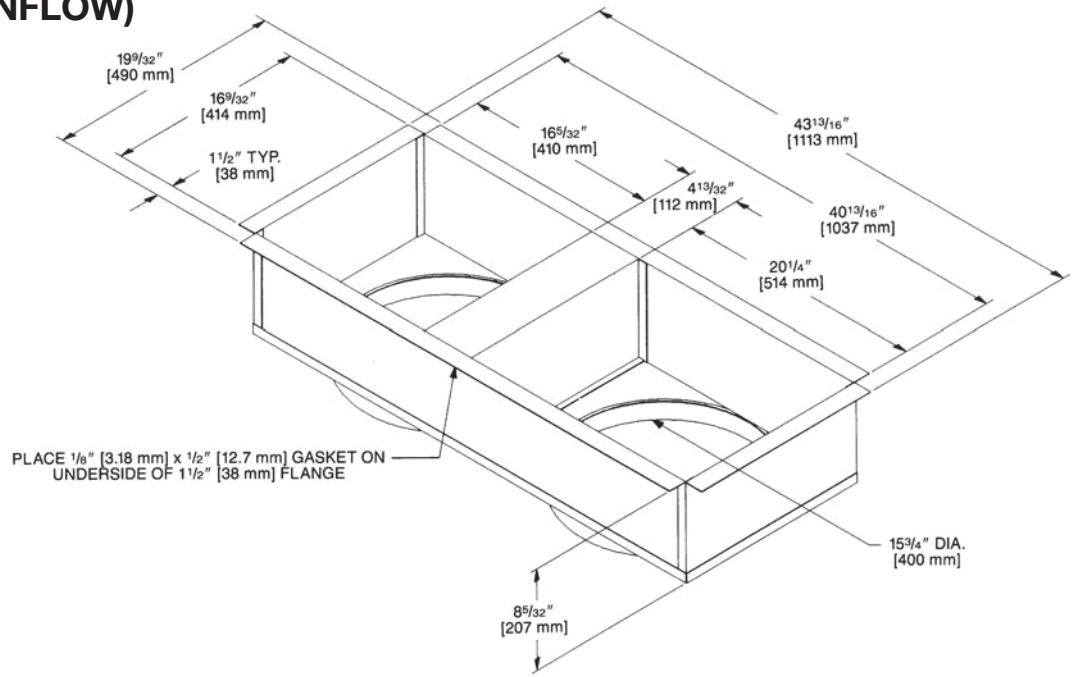

RXMC-CA03

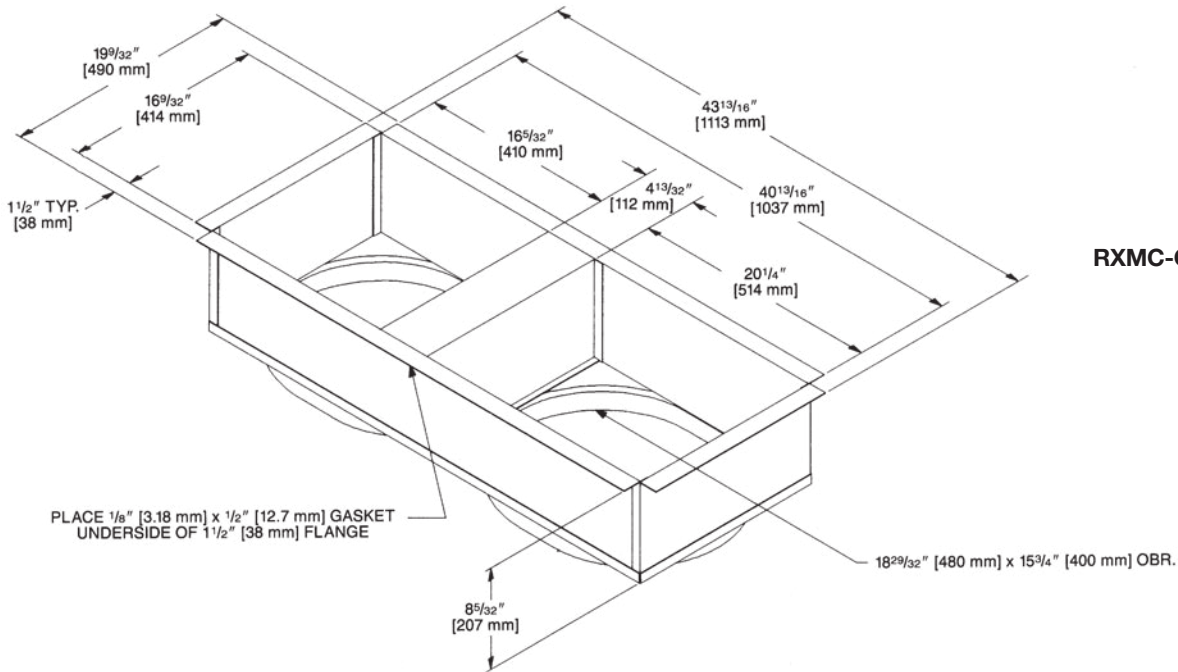

[] Designates Metric Conversions

FRESH AIR DAMPER

AXRF-FAA1 (Fixed - 0-35%)

The 0-35% manual outside Air Damper is designed to replace the unit return air duct cover. No drilling or damper assembly is required. The amount of outside air (0-35%) is controlled by simply adjusting the side damper.

AXRF-FAB1 (Motorized - 0-35%)

The 0-35% motorized outside Air Damper is designed to replace the unit return air duct cover. No drilling or damper assembly is required. The control motor opens the adjustable slide damper when the unit blower motor is energized.

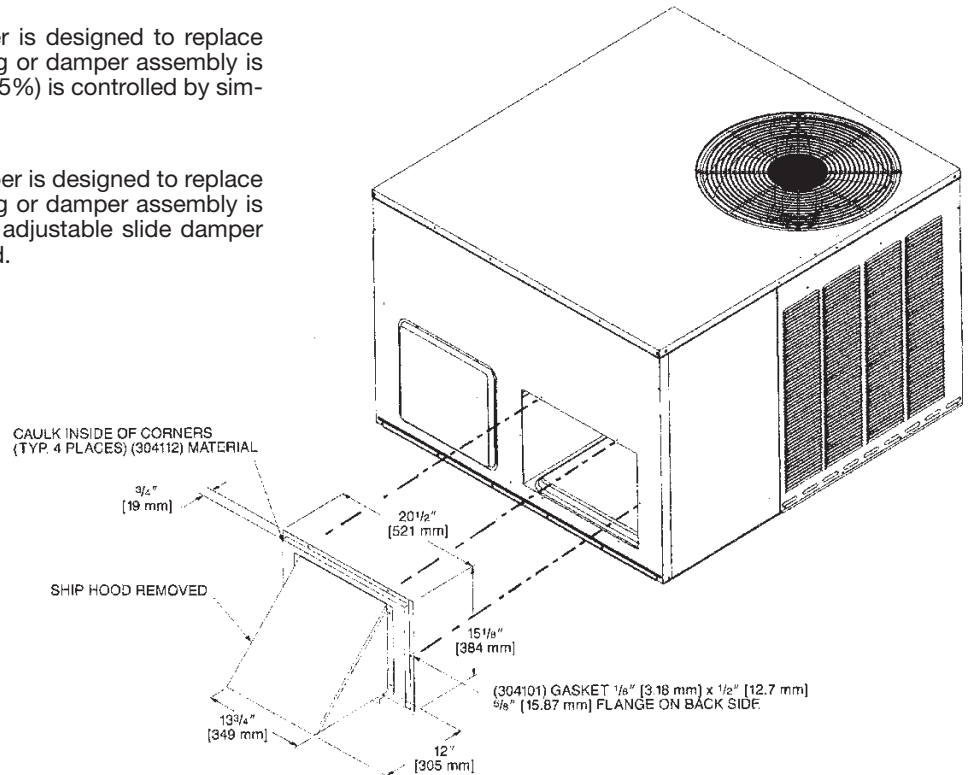

ECONOMIZERS

RXRE-CAA30 (3 Position) and RXRD-CAM10 (Fully Modulating)

AXRE-CAA30 (3 Position)

Provided with enthalpy control, and mixed air sensor. Settings include fully open, fully closed and adjustable mid point.

AXRD-CAM10 (Fully Modulating)

Provided with enthalpy control, mixed air sensor and minimum position potentiometer for proportioning (modulating) the amount of fresh air.

NOTE: See economizer installation instructions for correct filter access door.

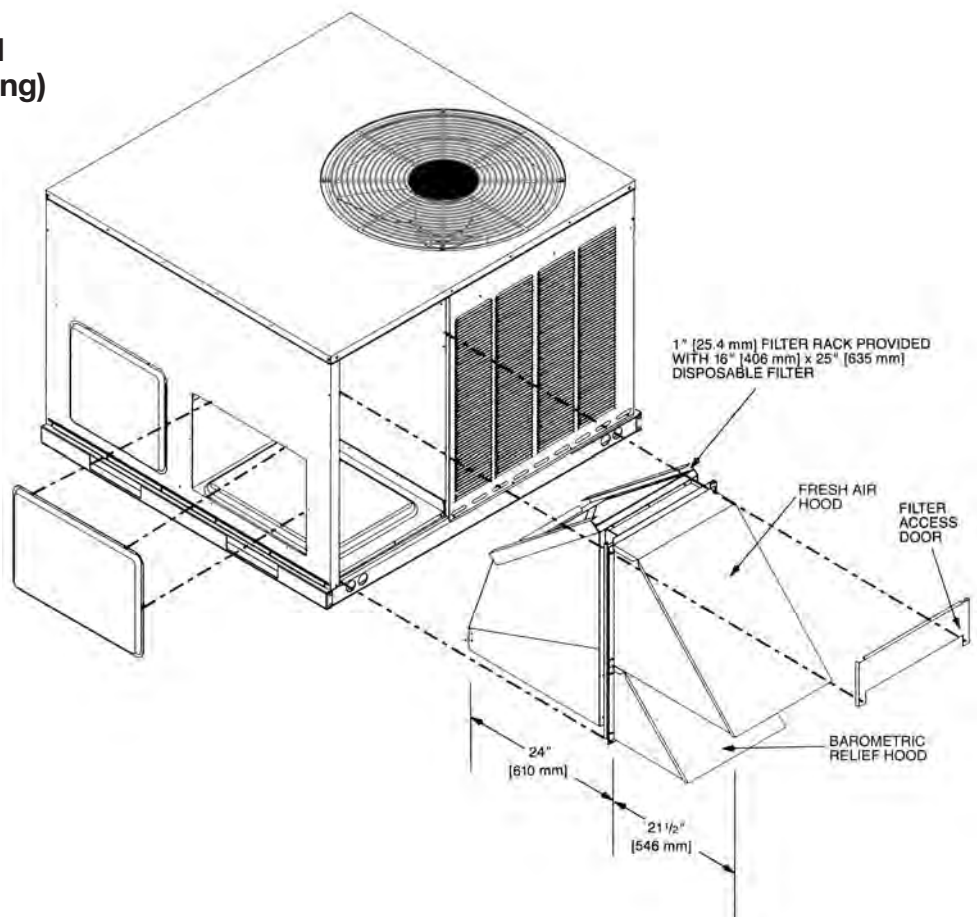

[] Designates Metric Conversions

ECONOMIZERS

RXRD-CCM10 (Fully Modulating) and RXRE-CCA30 (3 Position)

Horizontal Application

AXRD-CCM10 (Fully Modulating)

Provided with enthalpy control, mixed air sensor and minimum position potentiometer for proportioning (modulating) the amount of fresh air.

AXRE-CCA30 (3-Position)

Has outdoor air sensor, minimum position potentiometer and mixed air sensor to provide three damper positions.

[] Designates Metric Conversions

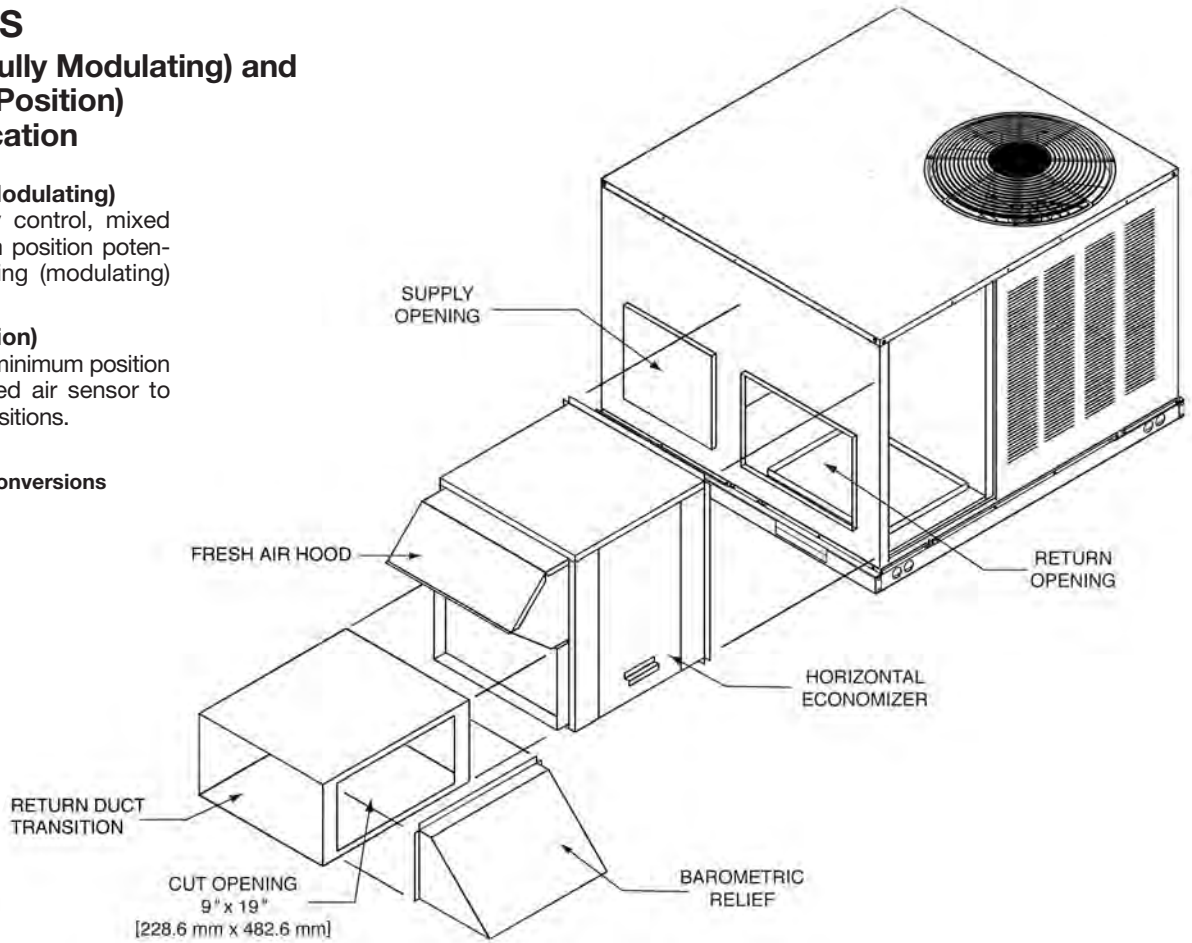

FILTER KIT INSTALLATION

RXRY-B01

For use in either vertical or horizontal discharge.

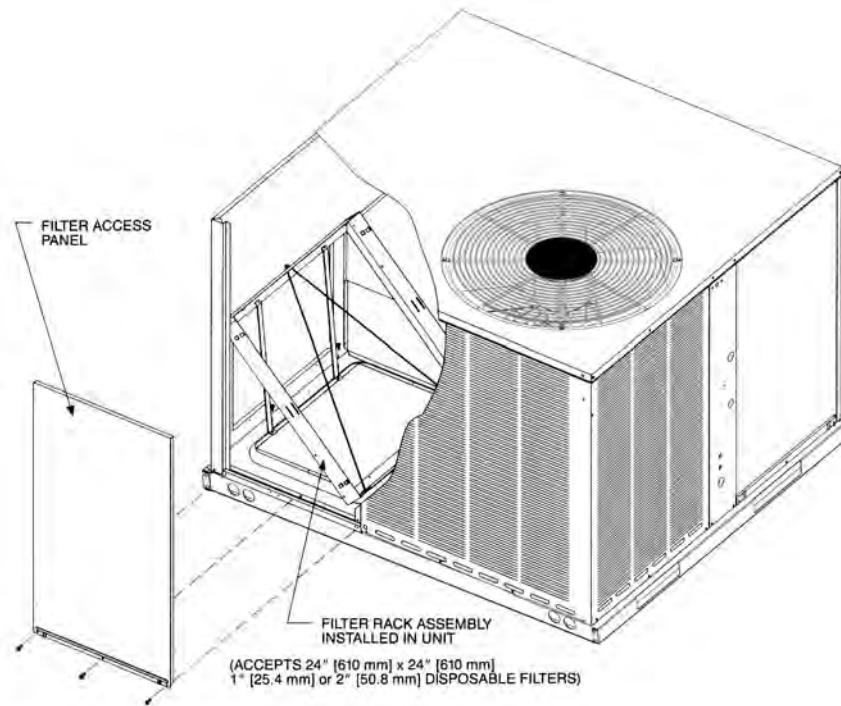

Airflow Pressure Drop, Inches W.C. [kPa]		
CFM [L/s]	1" Filter	2" Filter
500 [236]	.02 [.0050]	.03 [.0075]
600 [283]	.02 [.0050]	.03 [.0075]
700 [330]	.03 [.0075]	.04 [.0101]
800 [378]	.04 [.0101]	.05 [.0124]
900 [425]	.05 [.0124]	.06 [.0149]
1000 [472]	.07 [.0174]	.08 [.0199]
1100 [519]	.08 [.0199]	.09 [.0224]
1200 [566]	.10 [.0249]	.12 [.0299]
1300 [614]	.13 [.0324]	.15 [.0373]
1400 [661]	.16 [.0398]	.19 [.0473]
1500 [708]	.19 [.0473]	.21 [.0523]
1600 [755]	.20 [.0498]	.23 [.0572]
1700 [802]	.21 [.0523]	.24 [.0598]
1800 [850]	.22 [.0548]	.25 [.0623]
1900 [897]	.24 [.0598]	.27 [.0672]
2000 [944]	.26 [.0647]	.29 [.0722]

[] Designates Metric Conversions

DUCT ADAPTER SIDEFLOW SQUARE TO ROUND TRANSITION RXMC-A01

Adapts the side rectangular supply and return openings to 14" [356 mm] diameter round openings. Adapters provided with same finish as unit and also provided with thermal insulation.

[] Designates Metric Conversions

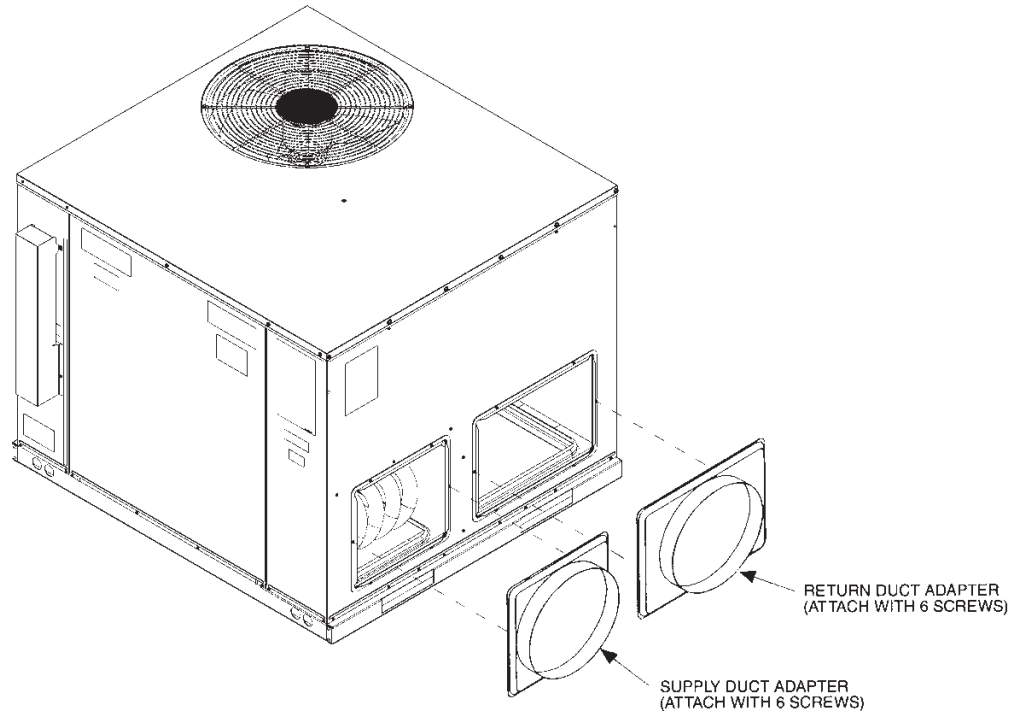

ROOFCURB (Full Perimeter)

RXSG-AAA08, RXSG-AAA14 and RXSG-AAA24

Hinged corners make for fast, easy set-up.

RXSG-AAA08
(8" [203 mm] High)

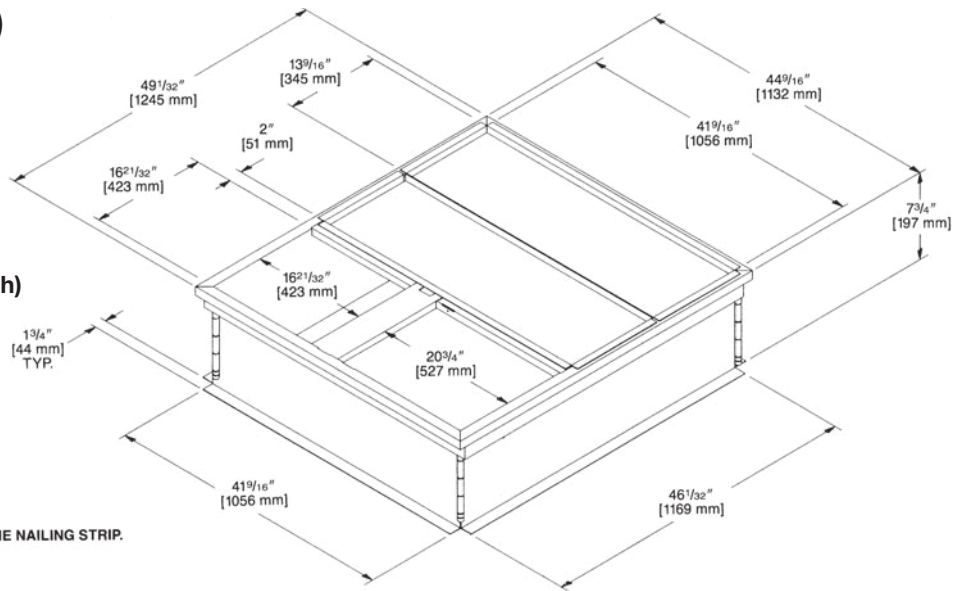

NOTE: PERIMETER OF ROOFCURB IS SUPPLIED WITH A NOMINAL 1" [25.4 mm] x 4" [102 mm] PINE NAILING STRIP.

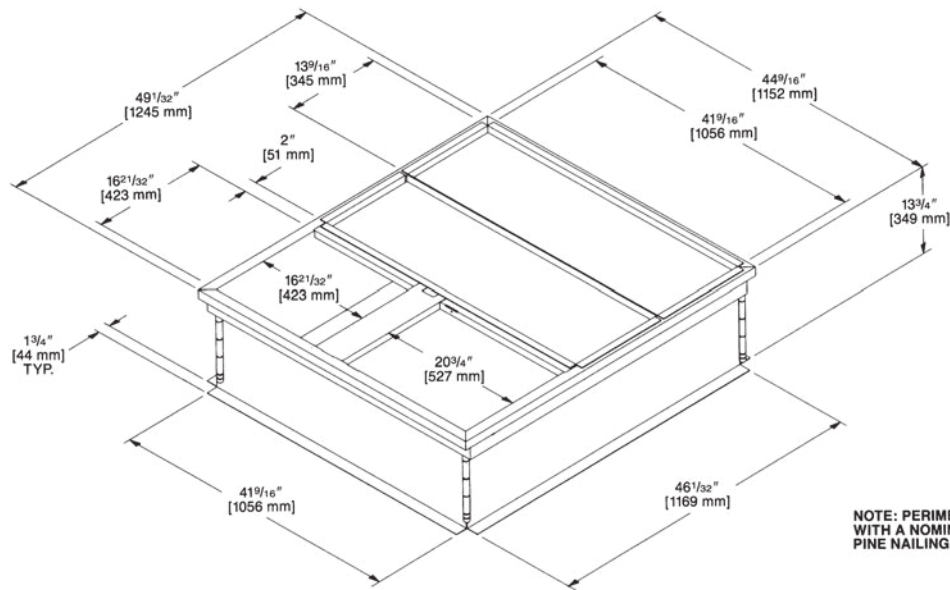

RXSG-AAA14
(14" [356 mm] High)

NOTE: PERIMETER OF ROOFCURB IS SUPPLIED WITH A NOMINAL 1" [25.4 mm] x 4" [102 mm] PINE NAILING STRIP.

RXSG-AAA24
(24" [610 mm] High)

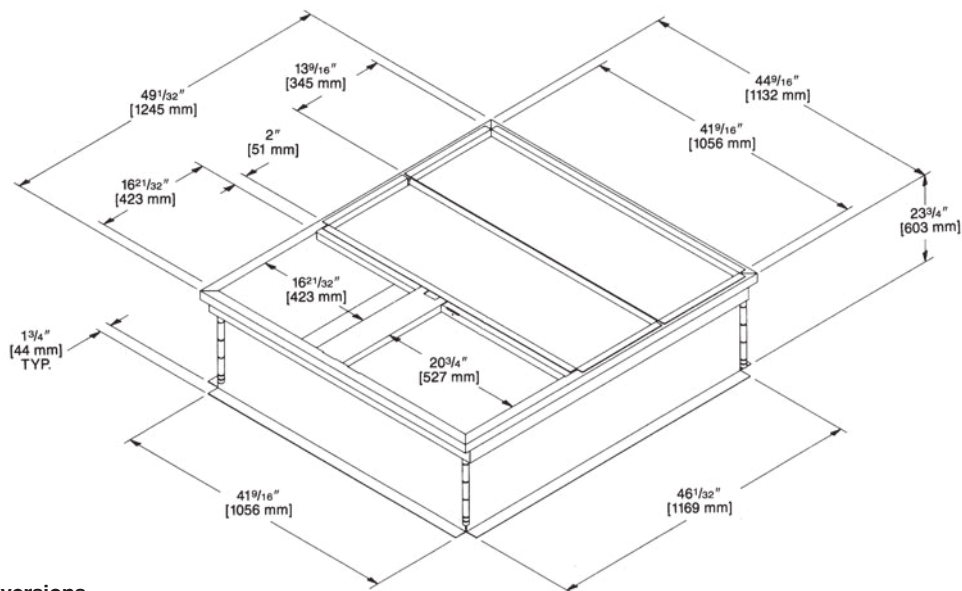

[] Designates Metric Conversions

PACKAGE AIR CONDITIONERS & PACKAGE GAS/ELECTRIC UNITS ROOFCURB INSTALLATION (Full Perimeter)

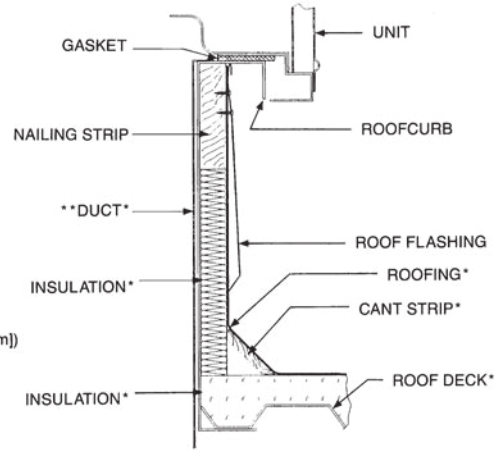
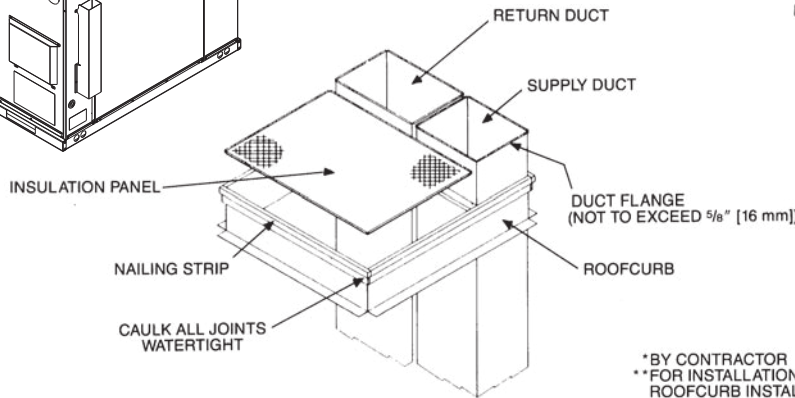
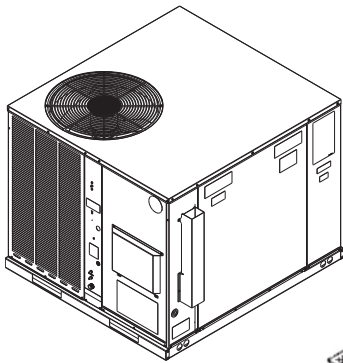

*BY CONTRACTOR
**FOR INSTALLATION OF DUCT AS SHOWN, USE RECOMMENDED DUCT SIZES FROM ROOFCURB INSTALLATION INSTRUCTIONS. FOR DUCT FLANGE ATTACHMENT TO UNIT, SEE UNIT INSTALLATION INSTRUCTIONS FOR RECOMMENDED DUCT SIZES.

ROOFCURB ADAPTERS

Fabricated from galvanized steel to adapt the New cabinet to the old style curb. All are furnished with a New gasket.

OLD MODEL

SMALL CABINET
(1 1/2-2 TON) [5.28-7.03 kW]
RSNC-, RSND-, RSNE-
RRGE-, RRGF-, RRGG-, RSNY

MEDIUM CABINET
(2 1/2-3 TON) [8.79-10.55 kW]
RSNC-, RSND-, RSNE-
RRGE-, RRGF-, RRGG-, RSNY

LARGE CABINET
(3-3 1/2 TON) [10.55-12.31 kW]
RRGE-, RRGF-, RRGG-, RSNY

EXTRA LARGE CABINET
(3 1/2-5 TON) [12.31-17.6 kW]
RSNC-, RSND-, RSNE-
RRGE-, RRGF-, RRGG-, RSNY
(4-5 TON) [14.07-17.58 kW]

OLD CURB MODEL



RXPA-CA20 (1)
RXRA-DB20 (2)

RXPA-CA21 (1)
RXRA-DB21 (2)

RXPA-CA22 (1)
RXRA-DB22 (2)

RXPA-CA23 (1)
RXRA-DB23 (2)

NEW MODEL TO OLD MODEL ROOFCURB ADAPTER



NEW MODEL PACKAGE

ONLY 1 CABINET SIZE—
ALL MODELS



(1) SLOPE TYPE
(2) FULL PERIMETER TYPE

[] Designates Metric Conversions

BEFORE PURCHASING THIS APPLIANCE, READ IMPORTANT ENERGY COST AND EFFICIENCY INFORMATION AVAILABLE FROM YOUR RETAILER.

GENERAL TERMS OF LIMITED WARRANTY*

Rheem will furnish a replacement for any part of this product which fails in normal use and service within the applicable periods stated, in accordance with the terms of the limited warranty.

Heat Exchanger
 Factory StandardTen (10) Years
 Stainless Steel/1-Phase & 3-Phase Models
 Commercial ApplicationTwenty (20) Years
 Stainless Steel/1-Phase Models
 Residential ApplicationLimited Lifetime

Conditional Parts (Registration Required)
 1 Phase, Residential ApplicationsTen (10) Years
Compressor
 1 Phase, Residential ApplicationsTen (10) Years
 1 & 3 Phase, Commercial ApplicationsFive (5) Years
Parts
 Commercial ApplicationsOne (1) Year

***For complete details of the Limited and Conditional Warranties, including applicable terms and conditions, contact your local contractor or the Manufacturer for a copy of the product warranty certificate.**



The new degree of comfort.™

In keeping with its policy of continuous progress and product improvement, Rheem reserves the right to make changes without notice.

Rheem Heating, Cooling & Water Heating • 5600 Old Greenwood Road
Fort Smith, Arkansas 72908 • www.rheem.com

Rheem Canada Ltd./Ltée • 125 Edgeware Road, Unit 1
Brampton, Ontario • L6Y 0P5



INTEGRATED HOME COMFORT

PRINTED IN U.S.A. 7/19 QG FORM NO. R11-870 REV. 5