



www.Source1Parts.com

# TP9C SERIES 97% (ECM) MODULATING MULTI-POSITION 33" NATURAL GAS FURNACES 2ND GENERATION (STYLE B)

HVAC SERVICE PARTS

Supersedes: 035-23646-001 Rev. C (0515)

035-23646-001 Rev. D (1015)

1 of 4

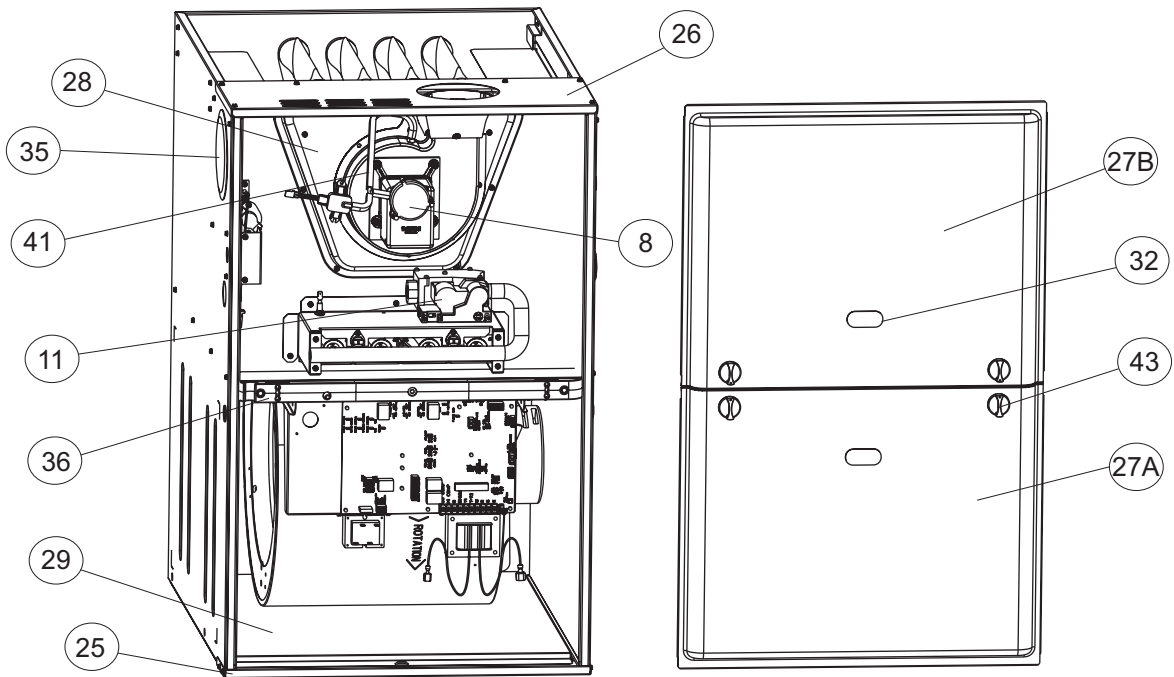

Figure 1: 97% MODULATING (ECM) MULTI-POSITION NATURAL GAS FURNACES<

FIG	ITEM	DESCRIPTION	TP9C060B12MP12CB	TP9C080B12MP12CB	TP9C080C16MP12CB
			(3 BURNER)	(4 BURNER)	(4 BURNER)
<b>MOTOR</b>					
2	1	MOTOR, ECM BLOWER (Programmed)	S1-32436073426	S1-32436073426	S1-32436074427
*	1A	MODULE, CONTROL (Programmed)	S1-32436079426	S1-32436079426	S1-32436080427
*	1B	MOTOR, ECM (Less Module)	S1-02436079000	S1-02436079000	S1-02436080000
*	1C	MOTOR ONLY, NO MODULE	S1-02436073000	S1-02436073000	S1-02436074000
1,2	2	BLOWER, COMBUSTION	S1-32647781000	S1-32647781000	S1-32647781000
<b>ELECTRICAL</b>					
*	3	CHOKE KIT, ECM	---	---	S1-02435605000
3	4	SWITCH, LIMIT(250 Deg Man Reset) (2 ea.)	S1-02541318000	S1-02541318000	S1-02541318000
1,2	5	CONTROL, FURNACE	S1-33102984000	S1-33102984000	S1-33102984000
3	6	IGNITER	S1-02545231000	S1-02545231000	S1-02545231000
3	7	SENSOR, FLAME	S1-02537499000	S1-02537499000	S1-02537499000
1,2	8	SWITCH, PRESSURE	S1-02435979000	S1-02435979000	S1-02435979000
1,2	9	SWITCH, DOOR	S1-02435738000	S1-02435738000	S1-02435738000
1,2	10	TRANSFORMER	S1-2940A3541	S1-2940A3541	S1-2940A3541
1,3	11	VALVE, GAS	S1-02543257000	S1-02543257000	S1-02543257000
2	12	CONTROL, TEMPERATURE	S1-02541336000	S1-02541321000	S1-02541321000
1,2	13	SWITCH, PRESSURE	S1-02435978000	S1-02435978000	S1-02435978000
2	14A	SENSOR, PRESSURE	S1-02435922000	S1-02435922000	S1-02435922000
2	14B	SENSOR, THERMISTOR	S1-03109199000	S1-03109199000	S1-03109199000
<b>AIR MOVING</b>					
1,2	15	HOUSING, BLOWER	S1-37327824001	S1-37327824001	S1-37327824002
2	16	WHEEL, BLOWER	S1-02619654709	S1-02619654709	S1-02619654014
<b>FABRICATED PARTS</b>					
	17				
3	18	BURNER, MAIN GAS	S1-02920482000	S1-02920482000	S1-02920482000
	19				
2	20	SHELF, BLOWER	S1-07327823002	S1-07327823002	S1-07327823003

NOTE: \*Not Shown  
 New replacement parts shown in **bold** face type at the first printing of parts list dated 10/15.  
 Major components and suggested stocking items are shown with shaded item number.  
 "<" Across from row indicates a change in that row, changed part numbers in red.  
 --- Not applicable to specified model.

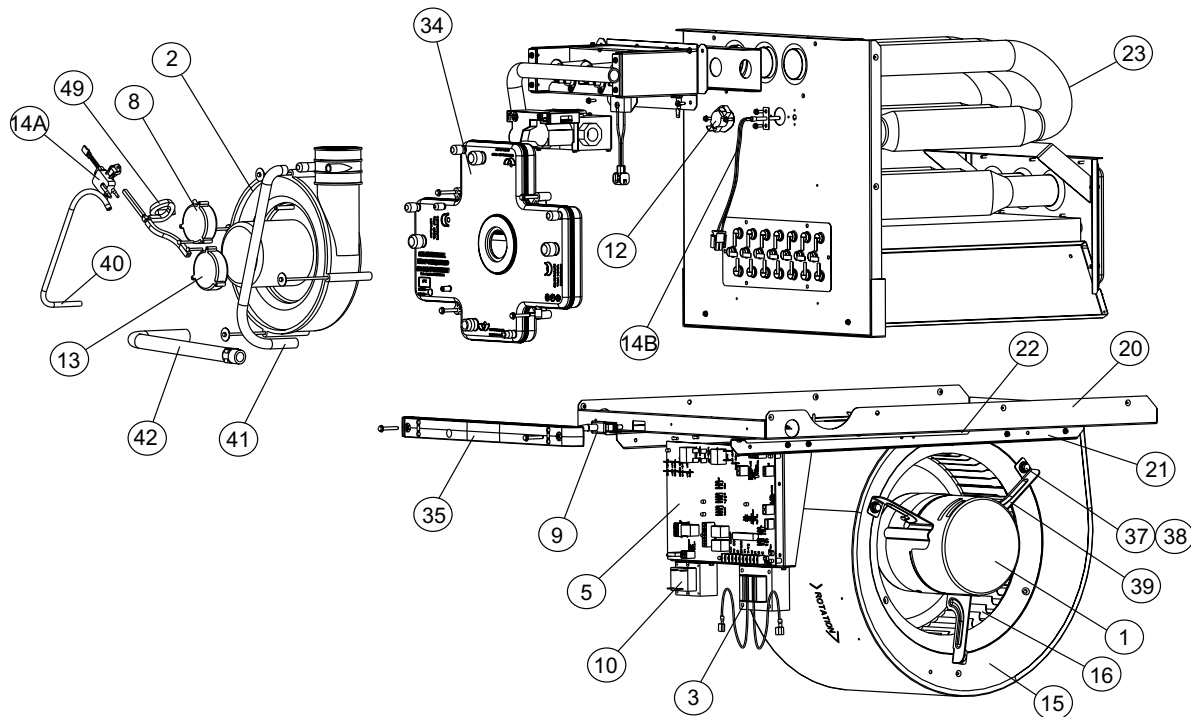

Figure 2: 97% MODULATING (ECM) MULTI-POSITION NATURAL GAS FURNACES

FIG	ITEM	DESCRIPTION	TP9C060B12MP12CB	TP9C080B12MP12CB	TP9C080C16MP12CB
			(3 BURNER)	(4 BURNER)	(4 BURNER)
<b>FABRICATED PARTS (Continued)</b>					
2	21	RAIL, BLOWER (2 Req'd)	S1-07327825001	S1-07327825001	S1-07327825001
2	22	BRACKET, BLOWER TRACK (2 Req'd)	S1-07327825002	S1-07327825002	S1-07327825002
1,2	23	HEAT EXCHANGER ASS'Y	S1-37327871001	S1-37327871002	S1-37327871003
3	24	MANIFOLD, GAS	S1-02924467000	S1-02924468000	S1-02924468000
1	25	PAN, BOTTOM	S1-07327841002	S1-07327841002	S1-07327841003
1	26	PANEL, TOP	S1-07327842002	S1-07327842003	S1-07327842004
1	27A	PANEL, DOOR (Lower)	S1-37327822002	S1-37327822002	S1-37327822003
1	27B	PANEL, DOOR (Upper)	<b>S1-37339423002</b>	<b>S1-37339423002</b>	<b>S1-37339423003</b>
1	28	PANEL, BLOCKOFF	S1-07327827002	S1-07327827002	S1-07327827003
	29				
	30				
<b>MISCELLANEOUS</b>					
3	31	ORIFICE, BURNER (Natural #45)	S1-02921182045	S1-02921182045	S1-02921182045
1	32	SIGHT GLASS, OVAL (2 Req'd)	S1-02538899000	S1-02538899000	S1-02538899000
*	33	GASKET, FOAM (Door) (per ft.)	S1-02815517000	S1-02815517000	S1-02815517000
1,2	34	PAN, CONDENSATE	S1-32816418000	S1-32816419000	S1-32816419000
1,2	35	BRACKET, DOOR	S1-02815513000	S1-02815513000	S1-02815514000
*	36	HARNESS, MAIN WIRING	S1-02543258000	S1-02543258000	S1-02543258000
2	37	FERRULE (3 Req'd)	S1-02320541000	S1-02320541000	S1-02320541000
2	38	GROMMET (3 Req'd)	S1-02814740000	S1-02814740000	S1-02814740000
2	39	MOUNT, MOTOR (Includes item 37 & 38)	S1-37319831002	S1-37319831002	S1-37319831002
2	40	TUBING, EPDM	S1-02816427000	S1-02816427000	S1-02816427000
2	41	HOSE, RAIN GUTTER	S1-02815539000	S1-02815539000	S1-02815539000
2	42	HOSE, CONDENSATE	S1-02815855000	S1-02815540000	S1-02815855000
1	43	PLUG, SEAL, 7/8"	S1-02815853000	S1-02815853000	S1-02815853000
1	44	PLUG, SEAL, 2-3/8"	S1-02815854000	S1-02815854000	S1-02815854000
1	45	PLUG, VENT PIPE	S1-02924406000	S1-02924406000	S1-02924406000
*	46	BAG, PARTS	S1-02924480000	S1-02924480000	S1-02924481000
1	47	KNOB, QUARTER TURN (4 Req'd)	S1-02924485000	S1-02924485000	S1-02924485000
*	48	PLUG, ID	S1-02541370000	S1-02541371000	S1-02541372000
2	49	ASSEMBLY, DRAIN HOSE	S1-02815874000	S1-02815874000	S1-02815874000
*	50	HARNESS, ECM CONTROL (16 Pin)	S1-02541349000	S1-02541349000	S1-02541349000
*	51	HARNESS, ECM MOTOR (5 Pin)	S1-02541460000	S1-02541460000	S1-02541460000
*	52	DIAGRAM, WIRING	531515	531515	531515

NOTE: \*Not Shown  
 New replacement parts shown in **bold** face type at the first printing of parts list dated 1015.  
 Major components and suggested stocking items are shown with shaded item number.  
 "<" Across from row indicates a change in that row, changed part numbers in red.  
 --- Not applicable to specified model.

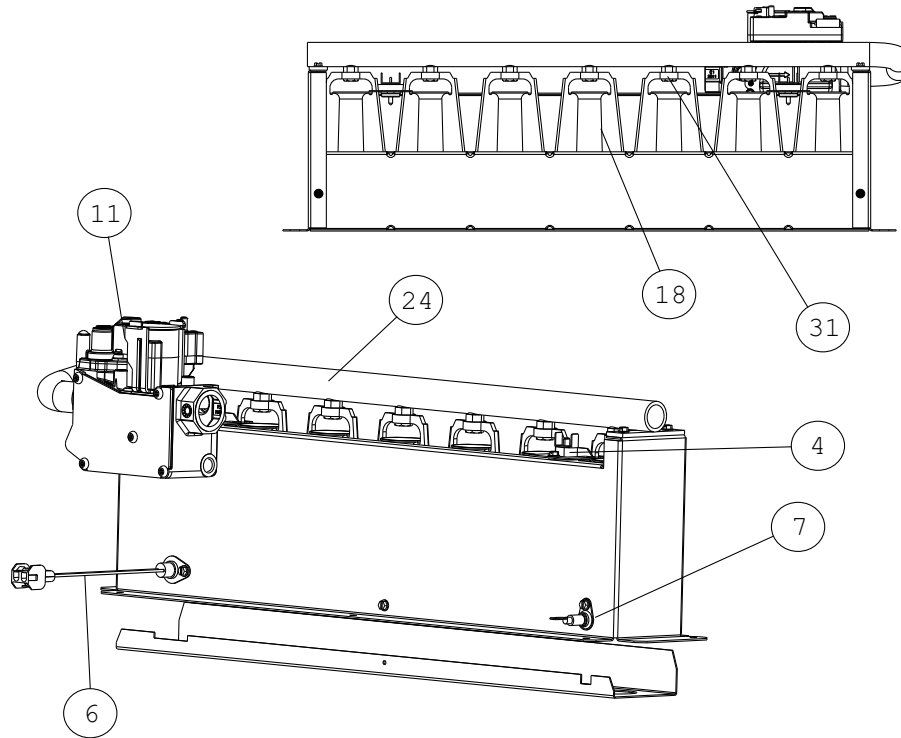

Figure 3: GAS CONTROLS

FIG	ITEM	DESCRIPTION	TP9C100C16MP12CB	TP9C100C20MP12CB	TP9C120D20MP12CB
			(5 BURNER)	(5 BURNER)	(6 BURNER)
<b>MOTOR</b>					
2	1	MOTOR, ECM BLOWER (Programmed)	S1-32436074427	S1-32436074428	S1-32436074428
*	1A	MODULE, CONTROL (Programmed)	S1-32436080427	S1-32436081428	S1-32436081428
*	1B	MOTOR, ECM (Less Module)	S1-02436080000	S1-02436081000	S1-02436081000
*	1C	MOTOR ONLY, NO MODULE	S1-02436074000	S1-02436074000	S1-02436074000
1,2	2	BLOWER, COMBUSTION	S1-32647781000	S1-32647781000	S1-32647781000
<b>ELECTRICAL</b>					
*	3	CHOKE KIT, ECM	S1-02435605000	S1-02435604000	S1-02435604000
3	4	SWITCH, LIMIT (250 Deg, Man Reset) (2 ea.)	S1-02541318000	S1-02541318000	S1-02541318000
1,2	5	CONTROL, FURNACE	S1-33102984000	S1-33102984000	S1-33102984000
3	6	IGNITER	S1-02545231000	S1-02545231000	S1-02545231000
3	7	SENSOR, FLAME	S1-02537499000	S1-02537499000	S1-02537499000
1,2	8	SWITCH, PRESSURE	S1-02435979000	S1-02435979000	S1-02435979000
1,2	9	SWITCH, DOOR	S1-02435738000	S1-02435738000	S1-02435738000
1,2	10	TRANSFORMER	S1-2940A3541	S1-2940A3541	S1-2940A3541
1,3	11	VALVE, GAS	S1-02543257000	S1-02543257000	S1-02543257000
2	12	CONTROL, TEMPERATURE	S1-02541321000	S1-02541321000	S1-02541322000
1,2	13	SWITCH, PRESSURE	S1-02435978000	S1-02435978000	S1-02435978000
2	14A	SENSOR, PRESSURE	S1-02435922000	S1-02435922000	S1-02435922000
2	14B	SENSOR, THERMISTOR	S1-03109199000	S1-03109199000	S1-03109199000
<b>AIR MOVING</b>					
1,2	15	HOUSING, BLOWER	S1-37327824002	S1-37327824002	S1-37327824003
2	16	WHEEL, BLOWER	S1-02619654014	S1-02619654014	S1-02638510000

NOTE: \*Not Shown  
 New replacement parts shown in **bold** face type at the first printing of parts list dated 10/15.  
 Major components and suggested stocking items are shown with shaded item number.  
 "<" Across from row indicates a change in that row., changed part numbers in red.  
 --- Not applicable to specified model.



FIG	ITEM	DESCRIPTION	TP9C100C16MP12CB	TP9C100C20MP12CB	TP9C120D20MP12CB
			(5 BURNER)	(5 BURNER)	(6 BURNER)
<b>FABRICATED PARTS</b>					
	17				
3	18	BURNER, MAIN GAS	S1-02920482000	S1-02920482000	S1-02920482000
	19				
2	20	SHELF, BLOWER	S1-07327823003	S1-07327823004	S1-07327823005
2	21	RAIL, BLOWER (2 Req'd)	S1-07327825001	S1-07327825001	S1-07327825001
2	22	BRACKET, BLOWER TRACK (2 Req'd)	S1-07327825002	S1-07327825002	S1-07327825002
1,2	23	HEAT EXCHANGER ASS'Y	S1-37327871004	S1-37327871004	S1-37327871005
3	24	MANIFOLD, GAS	S1-02924469000	S1-02924469000	S1-02924470000
1	25	PAN, BOTTOM	S1-07327841003	S1-07327841003	S1-07327841004
1	26	PANEL, TOP	S1-07327842005	S1-07327842005	S1-07327842006
1	27A	PANEL, DOOR (Lower)	S1-37327822003	S1-37327822003	S1-37327822004
1	27B	PANEL, DOOR (Upper)	<b>S1-37339423003</b>	<b>S1-37339423003</b>	<b>S1-37339423004</b>
1	28	PANEL, BLOCKOFF	S1-07327827003	S1-07327827003	S1-07327827004
	29				
	30				
<b>MISCELLANEOUS</b>					
3	31	ORIFICE, BURNER (Natural #45)	S1-02921182045	S1-02921182045	S1-02921182045
1	32	SIGHT GLASS, OVAL (2 Req'd)	S1-02538899000	S1-02538899000	S1-02538899000
*	33	GASKET, FOAM (Door) (per ft.)	S1-02815517000	S1-02815517000	S1-02815517000
1,2	34	PAN, CONDENSATE	S1-32816420000	S1-32816420000	S1-32816422000
1,2	35	BRACKET, DOOR	S1-02815514000	S1-02815514000	S1-02815515000
*	36	HARNESS, MAIN WIRING	S1-02543258000	S1-02543258000	S1-02543258000
2	37	FERRULE (3 Req'd)	S1-02320541000	S1-02320541000	S1-02320541000
2	38	GROMMET (3 Req'd)	S1-02814740000	S1-02814740000	S1-02814740000
2	39	MOUNT, MOTOR (Includes item 37 & 38)	S1-37319831002	S1-37319831002	S1-37319831002
2	40	TUBING, EPDM	S1-02816427000	S1-02816427000	S1-02816427000
2	41	HOSE, RAIN GUTTER	S1-02815539000	S1-02815539000	S1-02815539000
2	42	HOSE, CONDENSATE	S1-02815856000	S1-02815856000	S1-02815857000
1	43	PLUG, SEAL, 7/8"	S1-02815853000	S1-02815853000	S1-02815853000
1	44	PLUG, SEAL, 2-3/8"	S1-02815854000	S1-02815854000	S1-02815854000
1	45	PLUG, VENT PIPE	S1-02924406000	S1-02924406000	S1-02924406000
*	46	BAG, PARTS	S1-02924481000	S1-02924481000	S1-02924481000
1	47	KNOB, QUARTER TURN (4 Req'd)	S1-02924485000	S1-02924485000	S1-02924485000
*	48	PLUG, ID	S1-02541373000	S1-02541374000	S1-02541375000
2	49	ASSEMBLY, DRAIN HOSE	S1-02815874000	S1-02815874000	S1-02815874000
*	50	HARNESS, ECM CONTROL (16 Pin)	S1-02541349000	S1-02541349000	S1-02541349000
*	51	HARNESS, ECM MOTOR (5 Pin)	S1-02541460000	S1-02541460000	S1-02541460000
*	52	DIAGRAM, WIRING	531515	531515	531515

NOTE: \*Not Shown  
 New replacement parts shown in **bold** face type at the first printing of parts list dated 10/15.  
 Major components and suggested stocking items are shown with shaded item number.   
 "<" Across from row indicates a change in that row., changed part numbers in red.  
 --- Not applicable to specified model.

**TO ORDER AUTHORIZED FACTORY REPLACEMENT PARTS** - Contact your Source1 HVAC Parts Distributor or visit our website at [www.Source1Parts.com](http://www.Source1Parts.com) for a Distributor and Dealer listing.