

## VBN2, VBN3 Control Ball Valves With Threaded Connections

### PRODUCT DATA

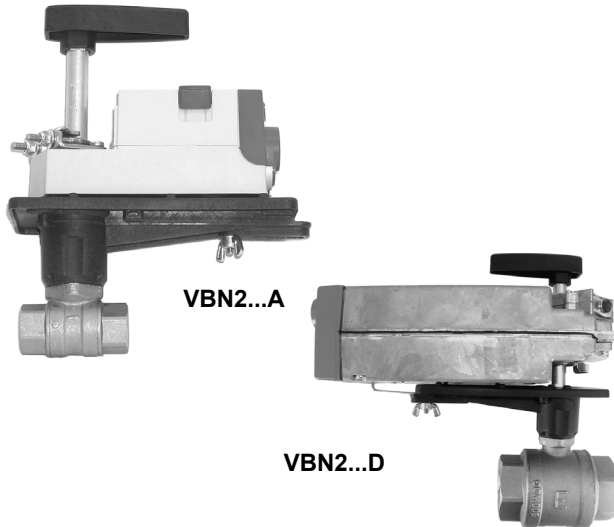

### FEATURES

#### All Models

- Sizes from 1/2 to 2-1/2 inches with internal (female) NPT connections.
- Straight-through flow between A and AB ports.
- Equal percentage or linear flow characteristics.
- Choice of four, factory-installed actuation control schemes: Floating, Modulating (2-10 V), Spring Return 2-Position, Spring Return Modulating/Floating.
- Field configurable for normally open or normally closed fail-safe position.
- Removable manual operating handle to control valve during installation or in an event of power failure.
- ANSI Class IV seat leakage specification (0.01% of  $C_v$ ).
- Optional NEMA 3R (IP54) rated enclosure for outdoor applications.
- Actuator can be mounted on the valve in any of four positions.

#### VBN2 (Two-way)

- Sizes up to 3 inches.
- Wide  $C_v$  choices from 0.38 to 266.
- Nickel-chrome plated brass or 316 stainless steel valve ball and stem.

#### VBN3 (Three-way)

- Wide  $C_v$  choices from 0.33 to 109.
- Valve installs in a globe valve “T” pattern, no extra elbows or piping required.
- Nickel-chrome plated brass valve ball and stem.
- Convertible to straight-through 2-way control by plugging B port (plug not provided.)
- Mixing or Diverting control.

### APPLICATION

The VBN2 Two-Way and the VBN3 Three-Way Control Ball Valves control hot and chilled water with glycol solutions up to 50% in heating, ventilating, and air conditioning (HVAC) systems to provide two-position or modulating functions.

These valve assemblies can be ordered with or without factory-mounted non-spring return or spring return direct-coupled actuators (DCA).

### Contents

Application .....	1
Features .....	1
Specifications .....	2
Ordering Information .....	2
Installation .....	7
Operation and Checkout .....	11
Typical Specifications .....	12



# SPECIFICATIONS

**Models:** See Table 6.

**Dimensions:** See Fig. 1 and 2.

**Body Style:** Two-way ball valve, straight-through flow, full or reduced port using patented flow control insert.  
 Three-way ball valve, A-B-AB flow, full or reduced port using patented flow control insert.  
 Internal NPT connections.

**Body Size:**  
 1/2 to 3 inches NPT (two-way).  
 1/2 to 2-1/2 inches NPT (three-way).

**Flow Capacity:** See Tables 1 and 2.

**Body Pressure Rating (maximum):** 360 psi (2482 kPa) at 250°F (121°C).

**Controlled Medium:** Water or Glycol solutions up to 50%. Not suitable for combustible gases.

**Medium Temperature Range:**  
 -22 to +250°F (-30 to +121°C).

**Maximum Differential Pressure:** See Table 7.

**Flow Characteristics:**  
 Two-way: Equal Percentage with flow control insert.  
 Linear with full port.  
 Three-way: Port A to AB: Equal Percentage.  
 Port B to AB: Linear.

**Materials:**  
 Body: Forged Brass (ASTM B283).  
 Flow Optimizer: Noryl®  
 Ball and Stem:  
 Two-way: Nickel-chrome Plated Brass or 316 Stainless Steel.  
 Three-way: Nickel-chrome Plated Brass.  
 Stem Seals: EPDM O-rings.  
 Ball Seals: Reinforced TEFLON™ Seals with EPDM O-rings.

**Approvals Standards:**  
 Valves: ANSI Class IV close-off/leakage (maximum 0.01% of C<sub>v</sub> let by)  
 Actuators: See literature for the given actuator.

**Parts and Accessories:**  
 5112-11 replacement mounting kit for Honeywell direct coupled actuators. See Fig. 19.

® Registered Trademark of the General Electric Company  
 ™ Registered Trademark of E I DuPont de Nemours

**Table 1. Two-Way C<sub>v</sub> Values.**

	C <sub>v</sub> Designator																		
	B	D	E	F	G	H	J	K	L	M	N	P	R	S	T	U	1	2	
1/2"	0.38	0.68	1.3	2.0	2.6	4.7	8.0	11.7 <sup>a</sup>											
3/4"	0.31	0.63	1.2		2.5	4.3	7.4	10.1	14.7 <sup>a</sup>	29 <sup>a</sup>									
1"						4.4	9.0		15.3	26	44 <sup>a</sup>	54 <sup>a</sup>							
1-1/4"						4.4	8.3	14.9	25	37	41 <sup>a</sup>			102 <sup>a</sup>					
1-1/2"									23	30	41		74					172 <sup>a</sup>	
2"											42	57	71	100	108 <sup>a</sup>			210	266 <sup>a</sup>
2-1/2"											45	55	72	101		162		202 <sup>a</sup>	
3"											49	63	82		124	145 <sup>a</sup>			

<sup>a</sup> Denotes full port valve (with no insert). Provides linear flow control.

# ORDERING INFORMATION

When purchasing replacement and modernization products from your TRADELINE® wholesaler or distributor, refer to the TRADELINE® Catalog or price sheets for complete ordering number.

If you have additional questions, need further information, or would like to comment on our products or services, please write or phone:

1. Your local Honeywell Automation and Control Products Sales Office (check white pages of your phone directory).
2. Honeywell Customer Care  
 1885 Douglas Drive North  
 Minneapolis, Minnesota 55422-4386

In Canada—Honeywell Limited/Honeywell Limitée, 35 Dynamic Drive, Toronto, Ontario M1V 4Z9.

International Sales and Service Offices in all principal cities of the world. Manufacturing in Australia, Canada, Finland, France, Germany, Japan, Mexico, Netherlands, Spain, Taiwan, United Kingdom, U.S.A.

**Table 2. Three-Way C<sub>v</sub> Values.**

	C <sub>v</sub> Designator														
	B	C	D	E	F	G	H	J	K	L	M	N	P	R	S
1/2"	0.33	0.59		1.0	2.4		4.3	8.0							
3/4"		0.40	0.66	1.3	2.4	3.8		7.0	11.0 <sup>a</sup>						
1"		0.40	0.65	1.3	2.3	3.5	4.5	8.6	14.9	22	31				
1-1/4"							4.1	8.7	12.7	19 <sup>a</sup>	27	34 <sup>a</sup>			
1-1/2"							4.0	8.3	13.4	24	32 <sup>a</sup>		61		
2"										24		38	57	83	109
2-1/2"												38		74	100 <sup>a</sup>

<sup>a</sup> Denotes full port valve (with no insert). Provides linear flow control.

**Rangeability**

Rangeability is a measure of a valve's controllability (sometimes referred to as its Turndown Ratio). Rangeability is a measured property and is expressed as the ratio of a valve's maximum flow rate to its minimum controllable flow rate.

**Table 3. Rangeability of two-way actuated ball valves**

Valve Size	C <sub>v</sub>	Rangeability
1/2"	0.38	41
	0.68	17
	1.3	52
	2.0	*
	2.6	321
	4.7	159
	8.0	390
	11.7	251
3/4"	0.31	41
	0.63	17
	1.2	52
	2.5	321
	4.3	159
	7.4	*
	10.1	390
	14.7	251
1"	29	1503
	4.4	159
	9.0	390
	15.3	1040
	26	484
	44	1263
	54	1207

\* Data not available at time of printing

Valve Size	C <sub>v</sub>	Rangeability
1-1/4"	4.4	159
	8.3	390
	14.9	1040
	25	*
	37	484
	41	1207
	102	1263
1-1/2"	23	484
	30	*
	41	603
	74	1263
2"	172	558
	42	603
	57	*
	71	287
	100	*
2-1/2"	108	558
	210	750
	266	877
	45	250
	55	*
3"	72	287
	101	558
	162	750
	202	877
	49	250
	63	287
	82	558
	124	750
	145	877

\* Data not available at time of printing

**Effective C<sub>V</sub>**

When valves are mounted between pipe reducers, there is a decrease in actual valve capacity because the reducers create additional pressure losses in the system. This is especially true for ball valves because of their high capacity.

The C<sub>V</sub> values in Tables 4 and 5 are a guideline. Use the Effective C<sub>V</sub>, not the valve C<sub>V</sub> by itself, to more accurately apply a control valve to the piping system. Multiply the C<sub>V</sub> value by 0.865 to get the capacity in K<sub>VS</sub>, if metric units are required.

**Table 4. Effective C<sub>V</sub>'s Using Pipe Reducers (Two-way)**

Valve Size (in.)	Effective C <sub>V</sub>									
	Pipe Size (NPT)									
	1/2"	3/4"	1"	1-1/4"	1-1/2"	2"	2-1/2"	3"	4"	5"
1/2"	0.38	0.38	0.38	0.38						
	0.68	0.68	0.68	0.68						
	1.3	1.3	1.3	1.3						
	2.0	2.0	2.0	2.0						
	2.6	2.5	2.5	2.4						
	4.7	4.3	4.1	3.9						
	8.0	6.5	5.7	5.4						
3/4"	11.7	7.9	6.7	6.2						
		0.31	0.31	0.31	0.31					
		0.63	0.63	0.63	0.63					
		1.2	1.2	1.2	1.2					
		2.5	2.5	2.5	2.5					
		4.3	4.3	4.2	4.2					
		7.4	7.2	6.4	6.8					
1"		10.1	9.6	9.1	8.8					
		14.7	7.1	6.5	6.2					
		29	21.1	17.1	15.4					
			4.4	4.4	4.4	4.4	4.4	4.3		
			9.0	8.9	8.8	8.7	8.6	8.6		
			15.3	14.9	14.4	13.8	13.5	13.4		
			26	24	22	20	19	19		
1-1/4"			44	37	31	26	24	23		
			54	42	34	28	26	25		
				4.4	4.4	4.4	4.4	4.4	4.4	
				8.3	8.3	8.2	8.2	8.2	8.1	
				14.9	14.8	14.5	14.3	14.2	14.0	
				25	25	23	22	22	22	
				37	35	31	30	29	28	
1-1/2"				41	39	34	32	31	29	
				102	79	53	46	42	39	
					23	22	22	22	22	21
					30	29	28	28	27	27
					41	39	37	36	35	34
					74	64	56	52	48	47
					172	101	77	67	60	57
2"					42	41	41	40	40	
					57	56	54	52	51	
					71	69	65	62	61	
					100	94	87	79	72	
					108	100	92	83	79	
					210	165	135	111	102	
					266	190	146	117	106	
2-1/2"						45	44	43	42	
						55	53	51	50	
						72	67	63	61	
						101	88	80	76	
						162	119	101	94	
						202	132	109	101	
							49	46	45	
3"						63	57	55		
						82	69	67		
						124	90	85		
						145	97	91		

**Table 5. Effective C<sub>V</sub>'s Using Pipe Reducers (Three-way)**

Valve Size (in.)	Effective C <sub>V</sub>									
	Pipe Size (NPT)									
	1/2"	3/4"	1"	1-1/4"	1-1/2"	2"	2-1/2"	3"	4"	5"
1/2"	0.33	0.33	0.30	0.30						
	0.59	0.59	0.60	0.60						
	1.0	1.0	1.0	1.0						
	2.4	2.4	2.3	2.3						
	4.3	4.3	4.0	3.8						
	8.0	8.0	7.9	5.7						
3/4"		0.40	0.40	0.40	0.40					
		0.66	0.66	0.66	0.66					
		1.3	1.3	1.3	1.3					
		2.4	2.4	2.4	2.4					
		3.8	3.8	3.7	3.7					
		12.6	11.7	10.7	10.4					
1"		0.40	0.40	0.40	0.40	0.40	0.40	0.40		
		0.65	0.65	0.65	0.65	0.65	0.65	0.65		
		1.3	1.3	1.3	1.3	1.3	1.3	1.3		
		2.3	2.3	2.3	2.3	2.3	2.3	2.3		
		3.5	3.5	3.5	3.5	3.5	3.5	3.5		
		4.5	4.5	4.5	4.5	4.5	4.4	4.4		
		8.6	8.6	8.5	8.4	8.3	8.2	8.2		
		14.9	14.9	14.6	14.1	13.5	13.3	13.1		
		22	22	21	20	18.0	18.0	17.0		
		31	31	28	25	22	21	21		
1-1/4"				4.1	4.0	4.0	4.0	4.0	4.0	
				7.7	7.7	7.6	7.6	7.6	7.6	
				8.7	8.6	8.6	8.5	8.5	8.5	
				12.7	12.6	12.4	12.3	12.2	12.2	
				19	19	19	18.1	17.9	17.6	
				27	26	25	24	23	23	
				34	33	30	28	27	27	
					4.0	4.0	4.0	4.0	4.0	
1-1/2"					8.3	8.2	8.2	8.2	8.2	
					13.4	13.3	13.2	13.2	13.1	
					24	23	23	22	22	
					32	31	30	29	27	
					61	55	50	47	44	
						24	24	24	24	
						38.	38	37	37	
						57	56	54	52	
2"						83	70	75	70	
						109	101	92	83	
							38	37	37	
							74	68	65	
2-1/2"						100	87	79		

VBN2, VBN3 CONTROL BALL VALVES WITH THREADED CONNECTIONS

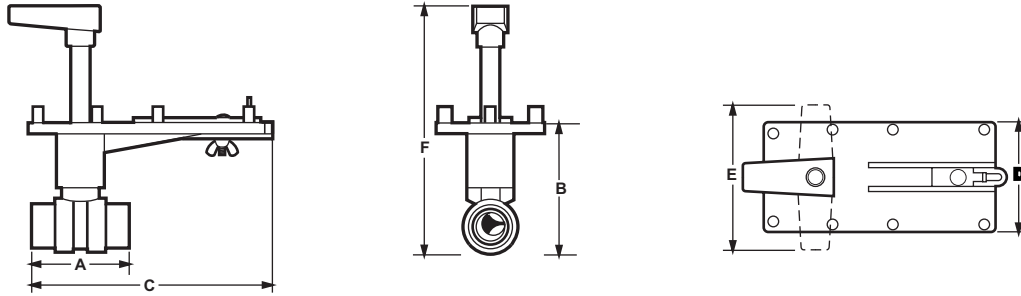

Pipe Size	Model No.	C <sub>v</sub>	Dimensions inches (mm)						Weight lb (kg)
			A	B	C	D	E	F	
1/2"	VBN2A	0.38, 0.68, 1.3, 2.0, 2.6, 4.7, 11.7	2-3/8 (60)	3-7/16 (87)	6-5/8 (168)	3 (76)	4 (102)	8-1/8 (206)	1 (0.5)
		8.0	2-5/8 (67)	3-11/16 (94)	6-1/2 (165)	3 (76)	4 (102)	8-5/16 (211)	1 (0.5)
3/4"	VBN2B	0.31, 0.63, 1.2, 2.5, 4.3, 7.4, 14.7	2-3/8 (60)	3-7/16 (87)	6-7/16 (164)	3 (76)	4 (102)	8-1/8 (206)	1 (0.5)
		10.1, 29	2-5/8 (67)	3-11/16 (94)	6-1/2 (165)	3 (76)	4 (102)	8-5/16 (211)	1 (0.5)
1"	VBN2C	9.0	3-3/4 (95)	3-11/16 (94)	7-1/16 (179)	3 (76)	4 (102)	8-5/16 (211)	1 (0.5)
		4.4, 15.3, 54	3 (76)	3-15/16 (100)	6-3/4 (171)	3 (76)	4 (102)	8-11/16 (221)	1.4 (0.6)
		26, 44	4-3/8 (111)	4-7/16 (113)	7-3/8 (187)	3 (76)	4 (102)	8-7/8 (225)	2.4 (1.1)
1-1/4"	VBN2D	4.4, 8.3, 14.9, 25, 41	3 (76)	3-15/16 (100)	6-11/16 (170)	3 (76)	4 (102)	8-11/16 (221)	1.4 (0.6)
		37, 102	3-5/8 (92)	4-7/16 (113)	7 (178)	3 (76)	4 (102)	9-1/16 (231)	2.4 (1.1)
1-1/2"	VBN2E	23, 30, 74	3-3/8 (86)	3-15/16 (100)	6-15/16 (176)	3 (76)	4 (102)	9-1/16 (231)	2.4 (1.1)
		41, 172	3-3/4 (95)	5-3/16 (132)	7-1/16 (179)	3 (76)	4 (102)	8-7/8 (225)	3.2 (1.5)
2"	VBN2F	42, 108	4 (102)	5-3/16 (132)	7-3/16 (183)	3 (76)	4 (102)	8-7/8 (225)	3.2 (1.5)
		57, 71, 100, 210, 266	4-3/8 (111)	5-3/4 (146)	7-7/16 (189)	3 (76)	4 (102)	10-1/2 (267)	5 (2.3)
2-1/2"	VBN2G	45, 55, 72, 101, 162, 202	4-3/4 (121)	5-3/4 (146)	7-9/16 (192)	3 (76)	4 (102)	10-1/2 (267)	5.5 (2.5)
3"	VBN2H	49, 63, 82, 124, 145	5 (127)	5-7/8 (149)	7-11/16 (195)	3 (76)	4 (102)	10-11/16 (271)	5.9 (2.7)

M23550

Fig. 1. VBN2 dimensions in inches (millimeters).

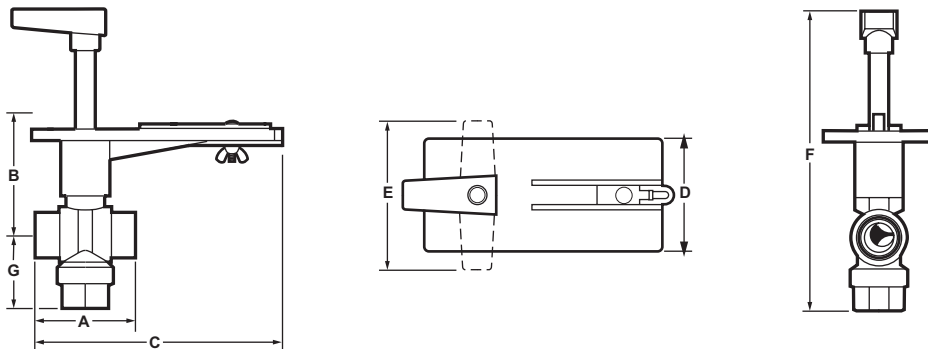

Pipe Size	Model No.	C <sub>v</sub>	Dimensions inches (mm)						Weight lb (kg)	
			A	B	C	D	E	F		G
1/2"	VBN3A	0.33, 0.59, 1.0, 2.4, 4.3, 8.0	3-1/2 (90)	3-5/16 (84)	7 (178)	3 (76)	4 (102)	9-3/8 (238)	2-3/8 (60)	2.4 (1.1)
3/4"	VBN3B	0.40, 0.66, 1.3, 2.4, 3.8, 7.0, 11.0	2-13/16 (71)	3-5/16 (84)	6-1/2 (168)	3 (76)	4 (102)	8-13/16 (224)	2 (51)	2 (0.9)
1"	VBN3C	0.40, 0.65, 1.3, 2.3, 3.5	3-13/16 (97)	3-5/16 (84)	7-5/16 (186)	3 (76)	4 (102)	9-1/2 (241)	2-3/4 (70)	2.8 (1.3)
		8.6, 22	3 (76)	3-13/16	6-13/16 (173)	3 (76)	4 (102)	9-13/16 (249)	2-5/8 (67)	2.6 (1.2)
		4.5, 14.9, 31	4-1/2 (114)	4 (102)	7-13/16 (198)	3 (76)	4 (102)	10-13/16 (275)	3-1/4 (83)	3.3 (1.5)
1-1/4"	VBN3D	4.1, 8.7, 19.0	3 (76)	3-13/16	6-13/16 (173)	3 (76)	4 (102)	9-13/16 (249)	2-1/2 (64)	2.5 (1.1)
		12.7, 27, 34	3-5/8 (92)	4 (102)	7-5/16 (186)	3 (76)	4 (102)	10-5/16 (262)	2-3/4 (70)	2.8 (1.3)
1-1/2"	VBN3E	4.0, 8.3, 13.4, 32	4-1/2 (114)	4 (102)	7-13/16 (198)	3 (76)	4 (102)	10-13/16 (275)	3-1/4 (83)	3.3 (1.5)
		24, 61	4 (102)	4-1/2 (114)	7-5/16 (186)	3 (76)	4 (102)	11 (279)	3-1/4 (83)	3.3 (1.5)
2"	VBN3F	24, 38, 57	4 (102)	4-1/2 (114)	7-5/16 (186)	3 (76)	4 (102)	11 (279)	3-1/4 (83)	3.3 (1.5)
		83, 109	5 (127)	5-13/16	7-13/16 (198)	3 (76)	4 (102)	12-5/16 (313)	3-3/4 (95)	3.8 (1.7)
2-1/2"	VBN3G	38, 74, 100	5 (127)	5-13/16	7-13/16 (198)	3 (76)	4 (102)	12-5/16 (313)	3-3/4 (95)	3.8 (1.7)

M23551

Fig. 2. VBN3 dimensions in inches (millimeters).

Table 6. Model Selection.

Valve	Fitting	Body/Flow Type	Size	C <sub>v</sub>	T/P	Trim	Enclosure	Actuator
VB = valve, ball								
N = Female NPT threaded								
2 = 2 way equal percentage, or linear flow characteristic, as noted in Table 1.								
3 = 3 way mixing equal percentage, or linear flow characteristic, as noted in Table 2.								
				inch	S.I. metric			
A—				1/2	DN15			
B—				3/4	DN20			
C—				1	DN25			
D—				1-1/4	DN32			
E—				1-1/2	DN40			
F—				2	DN50			
G—				2-1/2	DN65			
H—				3	DN80			
				B				
				C				
				D				
				E				
				F				
				....				
				T				
				U				
				1	C <sub>v</sub> Designator			
				2	See Table 1 for Two-way valves.			
					See Table 2 for Three-way valves.			
				3	= ANSI 300 Valve construction			
					P	= Plated (chrome or nickel)		
					S	= Stainless Steel		
					0	= no enclosure		
					R	= NEMA 3R enclosure		
					X	= no actuator		
					A	= NSR, Floating		
					B	= NSR, Modulating		
					C	= SR, 2-Position, 24 Vac		
					D	= SR, Floating/Modulating		
VB	N	2	A	B	3	P	0	A

### Application Notes

**IMPORTANT**

Valve sizing is important for correct system operation. Undersized valves do not have sufficient capacity at maximum load. Oversized valves do not have sufficient authority over the load in modulating applications.

Oversized valves can cause excessive cycling and the seat and ball can be damaged because of the restricted opening.

### Proper Use

These valves are only for use in cold, warm, hot water systems and for steam applications. They are designed for a medium temperature range of from 35 to 250°F, at a maximum pressure of 360 psig VBN valves are to be operated with the appropriate Honeywell direct coupled actuators only.

Water should be properly filtered, treated and conditioned according to local conditions and the recommendations of the boiler or chiller manufacturers. The installation of a strainers and filters is recommended.

**IMPORTANT**

The presence of excessive iron oxide (red rust) in the system voids the valve warranty.

## Flow Characteristics

The VBN2 Two-Way Ball Valves have:

- an equal percentage flow characteristic with characterized flow control insert.
- a linear flow characteristic with full port balls.

The VBN3 Three-Way Ball Valves have:

- between ports A and AB: an equal percentage flow characteristic.
- between ports B and AB: a linear flow characteristic.

## Required Operating Torque

Both Honeywell non-spring return and spring return low torque direct coupled actuators can be utilized with the VBN2 and VBN3 valves. VB valves use a patented seat design that reduces the torque needed from the actuator. A 35 lb-in. DCA provides sufficient torque to close the valve at rated close-off. (See Table 6.) These ratings exceed most HVAC application requirements.

**Table 7. Close-off, Differential Pressure Ratings.**

Valve Type	Valve Size	Close-off Pressure Rating (psi)
2 way	1/2", 3/4"	130
	1", 1-1/4", 1-1/2", 2", 2-1/2", 3"	100
3 way	1/2", 3/4", 1"	50
	1-1/4", 1-1/2", 2", 2-1/2"	40

NOTE: 3-way close-off ratings apply to 3-way valves with the B port plugged

## INSTALLATION

### When Installing this Product...

1. Read these instructions carefully. Failure to follow them could damage the product or cause a hazardous condition.
2. Check ratings given in instructions and on the product to ensure the product is suitable for your application.
3. Installer must be a trained, experienced service technician.
4. After installation is complete, check out product operation as provided in these instructions.

## Preparation



### CAUTION

#### Equipment Damage Hazard

Foreign particles like dirt and metal chips can damage the ball seals.

For trouble-free operation of the product, good installation practice must include initial system flushing, and chemical water treatment. Clean the lines upstream of particles larger than 1/16 inch diameter (welding slag, pipe scale, sand and other suspended particulate). Use of a 50 micron (or finer) system side stream filter is suggested. Remove all filters before flushing.

Do not use boiler additives, solder flux and wetted materials which are petroleum based or contain mineral oil, hydrocarbons, or ethylene glycol acetate. Compounds which can be used, with minimum 50% water dilution, are diethylene glycol, ethylene glycol, and propylene glycol (antifreeze solutions).

If installing these valves in an addition to, or retrofitting an existing building, do not assume that the fluid in the existing piping meets these criteria.

#### IMPORTANT

*Hold valve with pipe wrench by hexagonal fitting ONLY. Do NOT handle the valve body with the pipe wrench; product damage may result.*

1. Clean the lines upstream of particles larger than 1/16 in. diameter (welding slag, pipe scale and other contaminants).
2. Proceed with installation once the system specifics (expansion/contraction of the system and its medium as well as operating pressures) are within tolerances.
3. Eliminate air from system.
4. Two-way valves are marked to show flow direction.

#### IMPORTANT

*Flow arrows must point in the direction of the flow for proper operation.*

NOTE: For three-way valve mounting, see Fig. 3 through 4.

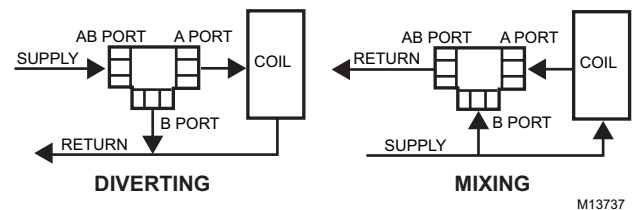

**Fig. 3. Three-way ball valve flow orientation (not to scale).**

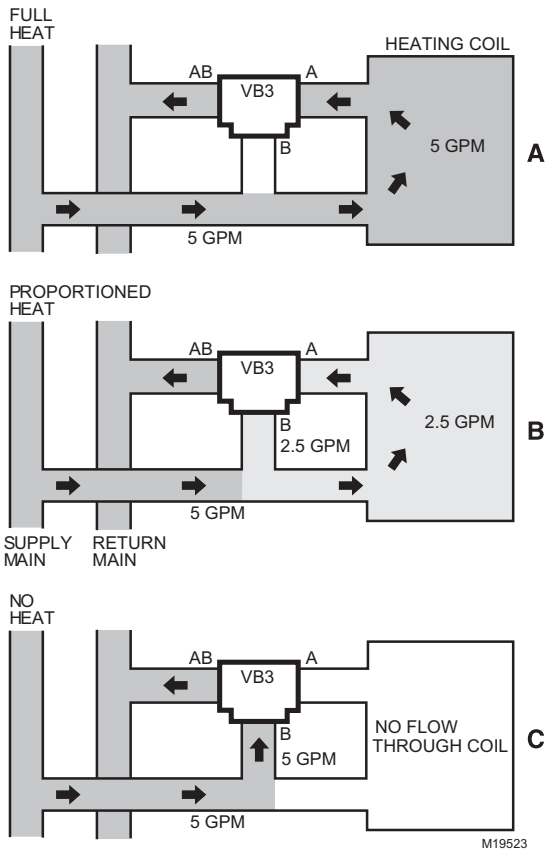

Fig. 4. Three-way mixing valve operation with coil bypass.

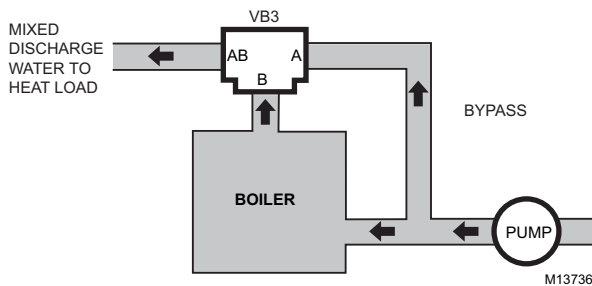

Fig. 5. Boiler bypass for reset control.

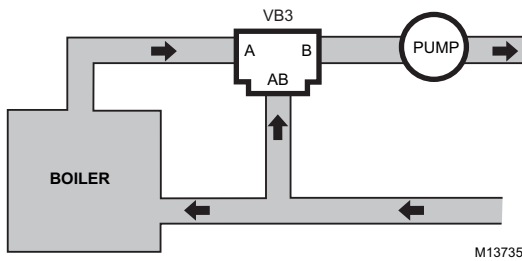

Fig. 6. Supply mixing for reset control.

5. Stem rotation:
  - a. For two-way valves:
    - (1) Clockwise to close.
    - (2) Counterclockwise to open.
  - b. For three-way valves:
    - (1) Clockwise to increase B to AB flow.
    - (2) Counter clockwise to increase A to AB flow.

NOTE: After valves have been installed in the piping, the installer can determine the ball orientation within the valve from the notches in the top of the valve stem. For two-way valves, the lengthwise direction of the notch indicates the flow through the ball (i.e. when the notch is parallel to the axis of the valve between A and B ports, the ball will allow flow through the valve). For three-way valves, the flow can be determined by the orientation of the "T" shaped notch in the valve stem, as shown in Fig. 7.

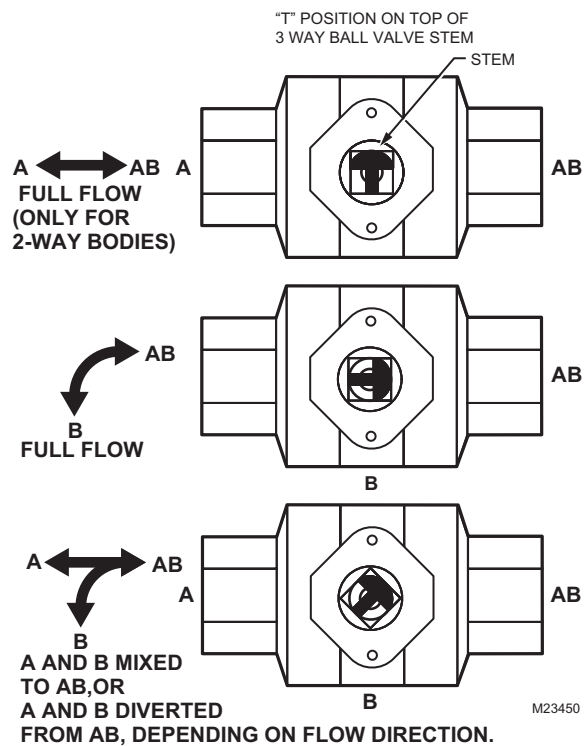

Fig. 7. Orientation of ball in valve

6. Valve must be mounted with the actuator/bracket above the valve body. Do not install the valve with the stem below horizontal or upside down. (See Fig. 7 and 8.)

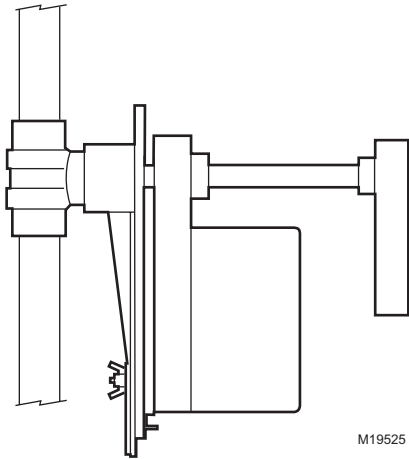

Fig. 8. Vertical valve installation

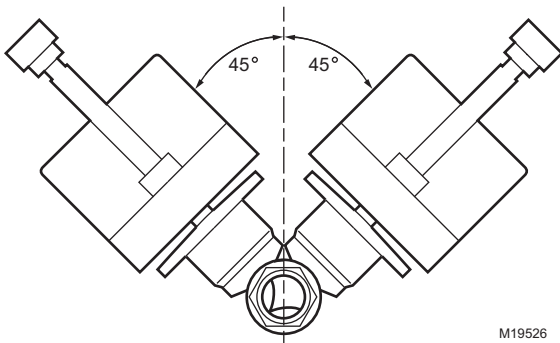

Fig. 9. Acceptable valve angle from vertical

## Mechanical Installation

The valves are tapped in NPT and should be sealed with an approved pipe sealant. Torque should not exceed 75 lb-ft.

See Fig. 1 and 2 for valve dimensions. Refer to actuator literature for actuator dimensions.

## Mounting Plate Adjustment

The Actuator Mounting Plate can be rotated to a different position for installation in confined spaces. This is accomplished as follows:

1. Remove the handle from the shaft and set it aside.
2. Remove the two screws that hold the stem assembly to the mounting plate and set them aside.
3. Remove and set aside the stem assembly.
4. Remove and set aside the two screws that attach the mounting plate to the valve.
5. Remove and set aside hold-down ring from mounting plate.
6. Rotate mounting plate around valve top to the desired position.

NOTE: Take note of the screw hole positions on the valve. They limit the mounting plate positions.

7. Lower ring down to valve body and engage it in the new position relative to the mounting plate.
8. Tighten screws to valve body securing the mounting plate.

9. Reattach the stem assembly to the mounting plate.
10. If desired, replace the handle on the shaft.

NOTE: See Fig. 19 for valve exploded view.

## Electrical Installation

1. If necessary, remove actuator wiring cover.
2. Wire actuator using Figures 10 through 18 for the application required.
3. Replace cover.

## Wiring

### VALVES WITH NON-SPRING RETURN ACTUATORS (MN6105, MN7505)

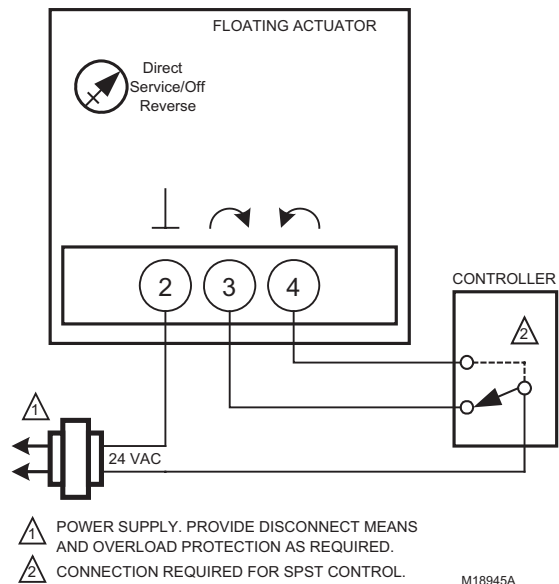

Fig. 10. Wiring for On/Off Control

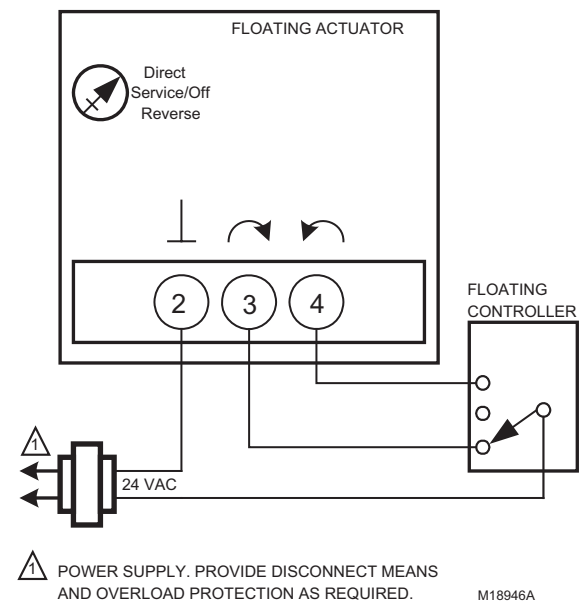

Fig. 11. Wiring for Floating Control

VBN2, VBN3 CONTROL BALL VALVES WITH THREADED CONNECTIONS

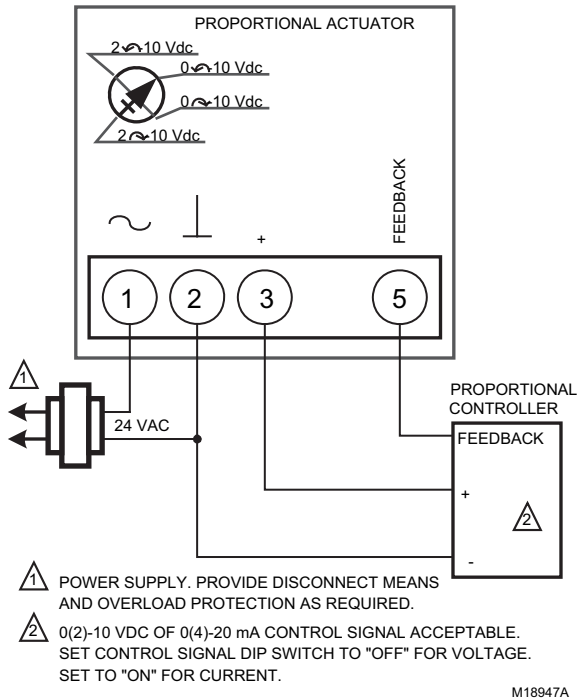

Fig. 12. Wiring for Modulating Control

VALVES WITH SPRING RETURN ACTUATORS (MS7505, MS8105)

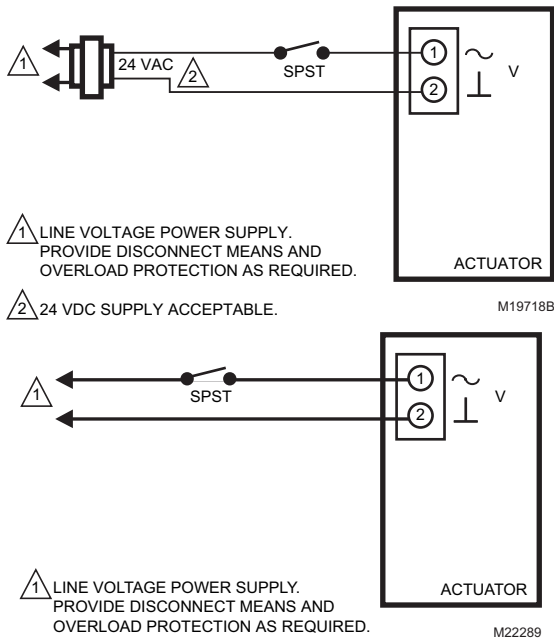

Fig. 13. Wiring for On/Off Control

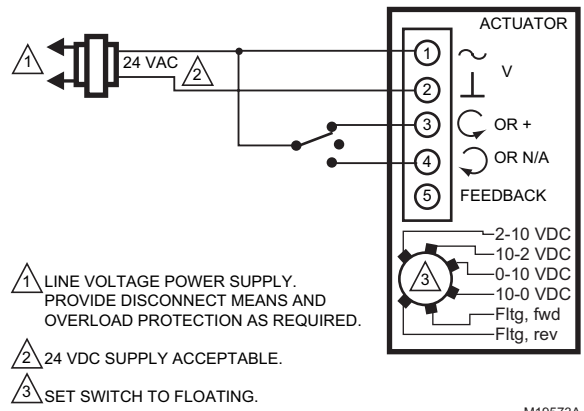

Fig. 14. Wiring for Floating Control (Floating mode setting)

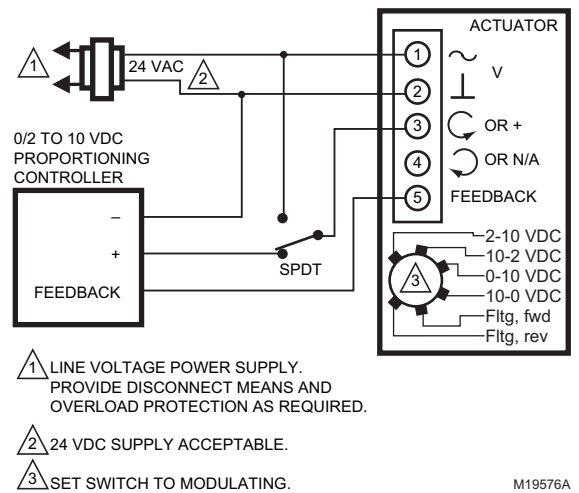

Fig. 15. Override to full open (Modulating mode setting)

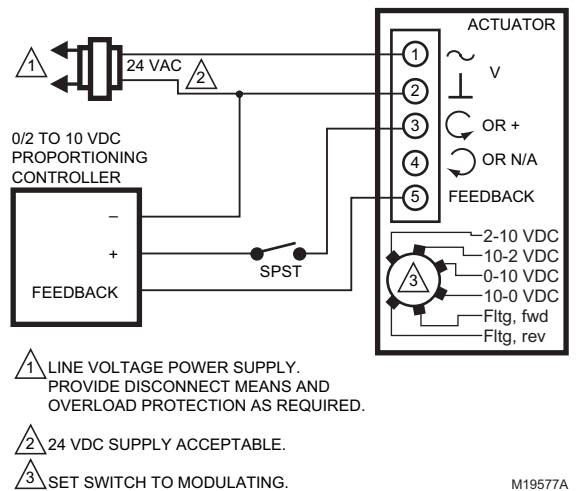
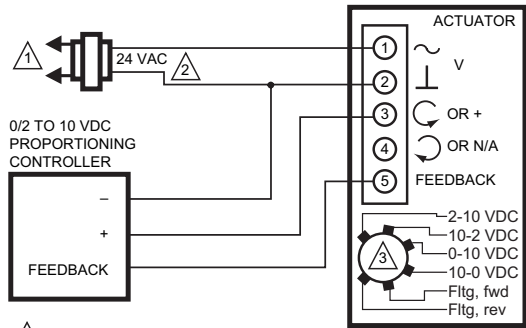

Fig. 16. Override to full closed (Modulating mode setting)



1 LINE VOLTAGE POWER SUPPLY. PROVIDE DISCONNECT MEANS AND OVERLOAD PROTECTION AS REQUIRED.

2 24 VDC SUPPLY ACCEPTABLE.

3 SET SWITCH TO MODULATING.

M19574A

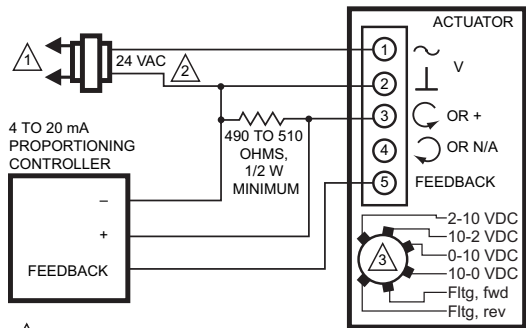

1 LINE VOLTAGE POWER SUPPLY. PROVIDE DISCONNECT MEANS AND OVERLOAD PROTECTION AS REQUIRED.

2 24 VDC SUPPLY ACCEPTABLE.

3 SET SWITCH TO MODULATING.

M22282A

**Fig. 17. Wiring for Proportioning Controllers (Modulating mode setting)**

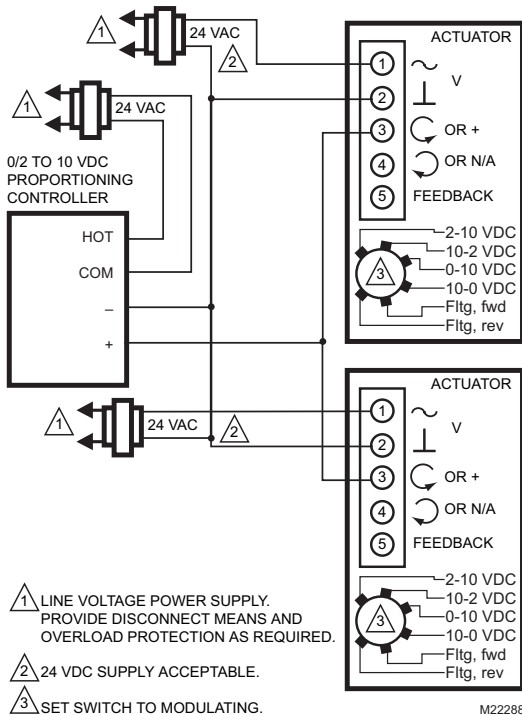

1 LINE VOLTAGE POWER SUPPLY. PROVIDE DISCONNECT MEANS AND OVERLOAD PROTECTION AS REQUIRED.

2 24 VDC SUPPLY ACCEPTABLE.

3 SET SWITCH TO MODULATING.

M22288

**Fig. 18. Wiring for Proportioning controllers operating multiple actuators (Modulating mode setting)**

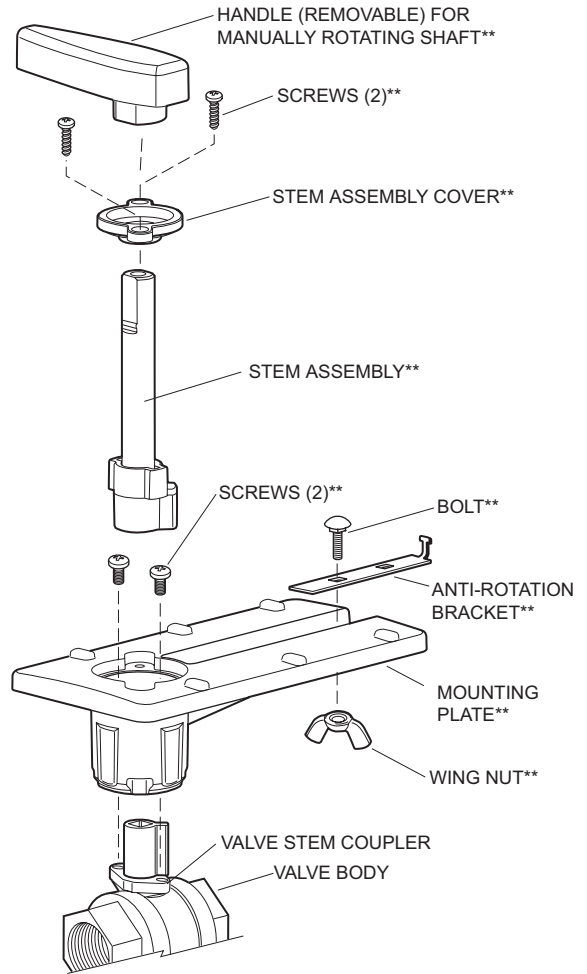

\*\*INCLUDED IN REPLACEMENT KIT (PART NO. 5112-11)

M13738

**Fig. 19. Valve assembly exploded view.**

NOTE: All identified parts except for the valve body and aluminum valve stem coupler are included in Replacement Kit (part no. 5112-11)

## OPERATION AND CHECKOUT

Once both the mechanical and electrical installations are complete:

1. Cycle the actuator to verify that the direction of rotation suits the control sequence.
2. If the rotation direction is incorrect:
  - a. For 2-position control actuators: Remount actuator on the bracket.
  - b. For floating control actuators: Reverse two control signal wires (CW/CCW).
  - c. For analog control actuators either:
    - (1) Reposition reverse/direct acting switch, or
    - (2) Remount actuator on the bracket.
3. If the control scheme requires fail-safe operation, ensure that, upon removal of power, the fail position coincides with the control sequence.

4. If the fail safe position is incorrect, remove and reinstall the actuator in the opposite orientation as follows:
  - a. Loosen the shaft coupling bolt using a 10 mm wrench.
  - b. Loosen all other mounting bolts connecting the actuator to the mounting bracket, and set aside.
  - c. Remove the actuator from the valve shaft.
  - d. Move the actuator coupling to the opposite side of the actuator, as displayed in Figure 20.

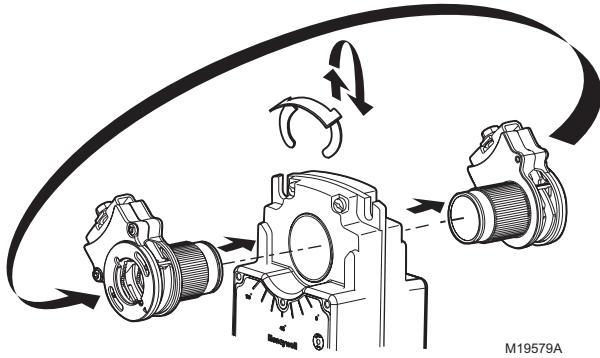

**Fig. 20. Mounting shaft coupling to actuator opposite side.**

- (1) Remove the retainer clip from the shaft coupling and set it aside for later use.
  - (2) Remove shaft coupling from one side of the actuator.
  - (3) Replace the shaft coupling on the opposite side of the actuator, aligning it based on the stroke labelling.
  - (4) Replace the retainer clip on the shaft coupling using the groove of the coupling.
- e. Reconnect the actuator to the valve mounting bracket by replacing the screws previously removed (step b)
  - f. Tighten the shaft coupling bolt using a 10 mm wrench.

For detailed actuator information, see Honeywell literature:

- 63-2607—MS7505/MS8105 Actuator Product Data
- 63-2632—MN6105/MN7505 Floating Actuator Product Data
- 63-2633—MN6105/MN7505 Modulating Actuator Product Data

## TYPICAL SPECIFICATIONS

### Ball Valve

Valve housing shall consist of forged brass rated at no less than 360 psi at 250°F. Standard valve ball shall consist of chemically nickel-plated brass. Manufacturer shall be able to provide optional 316 stainless steel ball and stem for two-way valves. Valve shall have a blow-out proof stem with two EPDM O-rings with minimum 600 psi rating. Manufacturer shall be able to provide glass-filled polymer ball insert to make flow control equal percentage. Valves shall be Honeywell. Two-way valves shall have EPDM O-rings behind ball seals to allow for a minimum close-off pressure of 100 psi with actuator which provides 35 lb-in. torque for 1/2 to 3 inches sizes. Valve shall be available with a minimum of 53 unique  $C_V$  values. Valve shall be available with threaded (FNPT) end connections. Three-way valves shall be installed in a “T” configuration with actuator perpendicular to shaft. Valve shall not require elbows of any kind. Three-way valves shall have EPDM O-rings behind ball seals to allow for a minimum close-off pressure of 40 psi with an actuator that provides 35 lb-in. torque for 1/2 to 2-1/2 inches sizes. Three-way valves must be available in both mixing and diverting configurations and shall be available with a minimum of 42 unique  $C_V$  values. Valve shall be available with threaded (FNPT) end connections.

### Valve Actuator

Control valve actuator shall accept analog modulating [(0)2-10 Vdc], floating (tri-state), or two-position signal as indicated in the control sequence. Actuators shall be by Honeywell. Actuator shall provide minimum torque required for full valve shutoff position. Wiring terminals shall be provided for installation to control signal and power wiring.

Actuator shall be available with housing suitable for outdoor installation.

Accessories Identification tags shall be available for all valves; tags shall be indelibly marked with  $C_V$ , model number, and tag location.

### Automation and Control Solutions

Honeywell International Inc.  
1985 Douglas Drive North  
Golden Valley, MN 55422  
customer.honeywell.com

Honeywell Limited-Honeywell Limitée  
35 Dynamic Drive  
Toronto, Ontario M1V 4Z9

