

B351L Steel C-Clamp with Locknut

- Safety Factor of 5
- Setscrew and locknut included
- When Retaining Strap is required, order B3362, B3363 or B3365 separately
- Standard finishes: ZN, SS4, PLN

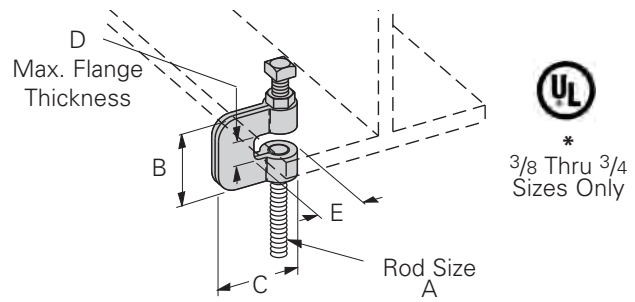

Part Number With Locknut	Rod Size A	B		C		D		E		Design Load		Wt./C	
		In.	mm	In.	mm	In.	mm	In.	mm	Lbs.	kN	Lbs.	kg
B351L-3/8 *	3/8"-16	2 3/8"	(60.3)	2 3/8"	(60.3)	3/4"	(19.0)	1 3/8"	(34.9)	230	(1.03)	41	(18.6)
B351L-1/2 *	1/2"-13	2 3/8"	(60.3)	2 3/8"	(60.3)	3/4"	(19.0)	1 3/8"	(34.9)	380	(1.71)	41	(18.6)
B351L-5/8 *	5/8"-11	2 3/8"	(60.3)	2 1/4"	(57.1)	3/4"	(19.0)	1 3/8"	(34.9)	550	(2.47)	60	(27.2)
B351L-3/4 *	3/4"-10	2 3/8"	(60.3)	3 1/4"	(82.5)	3/4"	(19.0)	1 3/8"	(34.9)	630	(2.83)	71	(32.2)
B351L-7/8	7/8"-9	3"	(76.2)	3 1/4"	(82.5)	1"	(25.4)	1 7/8"	(47.6)	1200	(5.34)	184	(83.4)

B3036L C-Clamp with Locknut

- Safety Factor of 5
- When Retaining Strap is required, order B3363 or B3364 separately
- Setscrew and locknut included
- Material: Malleable iron
- Standard finishes: ZN, PLN

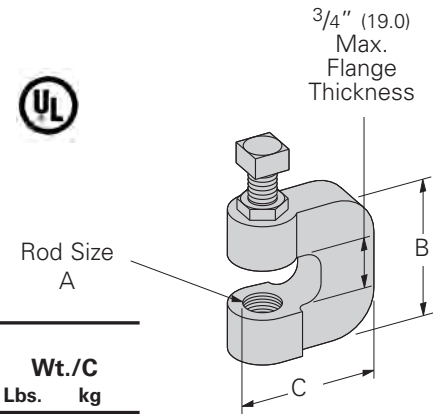

Part Number With Locknut	Rod Size A	B		C		Design Load		Wt./C	
		In.	mm	In.	mm	Lbs.	kN	Lbs.	kg
B3036L-3/8	3/8"-16	1 3/4"	(44.4)	1 3/4"	(44.4)	300	(0.89)	29	(13.1)
B3036L-1/2	1/2"-13	1 3/4"	(44.4)	1 3/4"	(44.4)	380	(1.69)	28	(12.7)
B3036L-5/8	5/8"-11	2"	(50.8)	1 7/8"	(47.6)	530	(2.36)	55	(24.9)
B3036L-3/4	3/4"-10	2"	(50.8)	2"	(50.8)	530	(2.36)	72	(32.6)

B3362 thru B3365 Retaining Strap

- † When ordering specify L (Length) as a suffix to the part number
- Material: 14 Gauge (1.9)
- Standard finishes: GALV, SS4

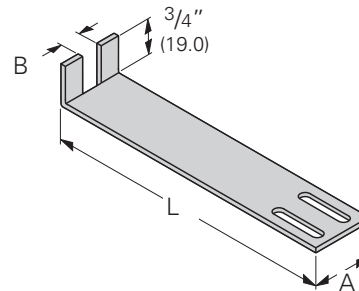

Part No.	Wt./C for Length L of				A	B	For Use With				
	6" (152.4)	8" (203.2)	10" (254.0)	12" (304.8)							
	Lbs.	kg	Lbs.	kg	In.	mm					
B3362†	17	(7.7)	24	(10.9)	31	(14.0)	38	(17.2)	1 1/4" (31.7)	7/16" (11.1)	B351-3/8 & 1/2
B3363†	16	(7.2)	23	(10.4)	30	(13.6)	37	(16.8)	1 1/4" (31.7)	5/8" (15.9)	B351-5/8 & 3/4 B3036-3/8 & 1/2
B3364†	16	(7.2)	23	(10.4)	30	(13.6)	37	(16.8)	1 1/4" (31.7)	1 1/16" (17.4)	B3036-5/8 & 3/4
B3365†	21	(9.5)	29	(13.1)	37	(16.8)	46	(20.8)	1 1/2" (38.1)	3/4" (19.0)	B351-7/8

† See note above.

Reference page 113 for general fitting and standard finish specifications.

Beam Clamps

B3033 Reversible Wise Jaw Wedge C-Clamp (Malleable Iron)

- Safety Factor of 5
- Setscrew and locknut included
- Material: Malleable iron
- Standard finishes: HDG with ZN hardware, PLN



Throat Openings
 1 1/4" (31.7) For
 3/8 & 1/2 Sizes
 1 5/16" (33.3) For
 5/8 & 3/4 Sizes

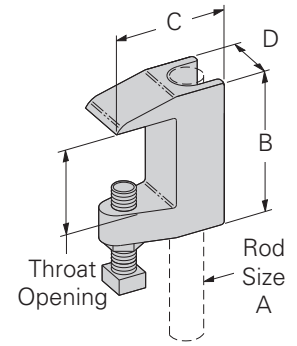

Part No.	Rod Size A	B		C		D		Design Load		Wt./C		UL Max. Pipe Size In. mm	
		In.	mm	In.	mm	In.	mm	Lbs.	kN	Lbs.	kg		
B3033-3/8	3/8"-16	2 1/4"	(57.1)	2"	(50.8)	1 1/8"	(28.6)	500	(2.22)	46	(20.8)	4"	(100)
B3033-1/2	1/2"-13	2 5/16"	(58.7)	2 3/16"	(55.5)	1 1/4"	(31.7)	810	(3.60)	64	(29.0)	8"	(200)
B3033-5/8	5/8"-11	2 5/8"	(66.7)	2 1/2"	(63.5)	1 3/8"	(34.9)	1000	(4.48)	116	(52.6)	8"	(200)
B3033-3/4	3/4"-10	2 11/16"	(68.3)	2 1/2"	(63.5)	1 7/16"	(36.5)	1400	(6.22)	140	(63.5)	10"	(250)

B3034 Wedge C-Clamp

- Safety Factor of 5
- 3/4" (19.0) Max. Flange Thickness
- Setscrew and locknut included
- Material: Malleable iron
- Standard finishes: HDG with ZN hardware, PLN

Note:
 3/8" & 1/2" Sizes
 Are Reversible
 Style



*
 3/8 & 1/2
 Sizes Only

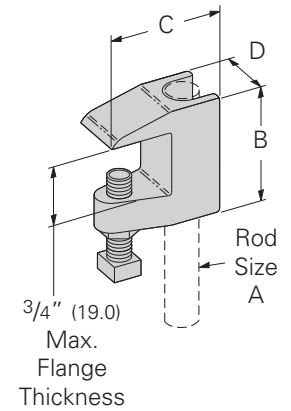

Part No.	Rod Size A	B		C		D		Design Load		Wt./C		UL Max. Pipe Size In. mm	
		In.	mm	In.	mm	In.	mm	Lbs.	kN	Lbs.	kg		
B3034-3/8*	3/8"-16	1 5/8"	(41.3)	2"	(50.8)	7/8"	(22.2)	560	(2.49)	54	(24.5)	4"	(100)
B3034-1/2*	1/2"-13	1 13/16"	(46.0)	2 3/16"	(55.5)	1 3/16"	(30.2)	810	(3.60)	51	(23.1)	8"	(200)
B3034-5/8	5/8"-11	1 3/4"	(44.5)	2 1/8"	(54.0)	1 1/8"	(28.6)	1000	(4.48)	70	(31.7)	-	-
B3034-3/4	3/4"-10	2"	(50.8)	2 1/4"	(57.2)	1 1/8"	(28.6)	1500	(6.67)	98	(44.4)	-	-

Fig. 69 (Formally B-Line B3367) Retaining Strap

- Specify 'L' lengths required
- Minimum recommended return on strap is 1" (25.4)
- Material: Pre-Galvanized Steel
- Standard finishes: GALV

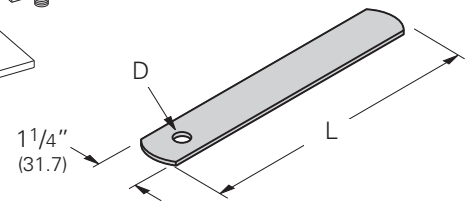
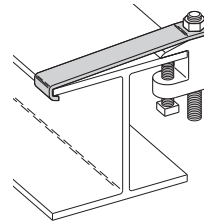

Part No.	Hole Dia. D		For Use	Wt./C** Lbs. kg
	In.	mm		
69-3/8-L	7/16"	(30.1)	B3033-3/8, B3034-3/8 & 65XT-3/8	23.9 (10.8)
69-1/2-L	9/16"	(30.1)	B3033-1/2 & B3034-1/2	23.6 (10.7)
69-5/8-L	11/16"	(50.8)	B3033-5/8	23.2 (10.5)
69-3/4-L	13/16"	(63.5)	B3033-3/4	22.7 (10.3)

** Wt./C based on 6" (152.4) length.
 For each additional inch in strap
 length add 4.2 Lbs (1.9 kg) to Wt./C.

Fig. 69R Retrofit Retaining Strap

- Specify 'L' lengths required
- Minimum recommended return on strap is 1" (25.4)
- Material: Pre-Galvanized Steel
- Standard finishes: GALV

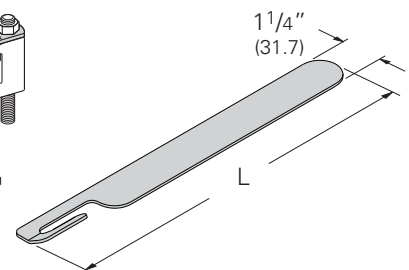
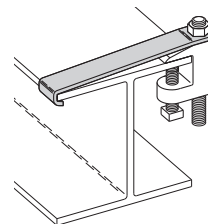

Part No.	Slot Width		For Use	Wt./C** Lbs. kg
	In.	mm		
69R-3/8-L	7/16"	(30.1)	B3033-3/8, B3034-3/8 & 65XT-3/8	22.9 (10.4)
69R-1/2-L	9/16"	(30.1)	B3033-1/2 & B3034-1/2	22.6 (10.2)

** Wt./C based on 6" (152.4) length.
 For each additional inch in strap
 length add 4.2 Lbs (1.9 kg) to Wt./C.

Reference page 113 for general fitting and standard finish specifications.

Fig. 65XT Reversible C-Type Beam Clamp

- Safety Factor of 5
- 3/4" (19.0) Max. Flange Thickness
- Setscrew and locknut included
- Maximum Pipe Size 4" (100)
- Design Load 610 Lbs. (2.71kN)
- Material: Steel
- Standard finishes: ZN, PLN

Rod Size
3/8"-16

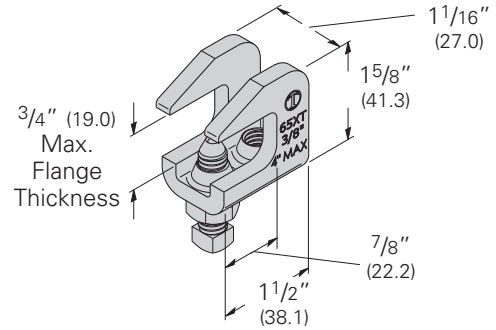

Fig. 65 Reversible Steel C-Type Beam Clamp - 3/4" (19.0mm) Throat Opening

Fig. 66 Reversible Steel C-Type Beam Clamp - 1 1/4" (31.7mm) Throat Opening

- Safety Factor of 5
- Maximum Pipe Size 4" (100) for 3/8"-16 rods
- Maximum Pipe Size 8" (100) for 1/2"-13 rods
- Material: Steel
- Standard finishes: ZN, PLN

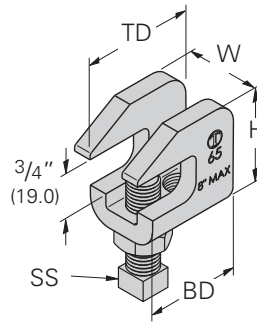

Fig. 65

Setscrews and locknuts included

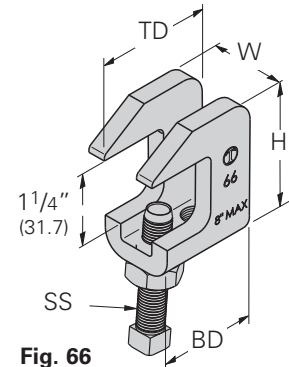

Fig. 66

Part No.	Rod Size	Set Screw SS	TD		BD		H		W		Mac. Rec Load* Lbs. (kN)	Approx. Wt./100 Lbs. (kg)
			in.	(mm)	in.	(mm)	in.	(mm)	in.	(mm)		
65-1/2	1/2"-13	1/2"-13 x 13/4"	1 15/16"	(49.2)	1 5/8"	(41.3)	1 7/8"	(47.6)	1 1/4"	(31.7)	1130 (31.7)	55 (24.9)
65-5/8	5/8"-11	1/2"-13 x 13/4"	1 15/16"	(49.2)	1 5/8"	(41.3)	1 7/8"	(47.6)	1 1/4"	(31.7)	1130 (31.7)	55 (24.9)
66-3/8	3/8"-16	3/8"-16 x 2"	1 1/2"	(38.1)	1 13/32"	(35.7)	2 3/16"	(55.6)	1"	(25.4)	610 (2.71)	28 (12.7)
66-1/2	1/2"-13	1/2"-13 x 2"	2"	(50.8)	1 21/32"	(42.0)	2 7/16"	(61.9)	1 1/4"	(31.7)	1130 (31.7)	55 (24.9)
66-5/8	5/8"-11	1/2"-13 x 13/4"	2"	(50.8)	1 21/32"	(42.0)	2 7/16"	(61.9)	1 1/4"	(31.7)	1130 (31.7)	55 (24.9)

* Maximum loads for clamp with set screw in up or down position.

Fig. 67SS & Fig. 68SS Reversible Stainless Steel C-Type Beam Clamp

- Safety Factor of 5
- Maximum Pipe Size 4" (100) for 3/8"-16 rods
- Maximum Pipe Size 8" (100) for 1/2"-13 rods
- Material: Stainless Steel
- Standard finishes: ZN, PLN

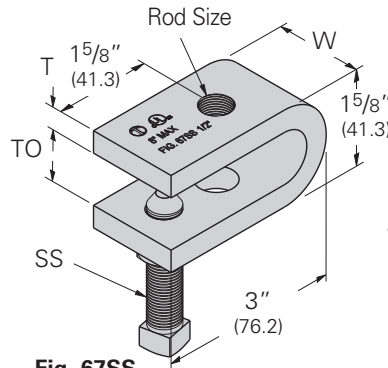

Fig. 67SS

Setscrews and locknuts included

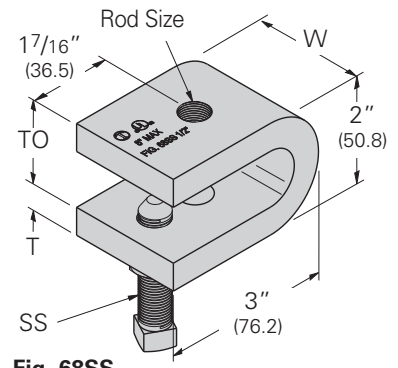

Fig. 68SS

Part No.	Rod Size	Set Screw SS	T		W		TO		Mac. Rec Load* Lbs. (kN)	Approx. Wt./100 Lbs. (kg)
			in.	(mm)	in.	(mm)	in.	(mm)		
67SS-3/8	3/8"-16	3/8"-16 x 1 1/2"	3/8"	(9.6)	1"	(25.4)	7/8"	(22.2)	1500 (6.67)	68 (30.8)
67SS-1/2	1/2"-13	1/2"-13 x 2"	3/8"	(9.6)	1 1/2"	(38.1)	7/8"	(22.2)	4050 (18.0)	107 (48.5)
68SS-3/8	3/8"-16	3/8"-16 x 1 1/2"	3/8"	(9.6)	1 1/2"	(38.1)	1 1/4"	(31.7)	1500 (6.67)	84 (38.1)
68SS-1/2	1/2"-13	1/2"-13 x 2"	1/2"	(12.7)	2"	(50.8)	1"	(25.4)	4050 (18.0)	170 (77.1)

Reference page 113 for general fitting and standard finish specifications.

Beam Clamps

B3037Z Z-Purlin C-Clamp

- Design Load 500 Lbs. (2.22 kN)
- Safety Factor of 5
- Designed for attaching a 3/8"-16 hanger rod to the bottom flange of a Z-purlin
- Setscrew and locknut included
- Material: Malleable iron
- Standard finishes: ZN, PLN

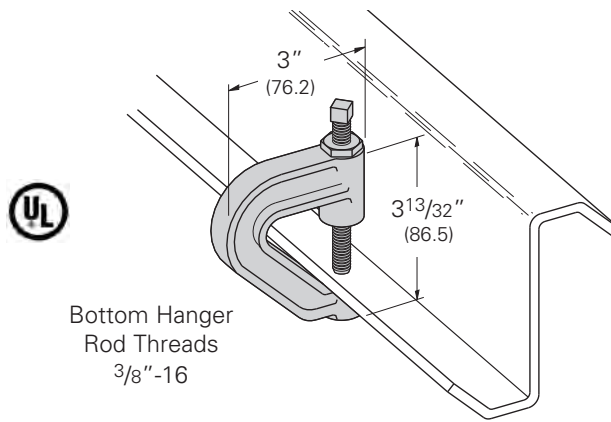

B444 Series Rod Support

- Safety Factor of 5
- Max. Flange Thickness
3/4" (19.0) for 1/4 & 5/16 sizes
1" (25.4) for 3/8 & 1/2 sizes
- Setscrew included
- Material: Malleable iron
- Standard finish: ZN, available in HDG with CZ Hardware

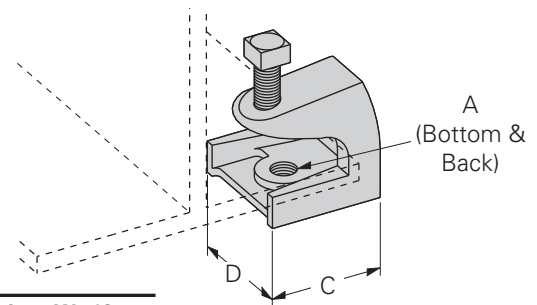

Part No.	Thread Size A	Set Screw	C		D		Design Load		Wt./C	
			In.	mm	In.	mm	Lbs.	kN	Lbs.	kg
B444-1/4	1/4"-20	1/4"-20	1 3/8"	(34.9)	1 3/16"	(30.1)	150	(.66)	24	(10.9)
B444-5/16	5/16"-18	1/4"-20	1 3/8"	(34.9)	1 3/16"	(30.1)	150	(.66)	23	(10.4)
B444-3/8	3/8"-16	1/2"-13	1 7/8"	(47.6)	2"	(50.8)	350	(7.12)	65	(29.5)
B444-1/2	1/2"-13	5/8"-11	2 3/8"	(60.3)	2 1/2"	(63.5)	1000	(4.45)	132	(59.9)

BC442 Light Duty Beam Clamp

- Design Load 75 Lbs. (.33 kN)
- Safety Factor of 5
- 1 1/16" (17.5) Max. Flange Thickness
- Setscrew included
- Holes tapped 1/4"-20 (Bottom & Back)
- Material: 13 Gauge (2.3)
- Standard finish: ZN
- Wt./C 13 Lbs. (3.9 kg)

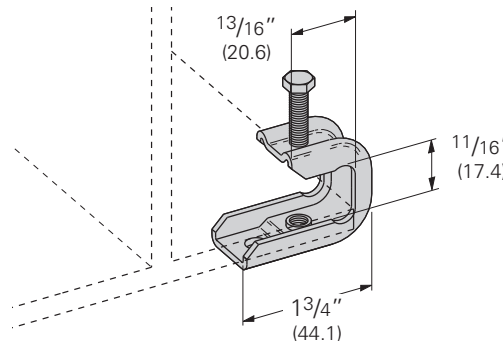

B210 Beam Clamp

- Design Load 800 Lbs. (3.56 kN)
- Safety Factor of 5
- 5/8" (15.9) Max. Flange Thickness
- 1/2"-13 Setscrew included
- Standard finish: ZN
- Wt./C 100 Lbs. (45.3 kg)

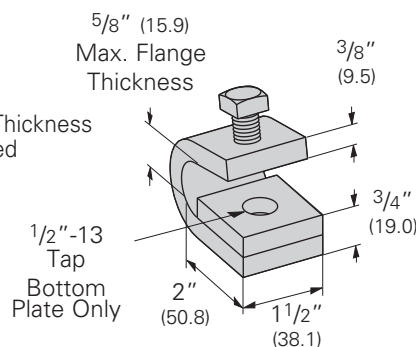

B210A Beam Clamp

- Design Load 300 Lbs. (1.33 kN)
- Safety Factor of 5
- 3/4" (19.0) Max. Flange Thickness
- 3/8"-16 Setscrew included
- Standard finish: ZN
- Wt./C 60 Lbs. (27.2 kg)

